

Single-Axis Robot

5. KA Series

5.1 Features

- ⊙ Lightweight and high rigidity aluminum base
- ⊙ Easy system installation and maintenance
- ⊙ Complete selection of accessories for most applications
- ⊙ Customized design

5.2 Applications

- ⊙ Precision industry
- ⊙ FPD industry
- ⊙ Conveying equipment
- ⊙ Inspection & testing equipment
- ⊙ Assembly equipment



5.3 Model Number of Single-Axis Robot Series

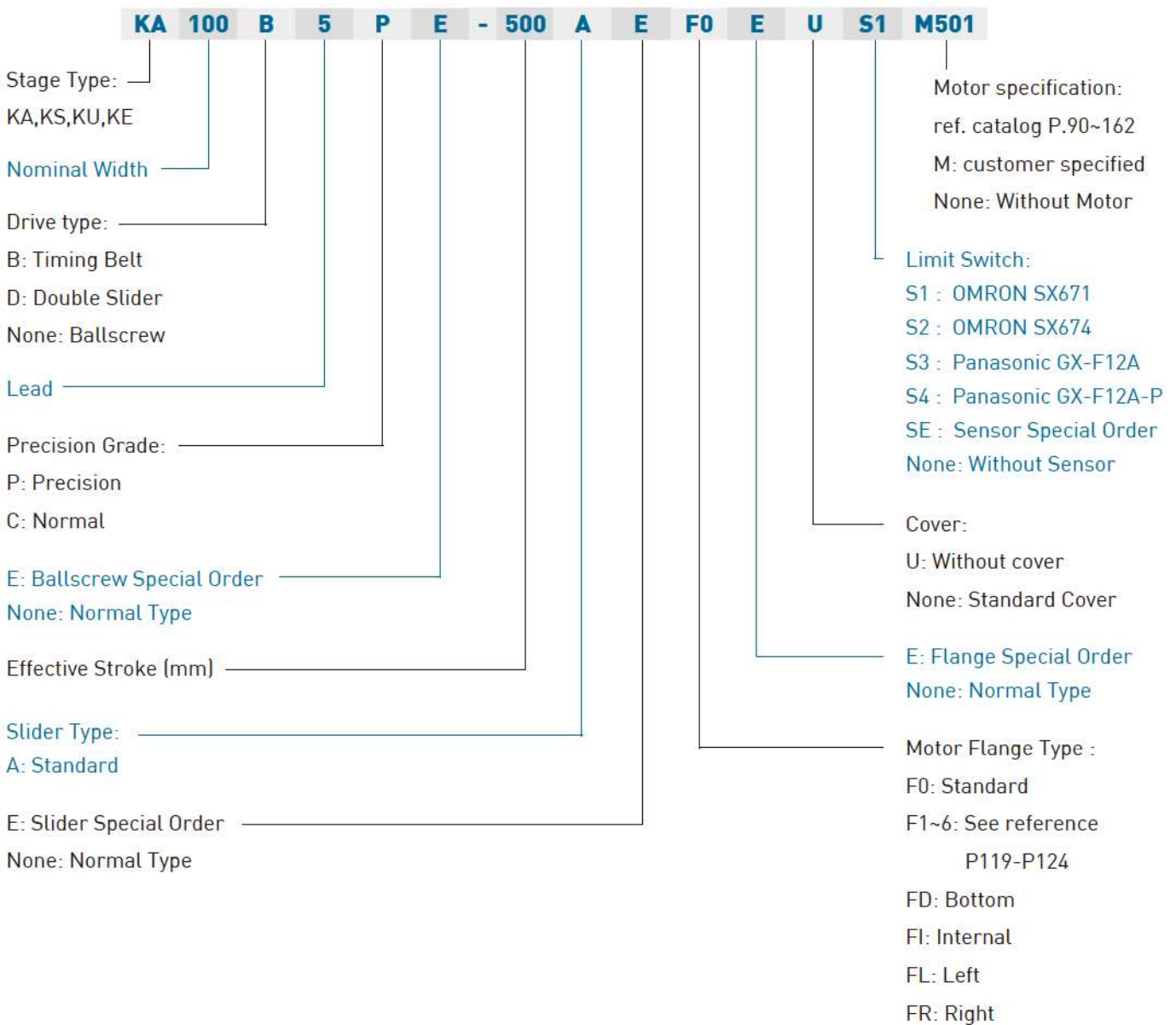

5.4 Specifications

The KA series designation is represented by the following:

(1)	(2)	(3)	(4)	(5)	(6)	(7)	(8)	(9)
Model	Lead	Precision Grade	Effective Stroke	Slider Type	Motor Flange	Aluminum Cover	Limit Switch	Motor

1. Model

KA is the designation for all KA models and the number represents the width of the aluminum base.

2. Lead

The lead on the ballscrew, in millimeters, indicates how far a sliding table will travel with a complete rotation of the ballscrew. The following table shows the current available ballscrews for the KA series :

KA Model	KA136															
	KA100						KA170						KA200			
Ballscrew diameter (Φ)	15			16			20			25			32		25	
Lead (P)	10	20	40	5	10	32	5	10	20	40	25	50	32	40	10	25
L (available in left hand thread)			*	L	L	*	L		L	*	*	*	*	*	*	*

*Please contact HIWIN for high lead screws, left-hand thread screws, or any unlisted ballscrew.

3. Precision Grade

The precision grade for the sliding table to repeat the same position after traveling back and forth.

C; Normal grade : ±0.02mm, P; Precision grade : ±0.01mm.

The repeatability is measured by the largest error occurred at any point when the sliding table is traveling back and forth.

*Attention: KA products do not indicate the absolute positional accuracy.

4. Effective Stroke

The travel range for the KA sliding table (in millimeters).

*Attention: Vibration might occur when the effective stroke is longer than what is listed in the catalog. If vibration occurs, reduce the RPM to help improve the situation. Refer to the “Speed” section for information regarding RPM values.

5. Slider Type

The KA series is designed to only support the listed loading. Please contact HIWIN for inquiries on greater dynamic load or heavy load models.

6. Motor Flange

Direct connection is the standard type on the KA series. There are different flange options for adapting different types of motors, please refer to the following table.

	KA100		KA136		KA170		KA200	
	Screw	PCD	Screw	PCD	Screw	PCD	Screw	PCD
F0	M3	40	M4	60	M5	70	M6	90
	M4	46	M5	70				
F1	M3	45	M4	70	M6	90	M5	70
F2			M4	46	M5	90	M5	90
F3			M3	45	M6	□70		
F4			M5	90	M6	□69.58		
F5			M4	□50				
F6			M4	□47.14				

FD: Bottom connected motor (belt pulley drive).

FI : Internal connected motor (coupling drive).

FL : Left connected motor (belt pulley drive).

FR : Right connected motor (belt pulley drive).

Please refer to the Appendix for different flange sizes.

7. Aluminum Cover

All standard KA models are equipped with an aluminum protective cover. U: without aluminum cover.

8. Limit Switch

HIWIN provides some standard options for limit switches. Please contact a HIWIN sales representative for any other type that is not listed.

9. Motor

Motor specification: ref. catalog P.167

No mark: motor not included. Please inform HIWIN in advance when installing a motor provided by the customer.

M: motor included. Please refer to the Appendix for motor selection, for other customized motors please contact a HIWIN sales representative.

5.5 Product List

Series	Drive Type	Aluminum Base Width	Motor Choice	Maximum Load (kg)*1												Motor Connection Type	Model		
				Lead (mm)															
				1	2	4	5	10	20	25	1	2	4	5	10			20	25
				Horizontal						Vertical									
KA	Ballscrew	90	100W				24	12					6	3			F0, F1	KA90-	
		100					50	32	20					12	8	3		F0, F1, FD, FI, FL, FR	KA100-
		120					50	32	20					12	8	3		F0, F1	KA120-
		136	200W				95	75	40					27	18	7		F0~F6, FD, FI, F, FR	KA136-
		150						80	40						20	8		F0~F6	KA150-
		170	400W					125	75						30	14		F0~F4, FD, FI, FL, FR	KA170-
	200	750W					150		85					40		20	F0~F2, FD, FI, FL, FR	KA200	
	Belt*2	100	100W				7.5											FL, FR	KA100B-
		136	200W				15											FL, FR	KA136B-
170		400W				30											FL, FR	KA170B-	
KS	Ballscrew	90	100W				24	12					6	3			FI, F1	KS90-	
		100					8	6	3.5					2	1.5	1		F1, FI, FL, FR	KS100-
		120					50	32	20						12	8	3		FI, F1
		140	200W					75	35						18	7		FI, FL, FR	KS140
		150						80	40						20	8		FI	KS150-
		180	400W					110	50						30	14		FI, FL, FR	KS180-
	Belt*2	100	100W				3											FL, FR	KS100B-
		140	200W				15											FL, FR	KS140B-
		180	400W				30											FL, FR	KS180B-
KU	Ballscrew	60	100W				30	20						7	5		F0, F1	KU60-	
		80	200W				60	40	20						15	10	5	F0~F6	KU80-
KE	Ballscrew	30	28 stepping drive	3									1				F0	KE30-	
		40	50W		6		4						1.5		1		F0~F2	KE40-	
		50				8								2			F0, F1	KE50-	
		65	100W				15	8							4	2		F0, F1	KE65-
		70					20	15							5	4		F0, F1	KE70-
		90	200W				25	23							6	5		F0~F6	KE90-

*1. Maximum mass refers to the maximum load value the stage could sustain. Load center is just above the sliding table.

2. The belt driven KA is to be used in horizontal applications. Maximum linear velocity of 1800 mm/sec.

5.6 U-shaped aluminum base features a light weight construction and high rigidity

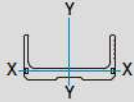
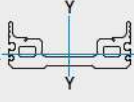
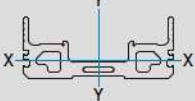
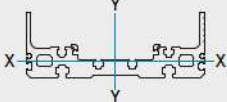
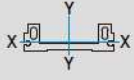
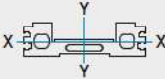
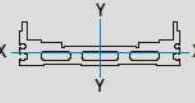
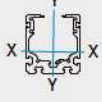
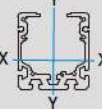
Series	Moment of Inertia (mm ⁴)	I _{xx}	I _{yy}	
KA	KA100	2.17 x10 ⁵	1.81x10 ⁶	
	KA136	3.37x10 ⁵	5.36x10 ⁶	
	KA170	8.84x10 ⁵	1.24x10 ⁷	
	KA200	9.52x10 ⁵	1.90x10 ⁷	
KS	KS100	8.67x10 ⁴	1.45x10 ⁶	
	KS140	2.34x10 ⁵	4.4x10 ⁶	
	KS180	3.7x10 ⁵	1.2x10 ⁷	
KU	KU60	5.24x10 ⁵	5.48x10 ⁵	
	KU80	1.56x10 ⁵	1.67x10 ⁶	

5.7 Table for the operating speed and stroke of KA

	KA Model				KA90		KA100				KA136			KA170		
														KA200		
	Ballscrew D (mm)				12		15		16		20			25		
	Ballscrew dr (mm)				9.642	9.622	12.364	12.399	12.899	12.684	16.924	16.624	17.084	21.824	21.644	22.094
Lead (mm)	5	10	20	25	5	10	10	20	5	10	5	10	20	10	20	25
RPM: S(rpm)	Maximum Linear Velocity V: (mm/sec)				Maximum Stroke											
200	17	33	67	83	2528	2525	2883	2887	2948	2922	-	-	-	-	-	-
300	25	50	100	125	2035	2033	2325	2329	2378	2357	2747	2617	2657	-	-	-
400	33	67	133	167	1742	1740	1993	1996	2039	2020	2358	2232	2266	2594	2582	2611
500	42	83	167	208	1541	1539	1766	1769	1807	1791	2093	1969	1999	2292	2282	2308
600	50	100	200	250	1393	1392	1598	1601	1636	1621	1897	1774	1802	2070	2060	2084
700	58	117	233	292	1278	1277	1468	1471	1503	1489	1744	1623	1649	1897	1888	1910
800	67	133	267	333	1186	1184	1363	1366	1396	1383	1622	1502	1526	1758	1749	1770
900	75	150	300	375	1109	1108	1277	1279	1307	1295	1520	1401	1424	1642	1634	1654
1000	83	167	333	417	1044	1043	1203	1205	1232	1220	1434	1316	1337	1545	1537	1556
1100	92	183	367	458	988	987	1140	1142	1167	1156	1360	1242	1263	1461	1453	1471
1150	96	192	383	479	963	962	1111	1113	1138	1128	1327	1209	1230	1423	1416	1433
1200	100	200	400	500	940	938	1085	1086	1111	1101	1295	1179	1198	1387	1380	1397
1300	108	217	433	542	897	895	1036	1038	1061	1051	1239	1122	1141	1323	1316	1332
1400	117	233	467	583	858	857	993	994	1017	1007	1188	1072	1090	1265	1259	1274
1500	125	250	500	625	824	823	954	955	977	968	1142	1027	1044	1213	1207	1222
1600	133	267	533	667	793	792	918	920	941	932	1101	986	1003	1166	1161	1175
1700	142	283	567	708	764	763	886	888	909	900	1063	949	965	1124	1118	1132
1800	150	300	600	750	739	738	857	858	879	870	1029	915	931	1085	1079	1093
1900	158	317	633	792	715	714	830	831	851	843	997	883	899	1049	1043	1057
2000	167	333	667	833	693	692	805	806	826	817	968	854	870	1016	1010	1024
2100	175	350	700	875	672	671	782	783	802	794	941	827	842	985	980	993
2200	183	367	733	917	653	652	760	762	780	772	916	802	817	956	951	964
2300	192	383	767	958	635	635	740	741	759	752	892	779	793	930	925	937
2400	200	400	800	1000	619	618	721	722	740	733	870	757	771	904	900	912
2500	208	417	833	1042	603	602	704	705	722	715	850	737	750	881	876	888
2600	217	433	867	1083	588	588	687	688	705	698	830	717	731	859	854	866
2700	225	450	900	1125	574	574	671	672	689	682	812	699	712	838	833	845
2800	233	467	933	1167	561	560	656	657	674	667	794	682	695	818	814	825
2900	242	483	967	1208	549	548	642	643	659	652	778	665	678	799	795	806
3000	250	500	1000	1250	537	536	629	630	645	639	762	650	662	781	777	788

* If customer require stroke more than standard specification, please contact HIWIN.

5.8 Dynamic Load

Several factors affect the calculation of loads acting on a KA system as shown in the figure below. The dynamic loads indicated in the catalog (F_y , F_z , M_x , M_y , M_z) are calculated based on 10,000 km of travel distance. To obtain the correct load value and maintain the service life of the KA, each load condition should be carefully considered.

The below figure shows the load being applied onto the center of the KA sliding table. In fact, the load is not necessarily in the middle during its operation, and if the load is not on the center, there could be potential vibrations, over torque, or slow reaction.

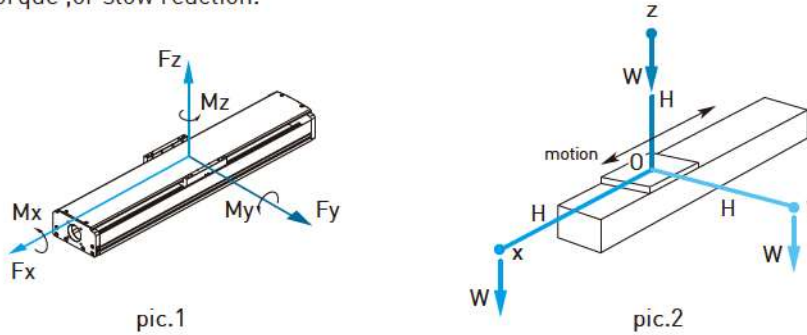

To avoid these circumstances, please keep the loading (W) close to the center of the sliding table (0) within the distance (H).

Off Center Distance	H (mm)		
	x	y	z
KA100	550	550	550
KA136	550	550	550
KA170	780	780	780
KA200	900	900	900

5.9 Installation Method

There are several installation methods for the KA series as shown in the following figures.

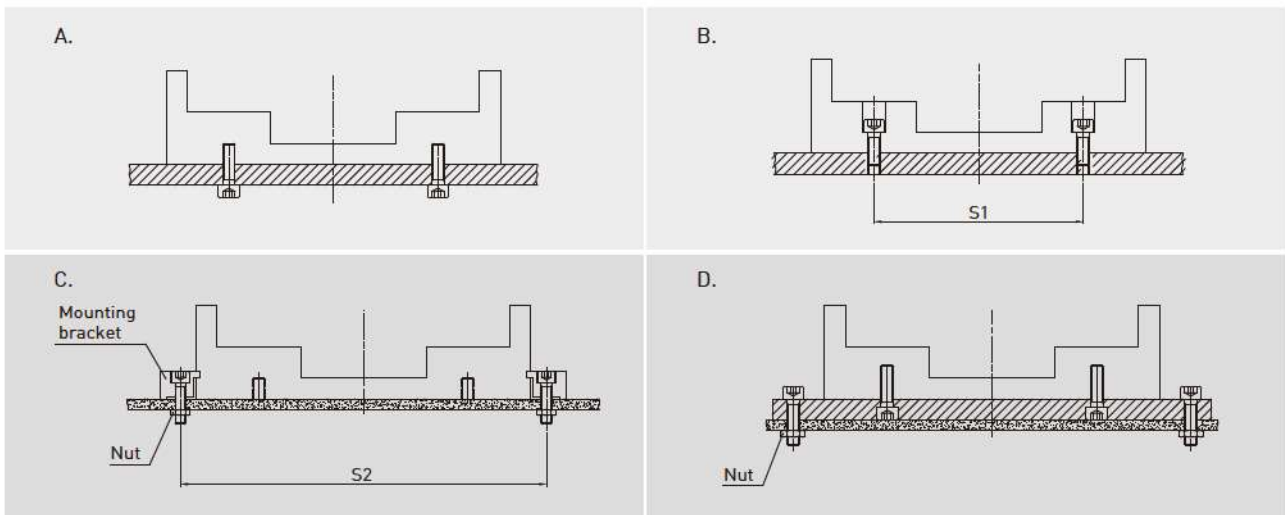

The table below indicates the distance between fixing screws, (S_1) on type B and (S_2) on type C (fixing from above):

KA Model	S1	S2	Screw
KA100	80	116	M5
KA136	112	150	M6
KA170	136	186	M8
KA200	162	218	M8

5.10 Grease Nipple Single Rail / Single Block

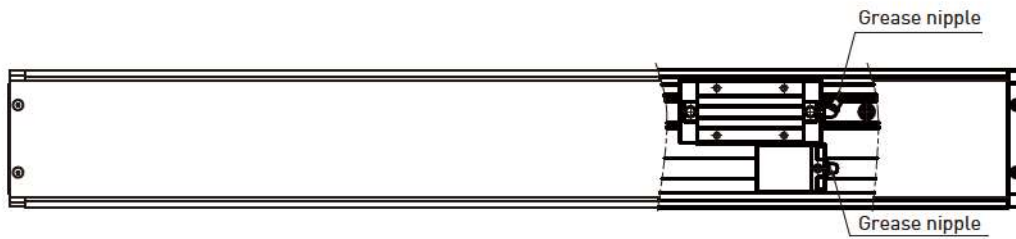

Double Rail / Double Block

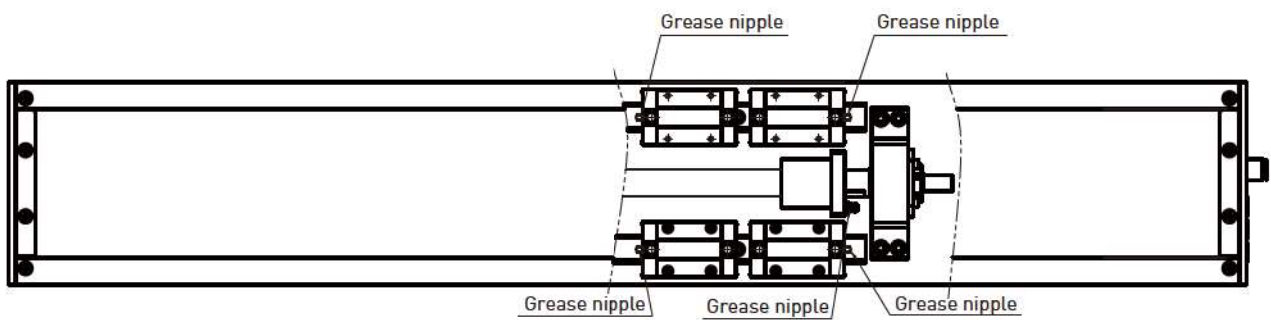

Single Rail / Double Block

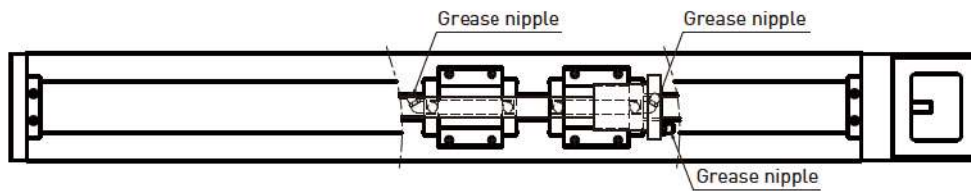

Single Rail / Single Block

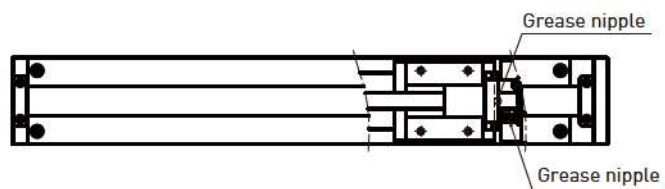

5.11 KA Series

Model Number for KA090

KA090	-10	P	-0600	A	F0	U	S1	M101
Model	Lead	Precision Grade	Effective Stroke	Slider Type	Motor Flange	Cover	Limit Switch	Motor
	5 mm 10 mm	C: Normal P: Precision		A: Standard	F0:Direct	U: Without Cover None : Standard Cover	S1: OMRON SX671 S2: OMRON SX674 S3: Panasonic GX-F12A S4: Panasonic GX-F12A-P None: No Limit Switch	M05□, K05□ M10□, K10□ Motor specification: ref. catalog P.167 M:customer specified None:Without Motor

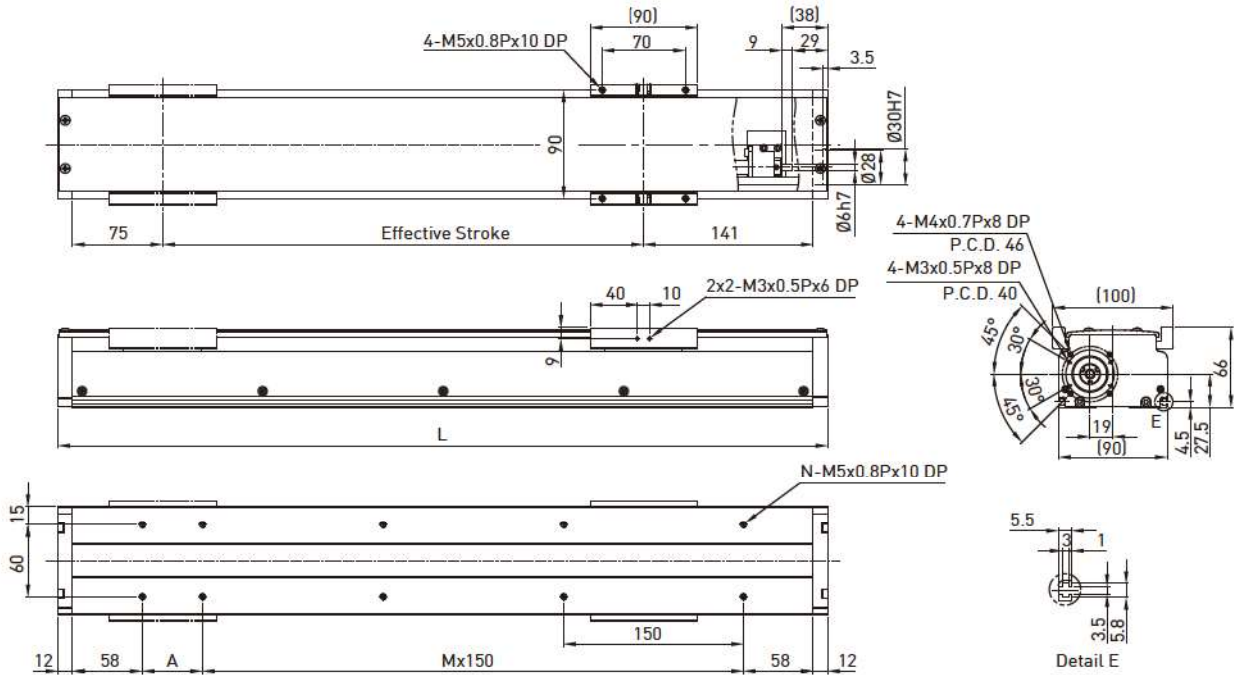

Effective stroke (mm)	L	A	M	N	Weight (kg)	AC motor output		W		
						Drive	W	100	Ballscrew C7(normal)	
50	290	150	0	4	3.38	Lead	mm	5	10	
100	340	50	1	6	3.78	Rated RPM	RPM	3000	3000	
150	390	100	1	6	4.18	Max linear speed*	mm/sec	250	500	
200	440	150	1	6	4.58	Rated thrust	N	280	140	
250	490	50	2	8	4.98	Repeatability	mm	±0.02		
300	540	100	2	8	5.38	Effective stroke	mm	150~600		
350	590	150	2	8	5.78	Max load (H)	kg	24	12	
400	640	50	3	10	6.18	Rated dynamic load**	F _{yd}	N	50	50
450	690	100	3	10	6.58		F _{zd}	N	240	160
500	740	150	3	10	6.98		M _{xd}	N-m	5	4.5
550	790	50	4	12	7.38		M _{yd}	N-m	2.3	2.1
600	840	100	4	12	7.78		M _{zd}	N-m	2.3	2.1
Permitted load condition***						$\frac{F_y}{F_{yd}} + \frac{F_z}{F_{zd}} + \frac{M_x}{M_{xd}} + \frac{M_y}{M_{yd}} + \frac{M_z}{M_{zd}} \leq 1$ F _y , F _z , M _x , M _y , M _z are working loads				

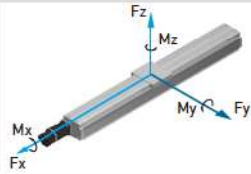

* Vibration might occur when the effective stroke is longer than 550mm. The maximum speed should be decreased by 15% for every 100mm of increased stroke.
 ** The load condition is based on 10,000km operation.
 *** If used on the vertical axis or in a special condition, please contact HIWIN.

Model Number for KA100

KA100	-20	P	-1050	A	F0	U	S1	M101
Model	Lead	Precision Grade	Effective Stroke	Slider Type	Motor Flange	Cover	Limit Switch	Motor
	5 mm 10 mm 20 mm	C: Normal P: Precision		A: Standard	F0:Direct	U: Without Cover None : Standard Cover	S1: OMRON SX671 S2: OMRON SX674 S3: Panasonic GX-F12A S4: Panasonic GX-F12A-P None: No Limit Switch	M05□, K05□ M10□, K10□ Motor specification: ref. catalog P.167 M:customer specified None:Without Motor

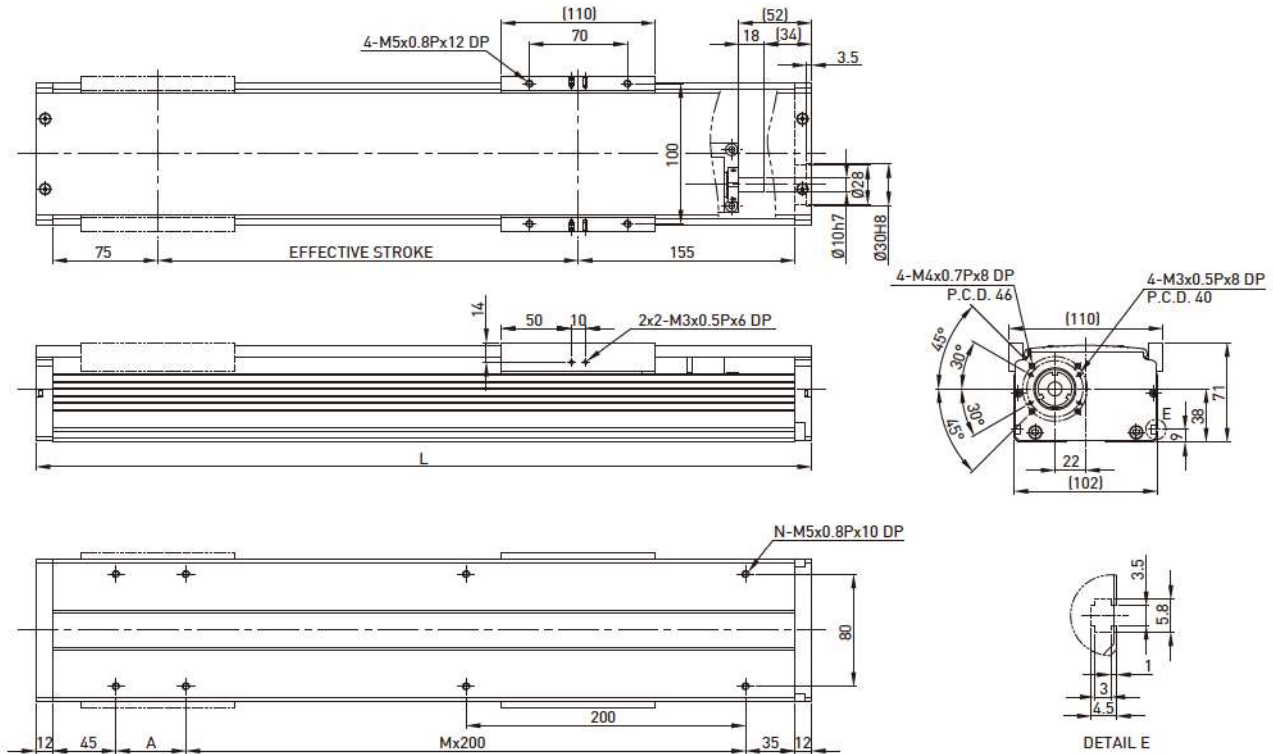

Effective stroke (mm)	L	A	M	N	Weight (kg)	AC motor output	W	100	
100	354	50	1	6	4.86	Drive	Ballscrew C7(normal)		
150	404	100	1	6	5.34	Lead	mm	5 10 20	
200	454	150	1	6	5.81	Rated RPM	RPM	3000 3000 3000	
250	504	200	1	6	6.29	Max linear speed*	mm/sec	250 500 1000	
300	554	50	2	8	6.77	Rated thrust	N	280 140 70	
350	604	100	2	8	7.25	Repeatability	mm	±0.02	
400	654	150	2	8	7.73	Effective stroke	mm	100-1050	
450	704	200	2	8	8.2	Max load (H)	kg	50 32 20	
500	754	50	3	10	8.67		Fyd	N	50 50 50
550	804	100	3	10	9.15		Fzd	N	500 320 200
600	854	150	3	10	9.63		Mxd	N-m	16 16 16
650	904	200	3	10	10.11		Myd	N-m	14 13.5 13
700	954	50	4	12	10.59		Mzd	N-m	14 13.5 13
750	1004	100	4	12	11.06	Rated dynamic load**	$\frac{F_y}{F_{yd}} + \frac{F_z}{F_{zd}} + \frac{M_x}{M_{xd}} + \frac{M_y}{M_{yd}} + \frac{M_z}{M_{zd}} \leq 1$		
800	1054	150	4	12	11.54		Permitted load condition*** Fy, Fz, Mx, My, Mz are working loads		
850	1104	200	4	12	12.02		* Vibration might occur when the effective stroke is longer than 650mm. The maximum speed should be decreased by 15% for every 100mm of increased stroke.		
900	1154	50	5	14	12.49		** The load condition is based on 10,000km operation.		
950	1204	100	5	14	12.97		*** If used on the vertical axis or in a special condition, please contact HIWIN.		
1000	1254	150	5	14	13.45				
1050	1304	200	5	14	13.93				

Model Number for KA100-FD

KA100	-20	P	-1050	A	FD	U	S1	M101
Model	Lead	Precision Grade	Effective Stroke	Slider Type	Motor Flange	Cover	Limit Switch	Motor
	5 mm 10 mm 20 mm	C: Normal P: Precision		A: Standard	FD: Bottom	U: Without Cover None : Standard Cover	S1: OMRON SX671 S2: OMRON SX674 S3: Panasonic GX-F12A S4: Panasonic GX-F12A-P None: No Limit Switch	M05□, K05□ M10□, K10□ Motor specification: ref. catalog P.167 M:customer specified None:Without Motor

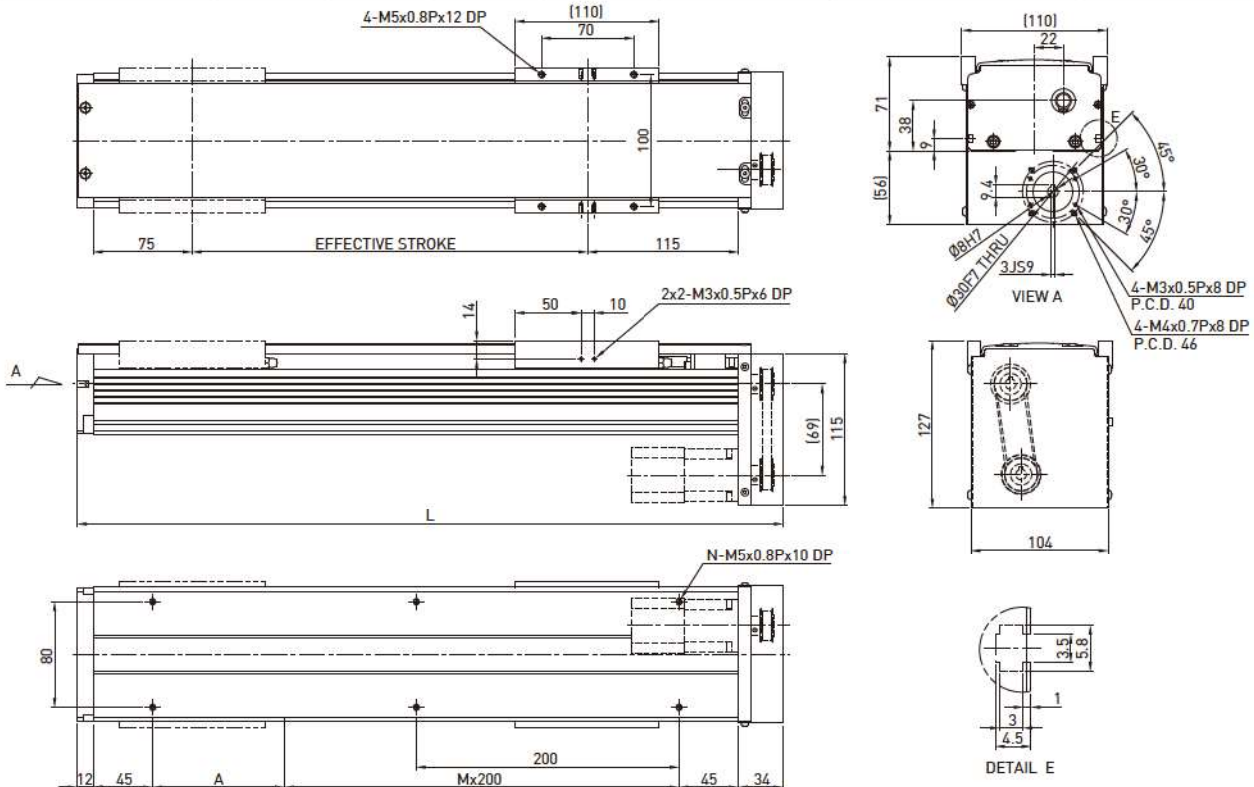

Effective stroke (mm)	L	A	M	N	Weight (kg)	AC motor output				
						W	100			
							Ballscrew C7(normal)			
100	336	200	0	4	4.91	mm	5	10	20	
150	386	50	1	6	5.41	RPM	3000	3000	3000	
200	436	100	1	6	5.88	mm/sec	250	500	1000	
250	486	150	1	6	6.36	N	280	140	70	
300	536	200	1	6	6.85	mm	±0.02			
350	586	50	2	8	7.33	mm	100-1050			
400	636	100	2	8	7.82	kg	50	32	20	
450	686	150	2	8	8.29	F _{yd}	N	50	50	50
500	736	200	2	8	8.76	F _{zd}	N	500	320	200
550	786	50	3	10	9.25	M _{xd}	N-m	16	16	16
600	836	100	3	10	9.73	M _{yd}	N-m	14	13.5	13
650	886	150	3	10	10.22	M _{zd}	N-m	14	13.5	13
700	936	200	3	10	10.71					
750	986	50	4	12	11.19					
800	1036	100	4	12	11.67					
850	1086	150	4	12	12.15					
900	1136	200	4	12	12.63					
950	1186	50	5	14	13.12	$\frac{F_y}{F_{yd}} + \frac{F_z}{F_{zd}} + \frac{M_x}{M_{xd}} + \frac{M_y}{M_{yd}} + \frac{M_z}{M_{zd}} \leq 1$				
1000	1236	100	5	14	13.6	F _y , F _z , M _x , M _y , M _z are working loads				
1050	1286	150	5	14	14.08	* Vibration might occur when the effective stroke is longer than 650mm. The maximum speed should be decreased by 15% for every 100mm of increased stroke. ** The load condition is based on 10,000km operation. *** If used on the vertical axis or in a special condition, please contact HIWIN.				

Model Number for KA100-FI

KA100	-20	P	-1050	A	FI	U	S1	M101
Model	Lead	Precision Grade	Effective Stroke	Slider Type	Motor Flange	Cover	Limit Switch	Motor
	5 mm 10 mm 20 mm	C: Normal P: Precision		A: Standard	FI : Internal	U: Without Cover None : Standard Cover	S1: OMRON SX671 S2: OMRON SX674 S3: Panasonic GX-F12A S4: Panasonic GX-F12A-P None: No Limit Switch	M05□, K05□ M10□, K10□ Motor specification: ref. catalog P.167 M: customer specified None: Without Motor

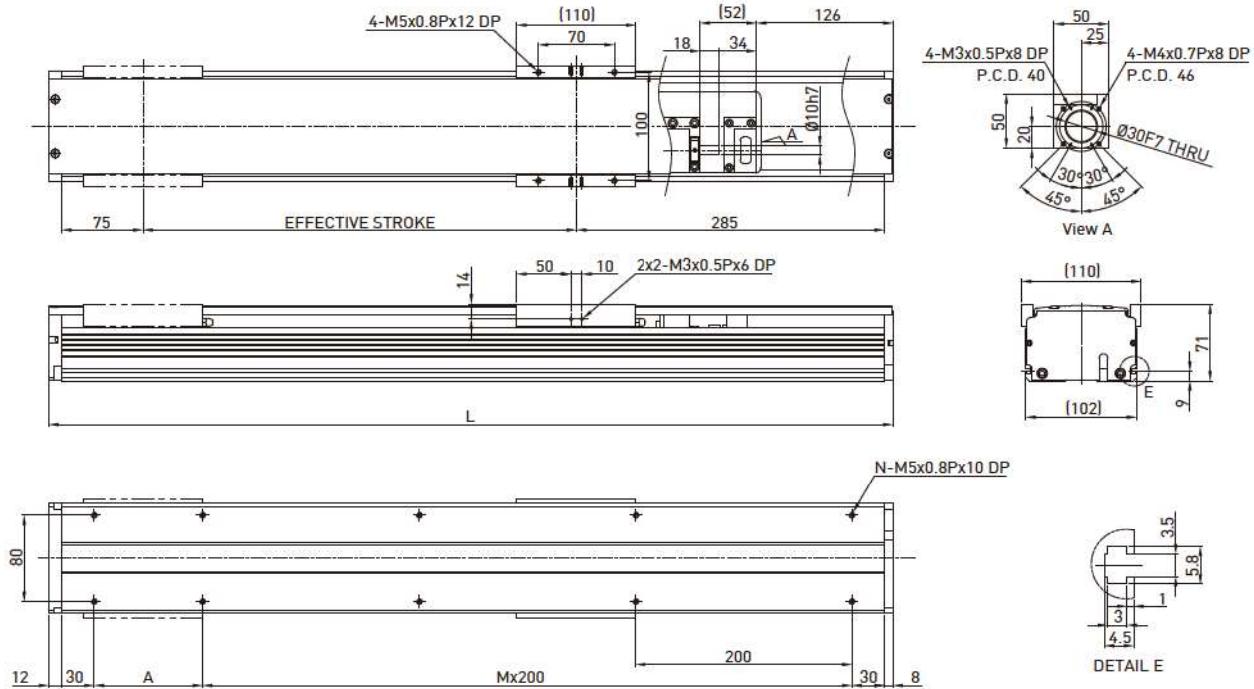

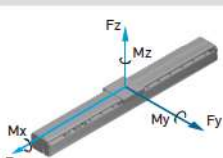
Effective stroke (mm)	L	A	M	N	Weight (kg)	AC motor output Drive	W	100	
100	480	200	1	6	5.2	Lead	mm	5 10 20	
150	530	50	2	8	5.71	Rated RPM	RPM	3000 3000 3000	
200	580	100	2	8	6.22	Max linear speed*	mm/sec	250 500 1000	
250	630	150	2	8	6.73	Rated thrust	N	280 140 70	
300	680	200	2	8	7.24	Repeatability	mm	±0.02	
350	730	50	3	10	7.76	Effective stroke	mm	100-1050	
400	780	100	3	10	8.27	Max load (H)	kg	50 32 20	
450	830	150	3	10	8.77	Rated dynamic load** 	Fyd	N	50 50 50
500	880	200	3	10	9.28		Fzd	N	500 320 200
550	930	50	4	12	9.79		Mxd	N-m	16 16 16
600	980	100	4	12	10.31		Myd	N-m	14 13.5 13
650	1030	150	4	12	10.82		Mzd	N-m	14 13.5 13
700	1080	200	4	12	11.33	Permitted load condition*** $\frac{F_y}{F_{yd}} + \frac{F_z}{F_{zd}} + \frac{M_x}{M_{xd}} + \frac{M_y}{M_{yd}} + \frac{M_z}{M_{zd}} \leq 1$ Fy, Fz, Mx, My, Mz are working loads			
750	1130	50	5	14	11.83				
800	1180	100	5	14	12.35				
850	1230	150	5	14	12.86				
900	1280	200	5	14	13.37				
950	1330	50	6	16	13.88				
1000	1380	100	6	16	14.39				
1050	1430	150	6	16	14.91				

* Vibration might occur when the effective stroke is longer than 650mm. The maximum speed should be decreased by 15% for every 100mm of increased stroke.
 ** The load condition is based on 10,000km operation.
 *** If used on the vertical axis or in a special condition, please contact HIWIN.

Model Number for KA100-FL

KA100	-20	P	-1050	A	FL	U	S1	M101
Model	Lead	Precision Grade	Effective Stroke	Slider Type	Motor Flange	Cover	Limit Switch	Motor
	5 mm 10 mm 20 mm	C: Normal P: Precision		A: Standard	FL: Left	U: Without Cover None : Standard Cover	S1: OMRON SX671 S2: OMRON SX674 S3: Panasonic GX-F12A S4: Panasonic GX-F12A-P None: No Limit Switch	M05□, K05□ M10□, K10□ Motor specification: ref. catalof P.167 M:customer specified None:Without Motor

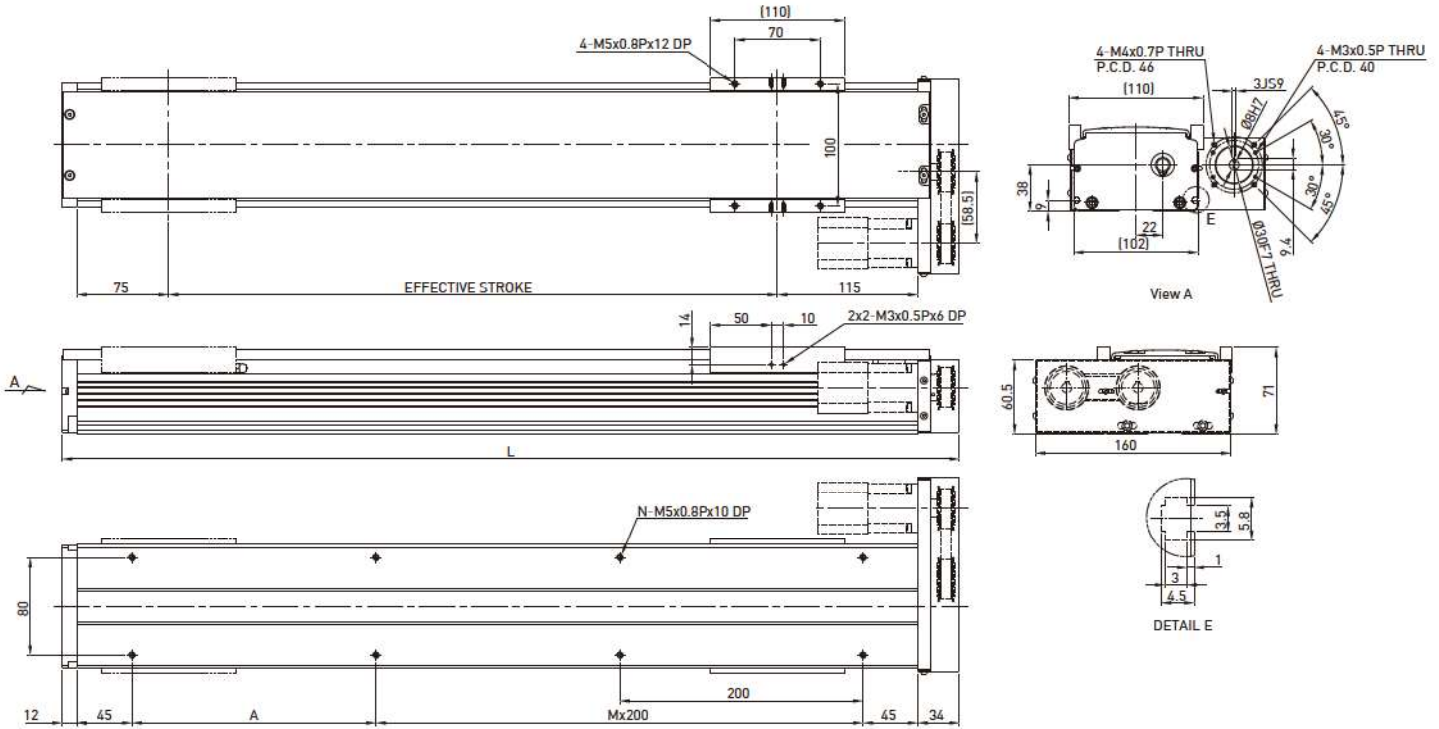

Effective stroke (mm)	L	A	M	N	Weight (kg)	AC motor output	W	100
100	336	200	0	4	4.91	Drive	Ballscrew C7(normal)	
150	386	50	1	6	5.41	Lead	mm	5 10 20
200	436	100	1	6	5.88	Rated RPM	RPM	3000 3000 3000
250	486	150	1	6	6.36	Max linear speed*	mm/sec	250 500 1000
300	536	200	1	6	6.85	Rated thrust	N	280 140 70
350	586	50	2	8	7.33	Repeatability	mm	±0.02
400	636	100	2	8	7.82	Effective stroke	mm	100-1050
450	686	150	2	8	8.29	Max load (H)	kg	50 32 20
500	736	200	2	8	8.76		Fyd	N 50 50 50
550	786	50	3	10	9.25		Fzd	N 500 320 200
600	836	100	3	10	9.73		Mxd	N-m 16 16 16
650	886	150	3	10	10.22		Myd	N-m 14 13.5 13
700	936	200	3	10	10.71		Mzd	N-m 14 13.5 13
750	986	50	4	12	11.19	Rated dynamic load**	$\frac{F_y}{F_{yd}} + \frac{F_z}{F_{zd}} + \frac{M_x}{M_{xd}} + \frac{M_y}{M_{yd}} + \frac{M_z}{M_{zd}} \leq 1$	
800	1036	100	4	12	11.67		Permitted load condition*** Fy, Fz, Mx, My, Mz are working loads	
850	1086	150	4	12	12.15			
900	1136	200	4	12	12.63			
950	1186	50	5	14	13.12			
1000	1236	100	5	14	13.6			
1050	1286	150	5	14	14.08			

* Vibration might occur when the effective stroke is longer than 650mm.
 The maximum speed should be decreased by 15% for every 100mm of increased stroke.
 ** The load condition is based on 10,000km operation.
 *** If used on the vertical axis or in a special condition, please contact HIWIN.

Model Number for KA100-FR

KA100	-20	P	-1050	A	FR	U	S1	M101
Model	Lead	Precision Grade	Effective Stroke	Slider Type	Motor Flange	Cover	Limit Switch	Motor
	5 mm 10 mm 20 mm	C: Normal P: Precision		A: Standard	FR: Right	U: Without Cover None : Standard Cover	S1: OMRON SX671 S2: OMRON SX674 S3: Panasonic GX-F12A S4: Panasonic GX-F12A-P None: No Limit Switch	M05□, K05□ M10□, K10□ Motor specification: ref. catalog P.167 M: customer specified None: Without Motor

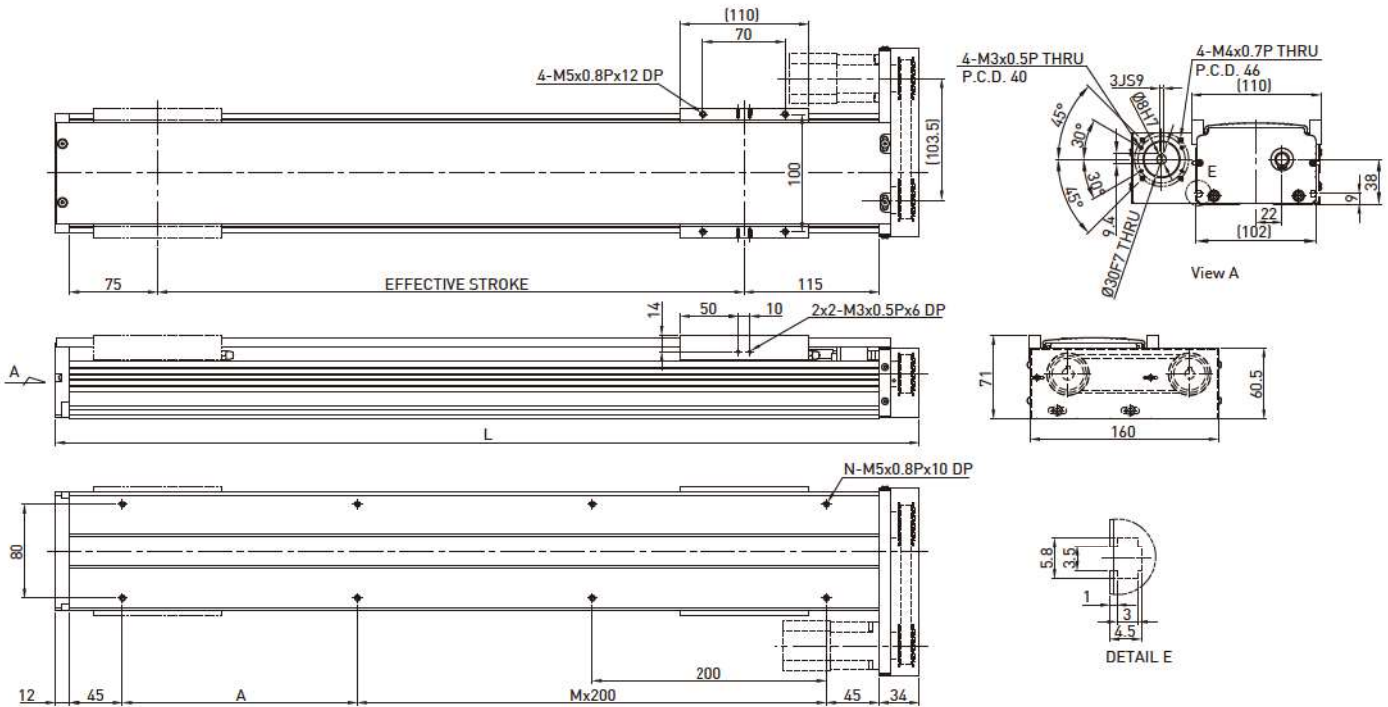

Effective stroke (mm)	L	A	M	N	Weight (kg)	AC motor output					
						W	100				
						Drive	Ballscrew C7(normal)				
						Lead	mm	5	10	20	
						Rated RPM	RPM	3000	3000	3000	
						Max linear speed*	mm/sec	250	500	1000	
						Rated thrust	N	280	140	70	
						Repeatability	mm	±0.02			
						Effective stroke	mm	100-1050			
						Max load (H)	kg	50	32	20	
						Rated dynamic load**	F _{yd}	N	50	50	50
							F _{zd}	N	500	320	200
							M _{xd}	N-m	16	16	16
							M _{yd}	N-m	14	13.5	13
							M _{zd}	N-m	14	13.5	13
						Permitted load condition***	$\frac{F_y}{F_{yd}} + \frac{F_z}{F_{zd}} + \frac{M_x}{M_{xd}} + \frac{M_y}{M_{yd}} + \frac{M_z}{M_{zd}} \leq 1$				
							F _y , F _z , M _x , M _y , M _z are working loads				
						* Vibration might occur when the effective stroke is longer than 650mm.					
						The maximum speed should be decreased by 15% for every 100mm of increased stroke.					
						** The load condition is based on 10,000km operation.					
						*** If used on the vertical axis or in a special condition, please contact HIWIN.					
100	336	200	0	4	4.91						
150	386	50	1	6	5.41						
200	436	100	1	6	5.88						
250	486	150	1	6	6.36						
300	536	200	1	6	6.85						
350	586	50	2	8	7.33						
400	636	100	2	8	7.82						
450	686	150	2	8	8.29						
500	736	200	2	8	8.76						
550	786	50	3	10	9.25						
600	836	100	3	10	9.73						
650	886	150	3	10	10.22						
700	936	200	3	10	10.71						
750	986	50	4	12	11.19						
800	1036	100	4	12	11.67						
850	1086	150	4	12	12.15						
900	1136	200	4	12	12.63						
950	1186	50	5	14	13.12						
1000	1236	100	5	14	13.6						
1050	1286	150	5	14	14.08						

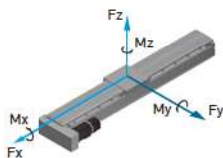

Model Number for KA100B-FL

KA100	B	-84	C	-3000	A	FL	U	S1	M101
Model	Timing Belt	Pulley Perimeter	Precision Grade	Effective Stroke	Slider Type	Motor Flange	Cover	Limit Switch	Motor
			C: Normal		A: Standard	FL: Left	U: Without Cover None : Standard Cover	S1: OMRON SX671 S2: OMRON SX674 S3: Panasonic GX-F12A S4: Panasonic GX-F12A-P None: No Limit Switch	M05□, K05□ M10□, K10□ Motor specification: ref. catalog P.167 M: customer specified None: Without Motor

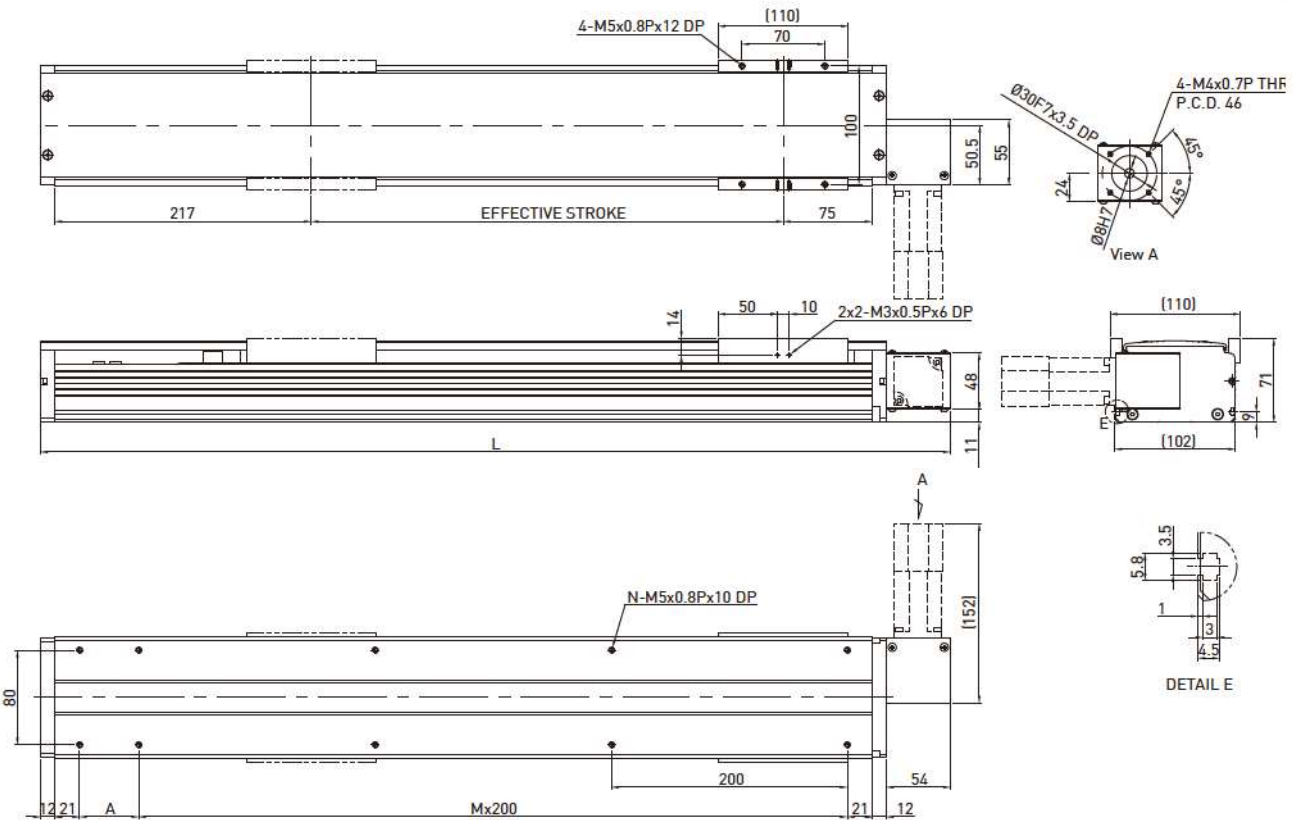

Effective stroke (mm)	L	A	M	N	Weight (kg)	AC motor output Drive	W	100	
200	570	50	2	8	5.41	Pulley Perimeter	mm	84	
400	770	50	3	10	7.07	Pulley RPM	RPM	1286	
600	970	50	4	12	8.83	Max linear speed	mm/sec	1800	
800	1170	50	5	14	10.49	Rated thrust	N	33	
1000	1370	50	6	16	12.15	Repeatability	mm	±0.1	
1200	1570	50	7	18	13.91	Effective stroke	mm	200-3000	
1400	1770	50	8	20	15.57	Max load (H)	kg	7.5	
1600	1970	50	9	22	17.33		F _{yd}	N	50
1800	2170	50	10	24	18.99		F _{zd}	N	75
2000	2370	50	11	26	20.65		M _{xd}	N-m	15
2200	2570	50	12	28	22.41		M _{yd}	N-m	13
2400	2770	50	13	30	24.07		M _{zd}	N-m	13
2600	2970	50	14	32	25.83	Permitted load condition** $\frac{F_y}{F_{yd}} + \frac{F_z}{F_{zd}} + \frac{M_x}{M_{xd}} + \frac{M_y}{M_{yd}} + \frac{M_z}{M_{zd}} \leq 1$ F _y , F _z , M _x , M _y , M _z are working loads			
2800	3170	50	15	34	27.49				
3000	3370	50	16	36	29.15				

*The load condition is based on 10,000km operation.

**For horizontal applications only. If used in a special condition, please contact HIWIN.

Model Number for KA100B-FR

KA100	B	-84	C	-3000	A	FR	U	S1	M101
Model	Timing Belt	Pulley Perimeter	Precision Grade	Effective Stroke	Slider Type	Motor Flange	Cover	Limit Switch	Motor
			C: Normal		A: Standard	FR: Right	U: Without Cover None : Standard Cover	S1: OMRON SX671 S2: OMRON SX674 S3: Panasonic GX-F12A S4: Panasonic GX-F12A-P None: No Limit Switch	M05□, K05□ M10□, K10□ Motor specification: ref. catalof P.167 M:customer specified None:Without Motor

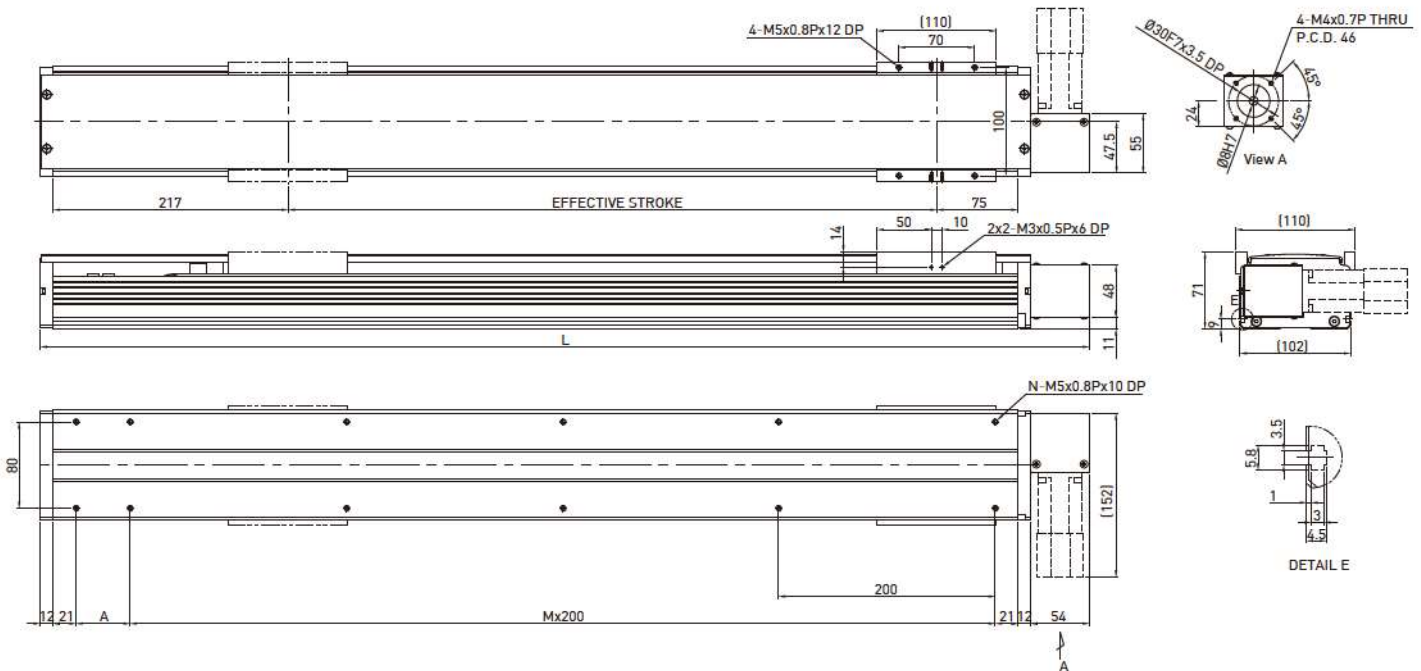

Effective stroke (mm)	L	A	M	N	Weight (kg)	AC motor output Drive	W	100			
200	570	50	2	8	5.41	Pulley Perimeter	mm	84			
400	770	50	3	10	7.07	Pulley RPM	RPM	1286			
600	970	50	4	12	8.83	Max linear speed	mm/sec	1800			
800	1170	50	5	14	10.49	Rated thrust	N	33			
1000	1370	50	6	16	12.15	Repeatability	mm	±0.1			
1200	1570	50	7	18	13.91	Effective stroke	mm	200~3000			
1400	1770	50	8	20	15.57	Max load (H)	kg	7.5			
1600	1970	50	9	22	17.33	Rated dynamic load*	F _{yd}	N	50		
1800	2170	50	10	24	18.99		F _{zd}	N	75		
2000	2370	50	11	26	20.65		M _{xd}	N-m	15		
2200	2570	50	12	28	22.41		M _{yd}	N-m	13		
2400	2770	50	13	30	24.07		M _{zd}	N-m	13		
2600	2970	50	14	32	25.83		$\frac{F_y}{F_{yd}} + \frac{F_z}{F_{zd}} + \frac{M_x}{M_{xd}} + \frac{M_y}{M_{yd}} + \frac{M_z}{M_{zd}} \leq 1$ F _y , F _z , M _x , M _y , M _z are working loads				
2800	3170	50	15	34	27.49						
3000	3370	50	16	36	29.15						
						Permitted load condition**					

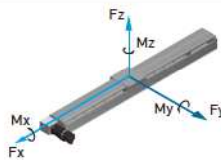

*The load condition is based on 10,000km operation.

**For horizontal applications only. If used in a special condition, please contact HIWIN.

Model Number for KA120

KA120	-20	P	-1050	A	F0	U	S1	M101
Model	Lead	Precision Grade	Effective Stroke	Slider Type	Motor Flange	Cover	Limit Switch	Motor
	5 mm 10 mm 20 mm	C: Normal P: Precision		A: Standard	F0: Direct	U: Without Cover None: Standard Cover	S1: OMRON SX671 S2: OMRON SX674 S3: Panasonic GX-F12A S4: Panasonic GX-F12A-P None: No Limit Switch	M05□, K05□ M10□, K10□ Motor specification: ref. catalog P.167 M: customer specified None: Without Motor

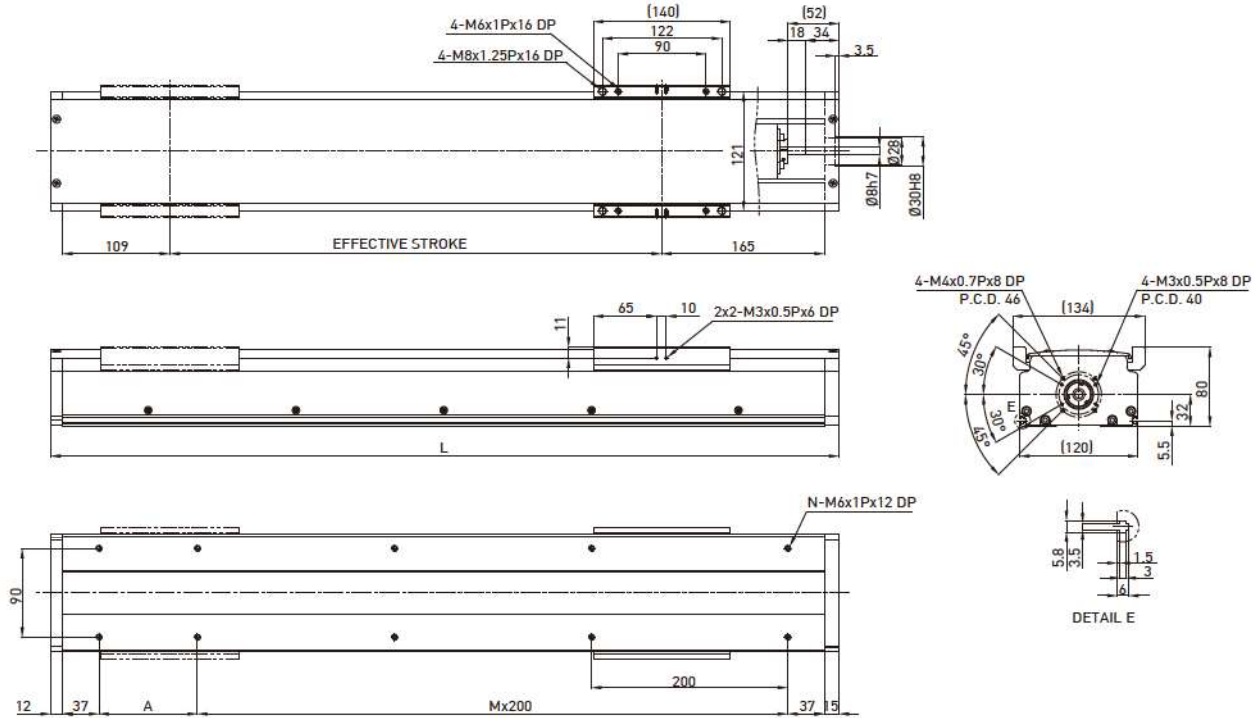

Effective stroke (mm)	L	A	M	N	Weight (kg)	AC motor output			W		
						Drive	Lead	Rated RPM	mm	100	
100	401	100	1	6	7.5		mm	5	10	20	Ballscrew C7(normal)
150	451	150	1	6	8.13		RPM	3000	3000	3000	
200	501	200	1	6	8.76		mm/sec	250	500	1000	
250	551	50	2	8	9.39		N	560	280	140	
300	601	100	2	8	10.02		mm	±0.02			
350	651	150	2	8	10.65		mm	100-1050			
400	701	200	2	8	11.28		kg	50	32	20	
450	751	50	3	10	11.91		N	50	50	50	
500	801	100	3	10	12.54		N	500	320	200	
550	851	150	3	10	13.17		N-m	25	27	28	
600	901	200	3	10	13.8		N-m	20	22	23	
650	951	50	4	12	14.43		N-m	20	22	23	
700	1001	100	4	12	15.06		N-m	20	22	23	
750	1051	150	4	12	15.69	$\frac{F_y}{F_{yd}} + \frac{F_z}{F_{zd}} + \frac{M_x}{M_{xd}} + \frac{M_y}{M_{yd}} + \frac{M_z}{M_{zd}} \leq 1$ <p>Fy, Fz, Mx, My, Mz are working loads</p>					
800	1101	200	4	12	16.32						
850	1151	50	5	14	16.95						
900	1201	100	5	14	17.58						
950	1251	150	5	14	18.21						
1000	1301	200	5	14	18.84						
1050	1351	50	6	16	19.47						

* Vibration might occur when the effective stroke is longer than 650mm.
 The maximum speed should be decreased by 15% for every 100mm of increased stroke.
 ** The load condition is based on 10,000km operation.
 *** If used on the vertical axis or in a special condition, please contact HIWIN.

Model Number for KA136

KA136	-20	P	-1050	A	F0	U	S1	M201
Model	Lead	Precision Grade	Effective Stroke	Slider Type	Motor Flange	Cover	Limit Switch	Motor
	5 mm 10 mm 20 mm	C: Normal P: Precision		A: Standard	F0 : Direct	U: Without Cover None : Standard Cover	S1: OMRON SX671 S2: OMRON SX674 S3: Panasonic GX-F12A S4: Panasonic GX-F12A-P None: No Limit Switch	M20□, K20□ M40□, K40□ Motor specification: ref. catalog P.167 M: customer specified None: Without Motor

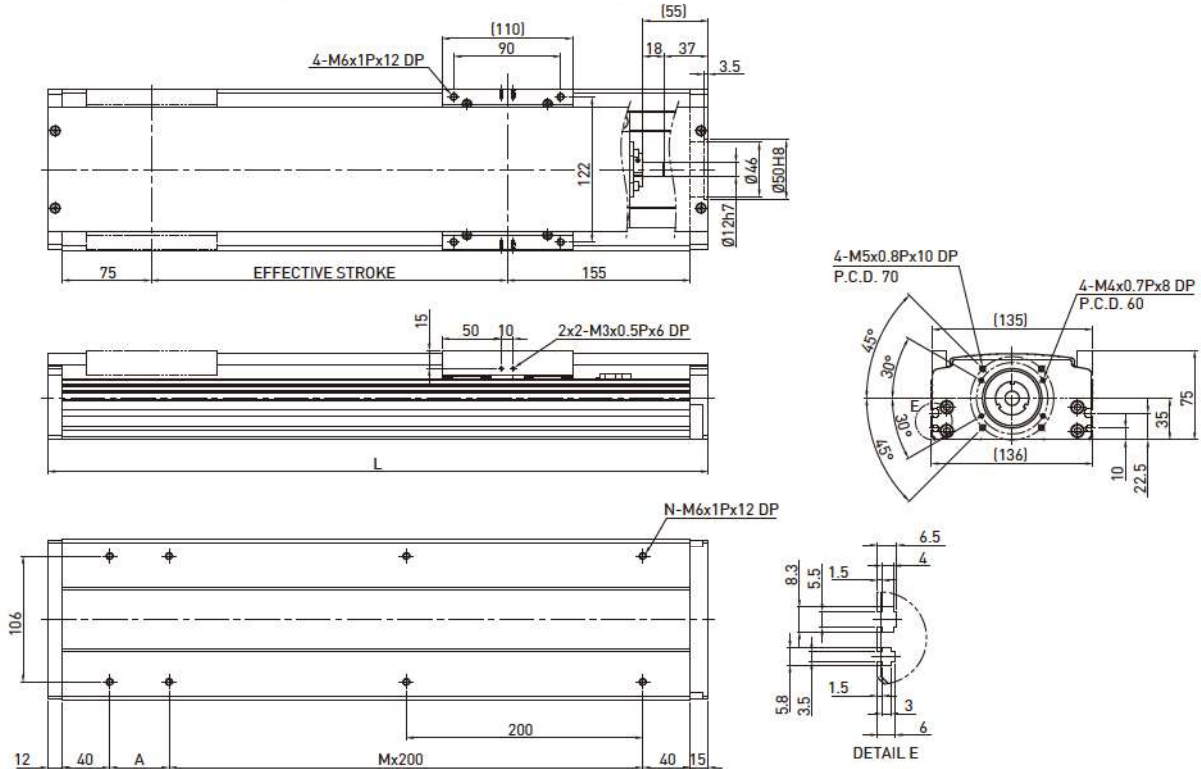

Effective stroke (mm)	L	A	M	N	Weight (kg)	AC motor output			W				
						Drive	Lead	Rated RPM	mm	N	kg	F _{yd}	F _{zd}
100	357	50	1	6	6.19		5	3000	5	50	21	17	17
150	407	100	1	6	6.74		10	3000	10	50	21	17	17
200	457	150	1	6	7.29		20	3000	20	50	21	17	17
250	507	200	1	6	7.84					50	21	17	17
300	557	50	2	8	8.39					280	21	17	17
350	607	100	2	8	8.94					140	21	17	17
400	657	150	2	8	9.49					±0.02	17	17	17
450	707	200	2	8	10.05					100-1050	17	17	17
500	757	50	3	10	10.6					95	17	17	17
550	807	100	3	10	11.15					75	17	17	17
600	857	150	3	10	11.7					40	17	17	17
650	907	200	3	10	12.25					50	17	17	17
700	957	50	4	12	12.8					50	17	17	17
750	1007	100	4	12	13.35					50	17	17	17
800	1057	150	4	12	13.9					50	17	17	17
850	1107	200	4	12	14.45					50	17	17	17
900	1157	50	5	14	15					50	17	17	17
950	1207	100	5	14	15.55					50	17	17	17
1000	1257	150	5	14	16.1					50	17	17	17
1050	1307	200	5	14	16.65					50	17	17	17

Rated dynamic load**

Permitted load condition***

F _{yd}	N	50	50	50
F _{zd}	N	950	750	400
M _{xd}	N-m	21	21	26
M _{yd}	N-m	17	17	21
M _{zd}	N-m	17	17	21

$\frac{F_y}{F_{yd}} + \frac{F_z}{F_{zd}} + \frac{M_x}{M_{xd}} + \frac{M_y}{M_{yd}} + \frac{M_z}{M_{zd}} \leq 1$

F_y, F_z, M_x, M_y, M_z are working loads

* Vibration might occur when the effective stroke is longer than 650mm.
The maximum speed should be decreased by 15% for every 100mm of increased stroke.
** The load condition is based on 10,000km operation.
*** If used on the vertical axis or in a special condition, please contact HIWIN.

Model Number for KA136-FD

KA136	-20	P	-1050	A	FD	U	S1	M201
Model	Lead	Precision Grade	Effective Stroke	Slider Type	Motor Flange	Cover	Limit Switch	Motor
	5 mm 10 mm 20 mm	C: Normal P: Precision		A: Standard	FD: Bottom	U: Without Cover None : Standard Cover	S1: OMRON SX671 S2: OMRON SX674 S3: Panasonic GX-F12A S4: Panasonic GX-F12A-P None: No Limit Switch	M20□, K20□ M40□, K40□ Motor specification: ref. catalog P.167 M: customer specified None: Without Motor

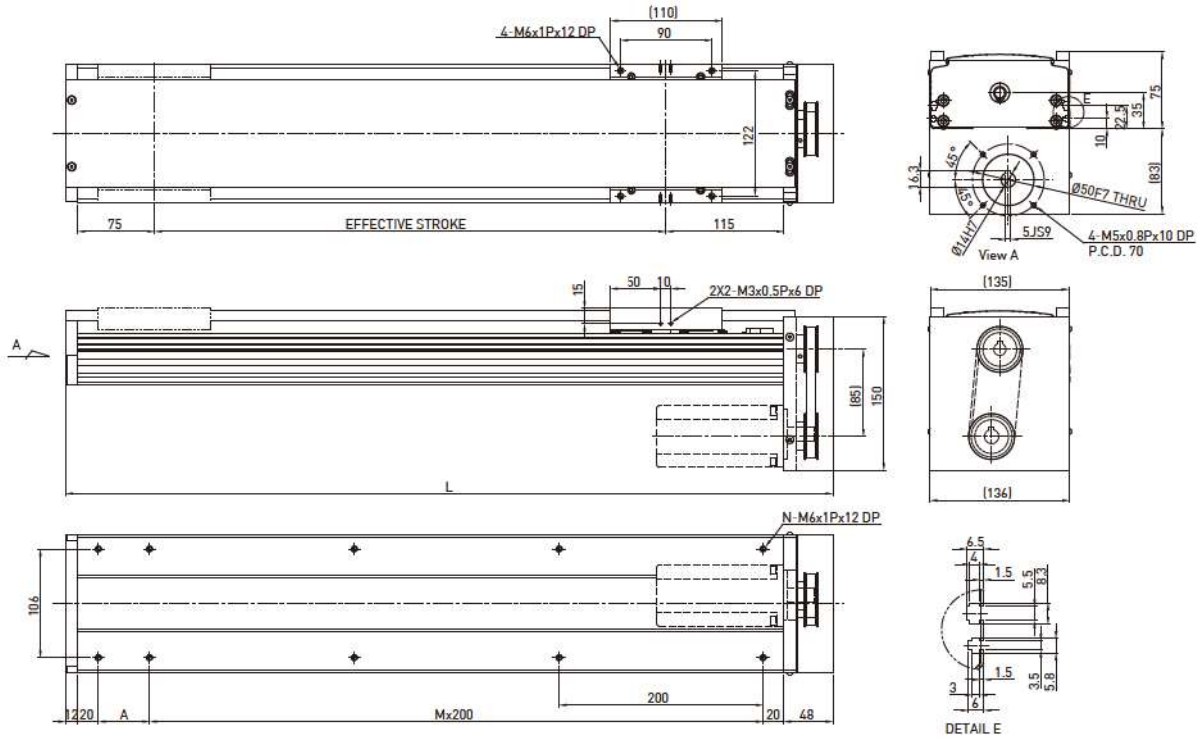

Effective stroke (mm)	L	A	M	N	Weight (kg)	AC motor output					
						W	200				
100	350	50	1	6	6.31	Drive					
150	400	100	1	6	6.88	Ballscrew C7(normal)					
200	450	150	1	6	7.44	Lead					
250	500	200	1	6	8.01	mm 5 10 20					
300	550	50	2	8	8.56	Rated RPM					
350	600	100	2	8	9.12	RPM 3000 3000 3000					
400	650	150	2	8	9.68	Max linear speed*					
450	700	200	2	8	10.25	mm/sec 250 500 1000					
500	750	50	3	10	10.81	Rated thrust					
550	800	100	3	10	11.37	N 560 280 140					
600	850	150	3	10	11.94	Repeatability					
650	900	200	3	10	12.51	mm ±0.02					
700	950	50	4	12	13.06	Effective stroke					
750	1000	100	4	12	13.62	mm 100~1050					
800	1050	150	4	12	14.18	Max load (H)					
850	1100	200	4	12	14.74	kg 95 75 40					
900	1150	50	5	14	15.3		Fyd	N	50	50	50
950	1200	100	5	14	15.86		Fzd	N	950	750	400
1000	1250	150	5	14	16.42		Mxd	N-m	21	21	26
1050	1300	200	5	14	16.98		Myd	N-m	17	17	21
							Mzd	N-m	17	17	21
Rated dynamic load**						$\frac{F_y}{F_{yd}} + \frac{F_z}{F_{zd}} + \frac{M_x}{M_{xd}} + \frac{M_y}{M_{yd}} + \frac{M_z}{M_{zd}} \leq 1$ Fy, Fz, Mx, My, Mz are working loads					
Permitted load condition***											

* Vibration might occur when the effective stroke is longer than 650mm.
 The maximum speed should be decreased by 15% for every 100mm of increased stroke.
 ** The load condition is based on 10,000km operation.
 *** If used on the vertical axis or in a special condition, please contact HIWIN.

Model Number for KA136-FI

KA136	-20	P	-1050	A	FI	U	S1	M201
Model	Lead	Precision Grade	Effective Stroke	Slider Type	Motor Flange	Cover	Limit Switch	Motor
	5 mm 10 mm 20 mm	C: Normal P: Precision		A: Standard	FI : Internal	U: Without Cover None : Standard Cover	S1: OMRON SX671 S2: OMRON SX674 S3: Panasonic GX-F12A S4: Panasonic GX-F12A-P None: No Limit Switch	M20□, K20□ M40□, K40□ Motor specification: ref. catalog P.167 M: customer specified None: Without Motor

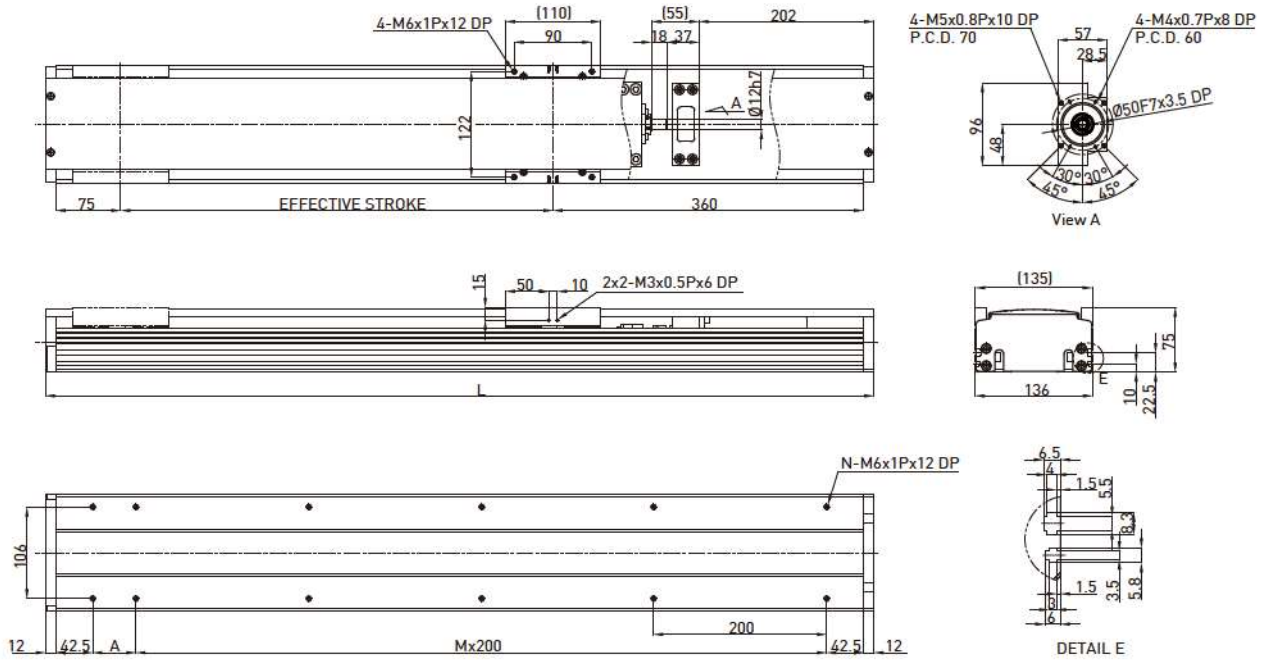

Effective stroke (mm)	L	A	M	N	Weight (kg)	AC motor output			W																											
						Drive	Lead	Rated RPM	mm																											
100	559	50	2	8	6.62		5	3000	200																											
150	609	100	2	8	7.21		10	3000																												
200	659	150	2	8	7.8		20	3000																												
250	709	200	2	8	8.39		250	500																												
300	759	50	3	10	8.98		560	280																												
350	809	100	3	10	9.57			140																												
400	859	150	3	10	10.15			±0.02																												
450	909	200	3	10	10.75			100-1050																												
500	959	50	4	12	11.34																															
550	1009	100	4	12	11.93																															
600	1059	150	4	12	12.52																															
650	1109	200	4	12	13.11																															
700	1159	50	5	14	13.71																															
750	1209	100	5	14	14.29																															
800	1259	150	5	14	14.87																															
850	1309	200	5	14	15.46																															
900	1359	50	6	16	16.05																															
950	1409	100	6	16	16.64																															
1000	1459	150	6	16	17.23																															
1050	1509	200	6	16	17.82																															
						Rated dynamic load**			<table border="1"> <tr> <td>F_{yd}</td> <td>N</td> <td>50</td> <td>50</td> <td>50</td> </tr> <tr> <td>F_{zd}</td> <td>N</td> <td>950</td> <td>750</td> <td>400</td> </tr> <tr> <td>M_{xd}</td> <td>N-m</td> <td>21</td> <td>21</td> <td>26</td> </tr> <tr> <td>M_{yd}</td> <td>N-m</td> <td>17</td> <td>17</td> <td>21</td> </tr> <tr> <td>M_{zd}</td> <td>N-m</td> <td>17</td> <td>17</td> <td>21</td> </tr> </table>			F _{yd}	N	50	50	50	F _{zd}	N	950	750	400	M _{xd}	N-m	21	21	26	M _{yd}	N-m	17	17	21	M _{zd}	N-m	17	17	21
F _{yd}	N	50	50	50																																
F _{zd}	N	950	750	400																																
M _{xd}	N-m	21	21	26																																
M _{yd}	N-m	17	17	21																																
M _{zd}	N-m	17	17	21																																
						Permitted load condition***			$\frac{F_y}{F_{yd}} + \frac{F_z}{F_{zd}} + \frac{M_x}{M_{xd}} + \frac{M_y}{M_{yd}} + \frac{M_z}{M_{zd}} \leq 1$ <p>F_y, F_z, M_x, M_y, M_z are working loads</p>																											

* Vibration might occur when the effective stroke is longer than 650mm.
 The maximum speed should be decreased by 15% for every 100mm of increased stroke.
 ** The load condition is based on 10,000km operation.
 *** If used on the vertical axis or in a special condition, please contact HIWIN.

Model Number for KA136-FL

KA136	-20	P	-1050	A	FL	U	S1	M201
Model	Lead	Precision Grade	Effective Stroke	Slider Type	Motor Flange	Cover	Limit Switch	Motor
	5 mm 10 mm 20 mm	C: Normal P: Precision		A: Standard	FL: Left	U: Without Cover None : Standard Cover	S1: OMRON SX671 S2: OMRON SX674 S3: Panasonic GX-F12A S4: Panasonic GX-F12A-P None: No Limit Switch	M20□, K20□ M40□, K40□ Motor specification: ref. catalog P.167 M:customer specified None:Without Motor

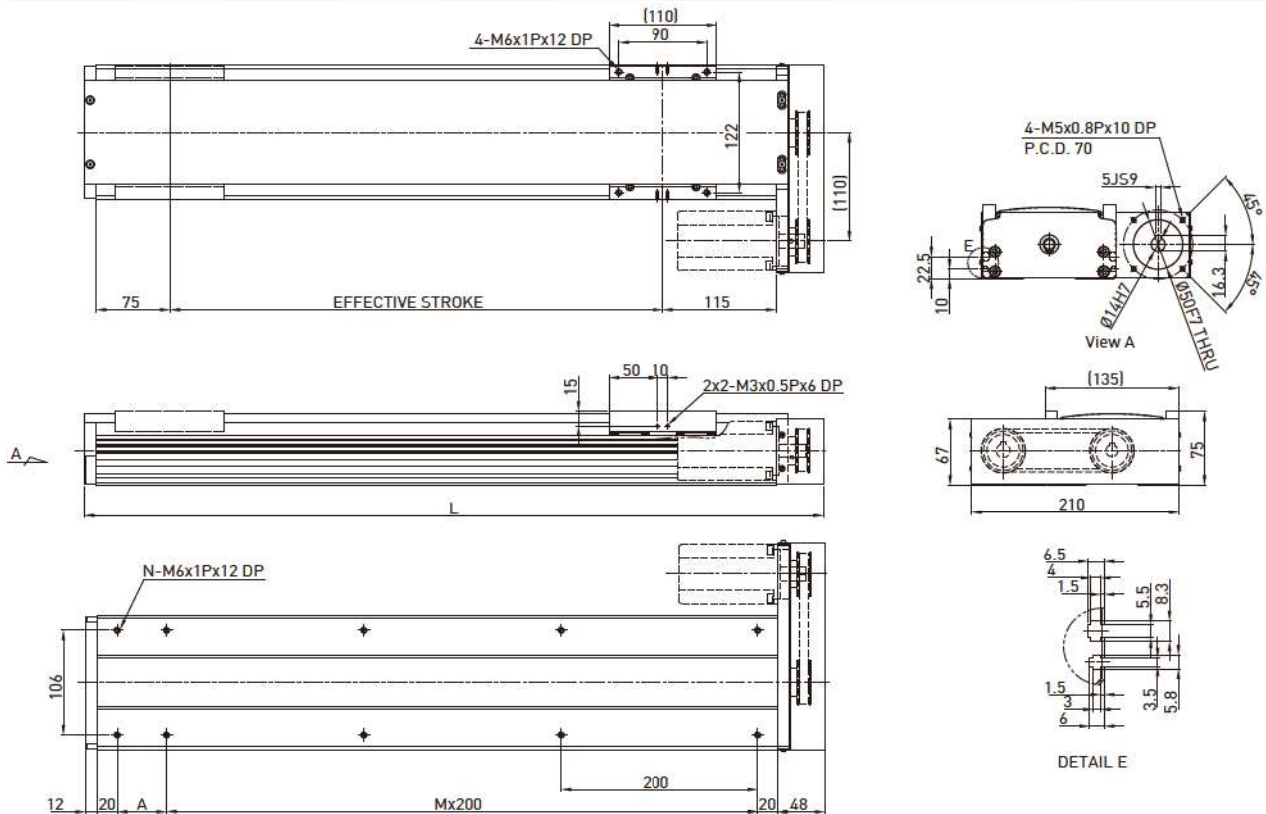

Effective stroke (mm)	L	A	M	N	Weight (kg)	AC motor output	W	200		
100	350	50	1	6	6.31	Drive	Ballscrew C7(normal)			
150	400	100	1	6	6.88	Lead	mm	5 10 20		
200	450	150	1	6	7.44	Rated RPM	RPM	3000 3000 3000		
250	500	200	1	6	8.01	Max linear speed*	mm/sec	250 500 1000		
300	550	50	2	8	8.56	Rated thrust	N	560 280 140		
350	600	100	2	8	9.12	Repeatability	mm	±0.02		
400	650	150	2	8	9.68	Effective stroke	mm	100~1050		
450	700	200	2	8	10.25	Max load (H)	kg	95 75 40		
500	750	50	3	10	10.81		Fyd	N	50 50 50	
550	800	100	3	10	11.37		Fzd	N	950 750 400	
600	850	150	3	10	11.94		Mxd	N-m	21 21 26	
650	900	200	3	10	12.51		Myd	N-m	17 17 21	
700	950	50	4	12	13.06		Mzd	N-m	17 17 21	
750	1000	100	4	12	13.62					
800	1050	150	4	12	14.18	Rated dynamic load**	$\frac{F_y}{F_{yd}} + \frac{F_z}{F_{zd}} + \frac{M_x}{M_{xd}} + \frac{M_y}{M_{yd}} + \frac{M_z}{M_{zd}} \leq 1$ Fy, Fz, Mx, My, Mz are working loads			
850	1100	200	4	12	14.74		Permitted load condition***			
900	1150	50	5	14	15.3					
950	1200	100	5	14	15.86					
1000	1250	150	5	14	16.42					
1050	1300	200	5	14	16.98					

* Vibration might occur when the effective stroke is longer than 650mm.
 The maximum speed should be decreased by 15% for every 100mm of increased stroke.
 ** The load condition is based on 10,000km operation.
 *** If used on the vertical axis or in a special condition, please contact HIWIN.

Model Number for KA136-FR

KA136	-20	P	-1050	A	FR	U	S1	M201
Model	Lead	Precision Grade	Effective Stroke	Slider Type	Motor Flange	Cover	Limit Switch	Motor
	5 mm 10 mm 20 mm	C: Normal P: Precision		A: Standard	FR: Right	U: Without Cover None : Standard Cover	S1: OMRON SX671 S2: OMRON SX674 S3: Panasonic GX-F12A S4: Panasonic GX-F12A-P None: No Limit Switch	M20□, K20□ M40□, K40□ Motor specification: ref. catalog P.167 M:customer specified None:Without Motor

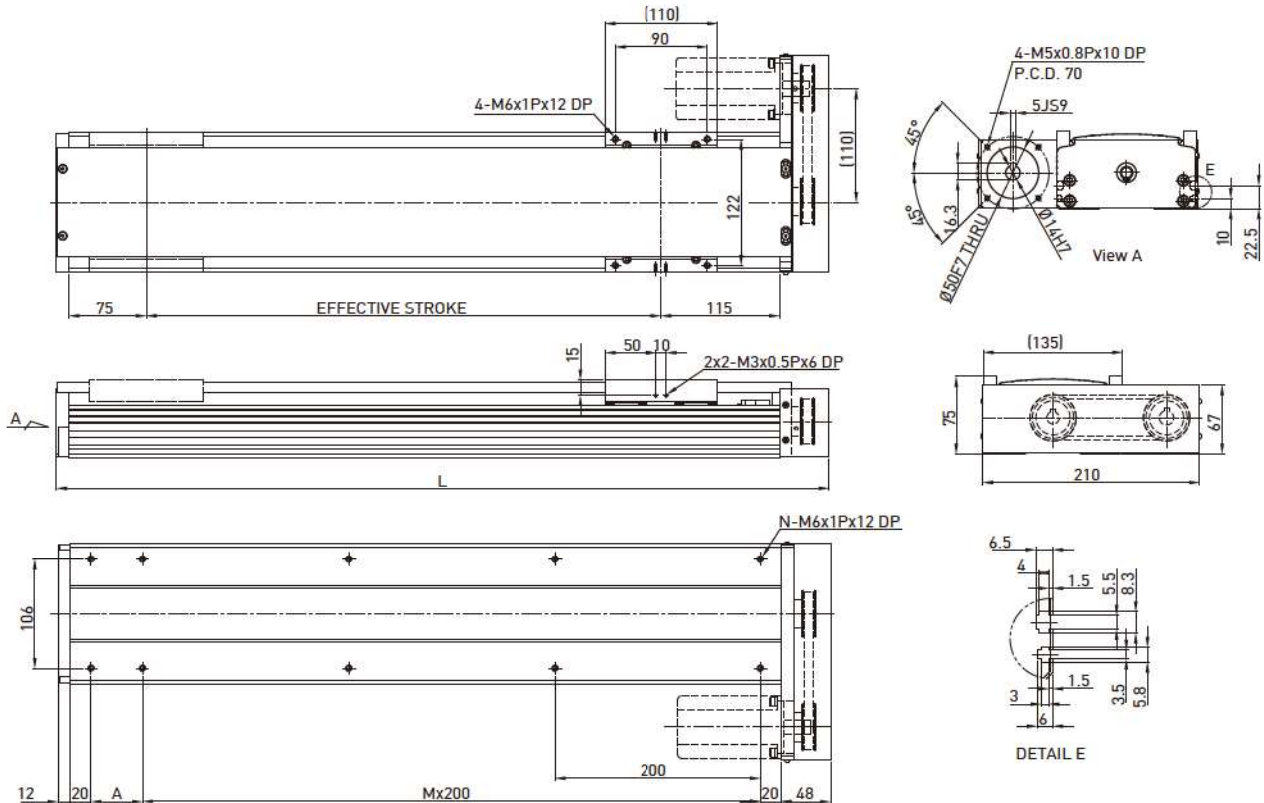

Effective stroke (mm)	L	A	M	N	Weight (kg)	AC motor output	W	200	
100	350	50	1	6	6.31	Drive		Ballscrew C7(normal)	
150	400	100	1	6	6.88	Lead	mm	5 10 20	
200	450	150	1	6	7.44	Rated RPM	RPM	3000 3000 3000	
250	500	200	1	6	8.01	Max linear speed*	mm/sec	250 500 1000	
300	550	50	2	8	8.56	Rated thrust	N	560 280 140	
350	600	100	2	8	9.12	Repeatability	mm	±0.02	
400	650	150	2	8	9.68	Effective stroke	mm	100-1050	
450	700	200	2	8	10.25	Max load (H)	kg	95 75 40	
500	750	50	3	10	10.81		Fyd	N	50 50 50
550	800	100	3	10	11.37		Fzd	N	950 750 400
600	850	150	3	10	11.94		Mxd	N-m	21 21 26
650	900	200	3	10	12.51		Myd	N-m	17 17 21
700	950	50	4	12	13.06		Mzd	N-m	17 17 21
750	1000	100	4	12	13.62	Permitted load condition*** $\frac{F_y}{F_{yd}} + \frac{F_z}{F_{zd}} + \frac{M_x}{M_{xd}} + \frac{M_y}{M_{yd}} + \frac{M_z}{M_{zd}} \leq 1$ Fy, Fz, Mx, My, Mz are working loads			
800	1050	150	4	12	14.18				
850	1100	200	4	12	14.74				
900	1150	50	5	14	15.3				
950	1200	100	5	14	15.86				
1000	1250	150	5	14	16.42				
1050	1300	200	5	14	16.98				

* Vibration might occur when the effective stroke is longer than 650mm.
 The maximum speed should be decreased by 15% for every 100mm of increased stroke.
 ** The load condition is based on 10,000km operation.
 *** If used on the vertical axis or in a special condition, please contact HIWIN.

Model Number for KA136B-FL

KA136	B	-120	C	-3000	A	FL	U	S1	M201
Model	Timing Belt	Pulley Perimeter	Precision Grade	Effective Stroke	Slider Type	Motor Flange	Cover	Limit Switch	Motor
			C: Normal		A: Standard	FL: Left	U: Without Cover None: Standard Cover	S1: OMRON SX671 S2: OMRON SX674 S3: Panasonic GX-F12A S4: Panasonic GX-F12A-P None: No Limit Switch	M20□, K20□ M40□, K40□ Motor specification: ref. catalog P.167 M: customer specified None: Without Motor

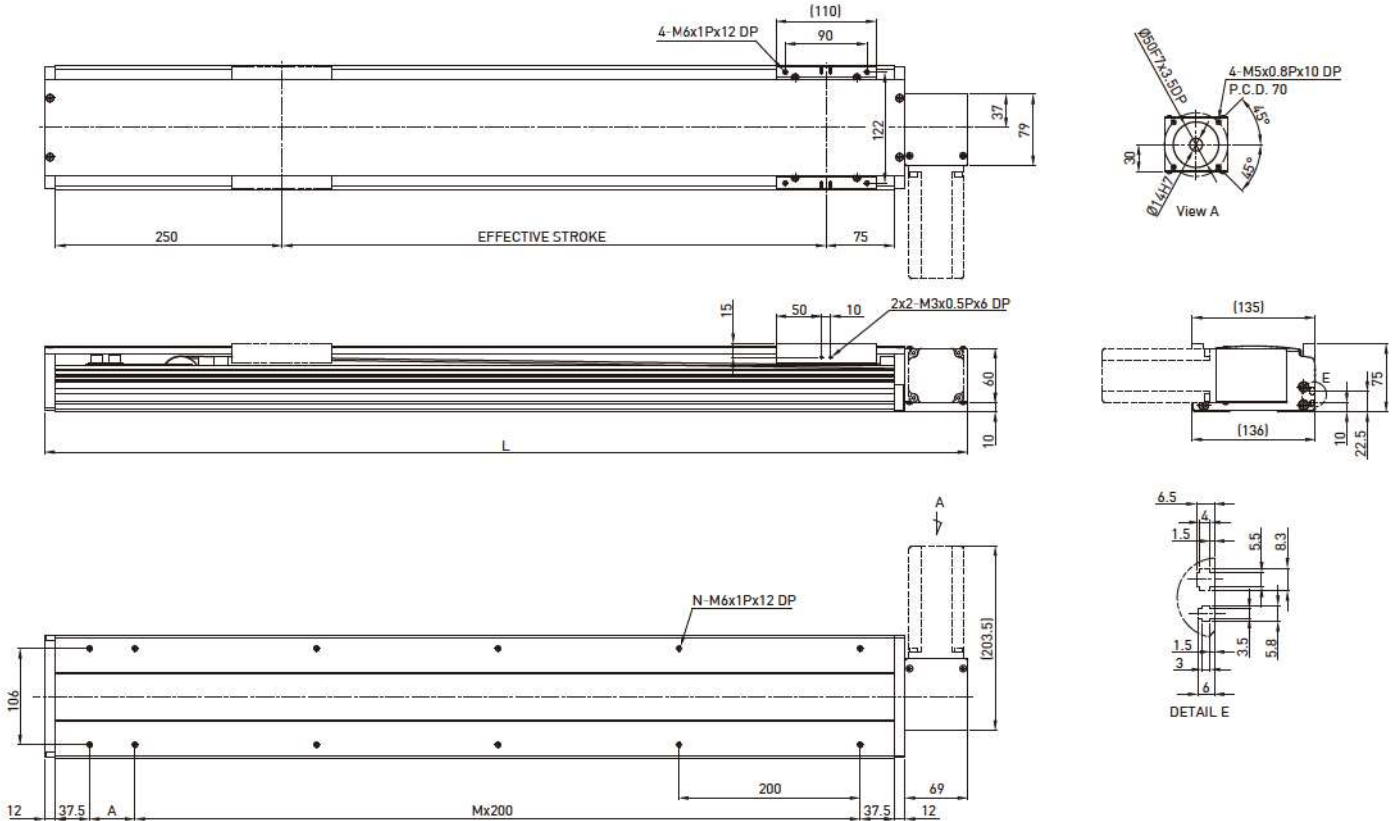

Effective stroke (mm)	L	A	M	N	Weight (kg)	AC motor output Drive	W	200	
200	618	50	2	8	6.97	Pulley Perimeter	mm	120	
400	818	50	3	10	8.93	Pulley RPM	RPM	900	
600	1018	50	4	12	11.01	Max linear speed	mm/sec	1800	
800	1218	50	5	14	12.97	Rated thrust	N	67	
1000	1418	50	6	16	14.93	Repeatability	mm	±0.1	
1200	1618	50	7	18	16.99	Effective stroke	mm	200~3000	
1400	1818	50	8	20	18.95	Max load (H)	kg	15	
1600	2018	50	9	22	21.01	Rated dynamic load*	F _{yd}	N	50
1800	2218	50	10	24	22.97		F _{zd}	N	150
2000	2418	50	11	26	24.93		M _{xd}	N-m	29
2200	2618	50	12	28	26.99		M _{yd}	N-m	24
2400	2818	50	13	30	28.95		M _{zd}	N-m	24
2600	3018	50	14	32	31.01		Permitted load condition** $\frac{F_y}{F_{yd}} + \frac{F_z}{F_{zd}} + \frac{M_x}{M_{xd}} + \frac{M_y}{M_{yd}} + \frac{M_z}{M_{zd}} \leq 1$ F _y , F _z , M _x , M _y , M _z are working loads		
2800	3218	50	15	34	32.97				
3000	3418	50	16	36	34.93				

*The load condition is based on 10,000km operation.

**For horizontal applications only. If used in a special condition, please contact HIWIN.

Model Number for KA136B-FR

KA136	B	-120	C	-3000	A	FR	U	S1	M201
Model	Timing Belt	Pulley Perimeter	Precision Grade	Effective Stroke	Slider Type	Moto Flange	Cover	Limit Switch	Motor
			C: Normal		A: Standard	FR: Right	U: Without Cover None : Standard Cover	S1: OMRON SX671 S2: OMRON SX674 S3: Panasonic GX-F12A S4: Panasonic GX-F12A-P None: No Limit Switch	M20□, K20□ M40□, K40□ Motor specification: ref. catalog P.167 M: customer specified None: Without Motor

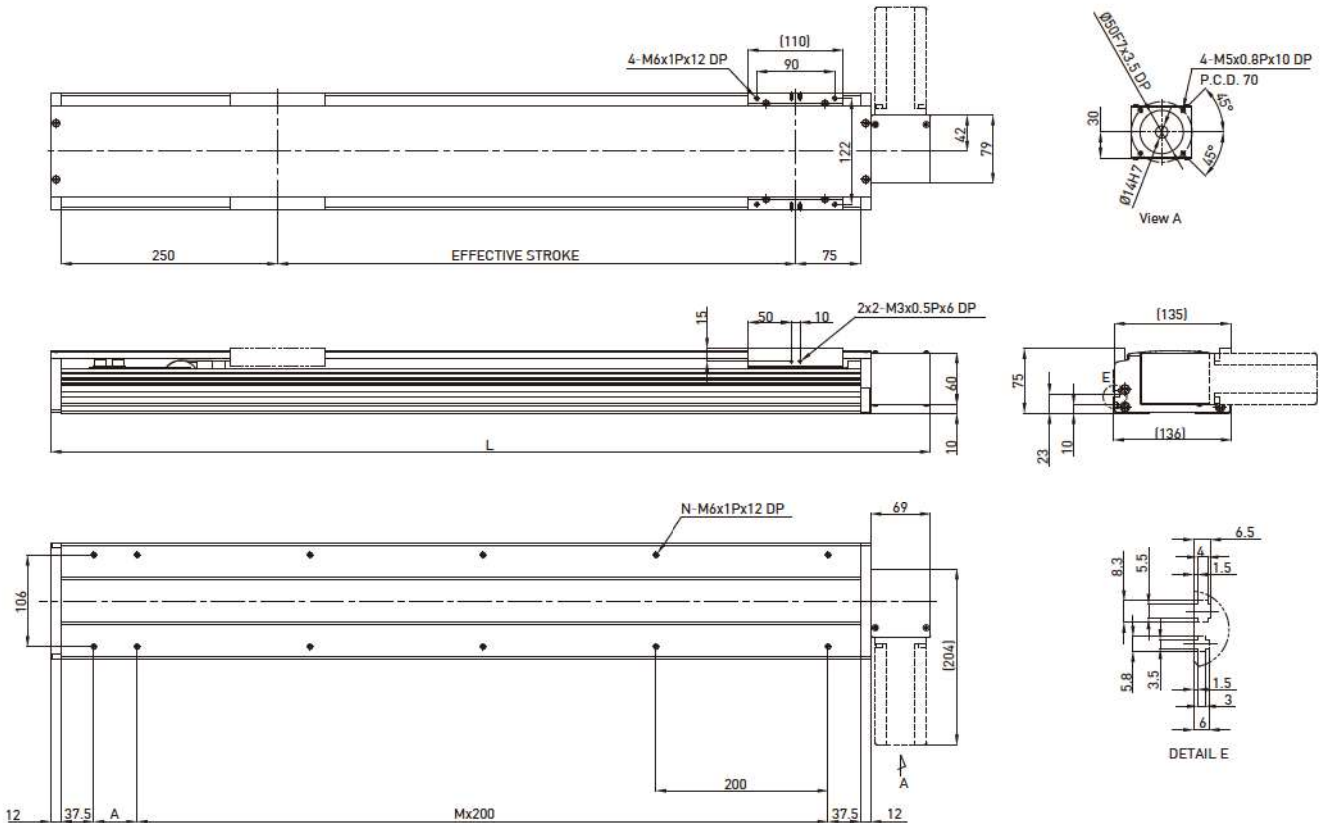

Effective stroke (mm)	L	A	M	N	Weight (kg)	AC motor output Drive	W	
200	618	50	2	8	6.97	Pulley Perimeter	200	
400	818	50	3	10	8.93	Pulley RPM	Timing Belt	
600	1018	50	4	12	11.01	Max linear speed	mm	
800	1218	50	5	14	12.97	Rated thrust	RPM	
1000	1418	50	6	16	14.93	Repeatability	mm/sec	
1200	1618	50	7	18	16.99	Effective stroke	N	
1400	1818	50	8	20	18.95	Max load (H)	mm	
1600	2018	50	9	22	21.01		kg	
1800	2218	50	10	24	22.97		Fyd	N
2000	2418	50	11	26	24.93		Fzd	N
2200	2618	50	12	28	26.99		Mxd	N-m
2400	2818	50	13	30	28.95		Myd	N-m
2600	3018	50	14	32	31.01	Mzd	N-m	
2800	3218	50	15	34	32.97	Permitted load condition** $\frac{F_y}{F_{yd}} + \frac{F_z}{F_{zd}} + \frac{M_x}{M_{xd}} + \frac{M_y}{M_{yd}} + \frac{M_z}{M_{zd}} \leq 1$ Fy, Fz, Mx, My, Mz are working loads		
3000	3418	50	16	36	34.93			

*The load condition is based on 10,000km operation.

**For horizontal applications only. If used in a special condition, please contact HIWIN.

Model Number for KA150

KA150	-10	P	-1250	A	F0	U	S1	M201
Model	Lead	Precision Grade	Effective Stroke	Slider Type	Motor Flange	Cover	Limit Switch	Motor
	10 mm 20 mm	C: Normal P: Precision		A: Standard	F0 : Direct	U: Without Cover None : Standard Cover	S1: OMRON SX671 S2: OMRON SX674 S3: Panasonic GX-F12A S4: Panasonic GX-F12A-P None: No Limit Switch	M20□, K20□ M40□, K40□ Motor specification: ref. catalof P.167 M:customer specified None:Without Motor

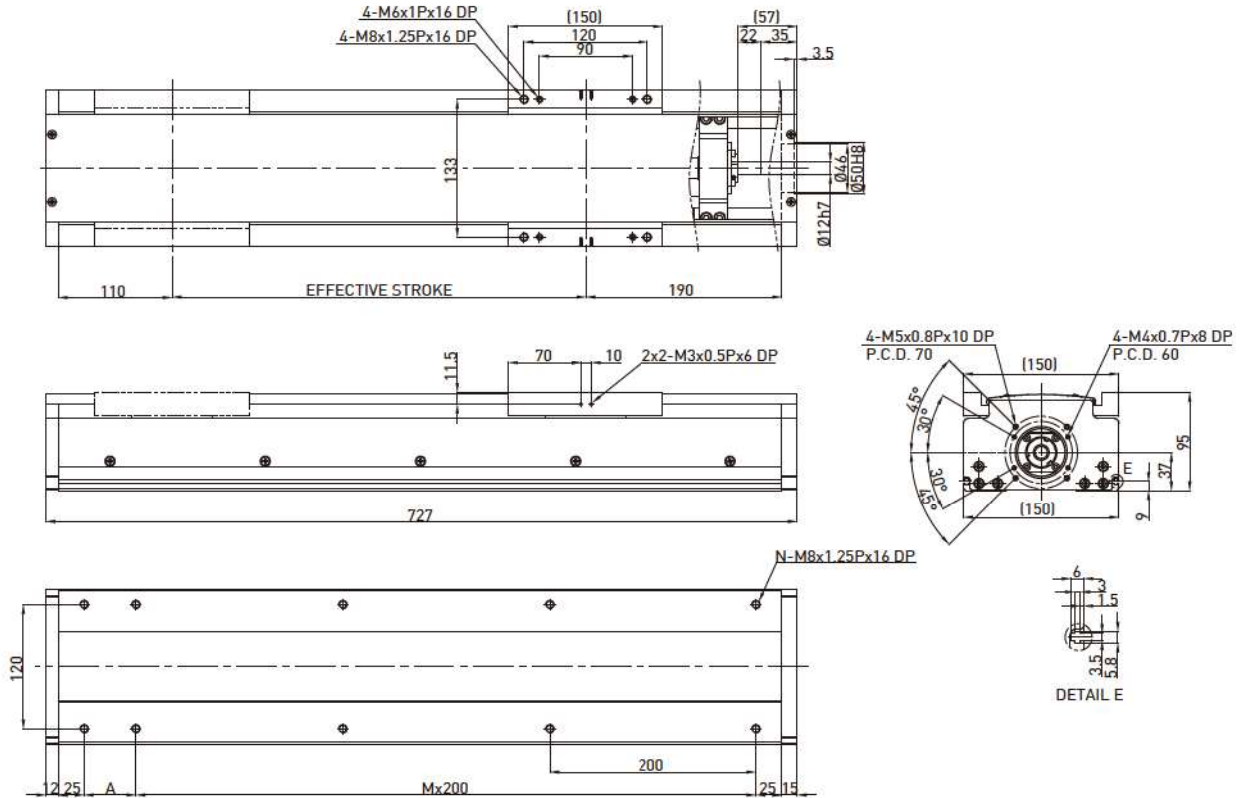

Effective stroke (mm)	L	A	M	N	Weight (kg)	AC motor output	W	200	
150	477	200	1	6	12.71	Drive	Ballscrew C7(normal)		
200	527	50	2	8	13.59	Lead	mm	10 20	
250	577	100	2	8	14.47	Rated RPM	RPM	3000 3000	
300	627	150	2	8	15.35	Max linear speed*	mm/sec	500 1000	
350	677	200	2	8	16.23	Rated thrust	N	280 140	
400	727	50	3	10	17.11	Repeatability	mm	±0.02	
450	777	100	3	10	17.99	Effective stroke	mm	150~1250	
500	827	150	3	10	18.87	Max load (H)	kg	80 40	
550	877	200	3	10	19.75		Fyd	N	50 50
600	927	50	4	12	20.63		Fzd	N	800 400
650	977	100	4	12	21.51		Mxd	N-m	56 63
700	1027	150	4	12	22.39		Myd	N-m	49 53
750	1077	200	4	12	23.27		Mzd	N-m	49 53
800	1127	50	5	14	24.15				
850	1177	100	5	14	25.03	Permitted load condition*** $\frac{F_y}{F_{yd}} + \frac{F_z}{F_{zd}} + \frac{M_x}{M_{xd}} + \frac{M_y}{M_{yd}} + \frac{M_z}{M_{zd}} \leq 1$ Fy, Fz, Mx, My, Mz are working loads			
900	1227	150	5	14	25.91				
950	1277	200	5	14	26.79				
1000	1327	50	6	16	27.67				
1050	1377	100	6	16	28.55				
1100	1427	150	6	16	29.43				
1150	1477	200	6	16	30.31				
1200	1527	50	7	18	31.19				
1250	1577	100	7	18	32.07				

* Vibration might occur when the effective stroke is longer than 650mm. The maximum speed should be decreased by 15% for every 100mm of increased stroke.
 ** The load condition is based on 10,000km operation.
 *** If used on the vertical axis or in a special condition, please contact HIWIN.

Model Number for KA170

KA170	-20	P	-1250	A	F0	U	S1	M401
Model	Lead	Precision Grade	Effective Stroke	Slider Type	Motor Flange	Cover	Limit Switch	Motor
	10 mm 20 mm	C: Normal P: Precision		A: Standard	F0 : Direct	U: Without Cover None : Standard Cover	S1: OMRON SX671 S2: OMRON SX674 S3: Panasonic GX-F12A S4: Panasonic GX-F12A-P None: No Limit Switch	M40□, K40□ M75□, K75□ Motor specification: ref. catalof P.167 M:customer specified None:Without Motor

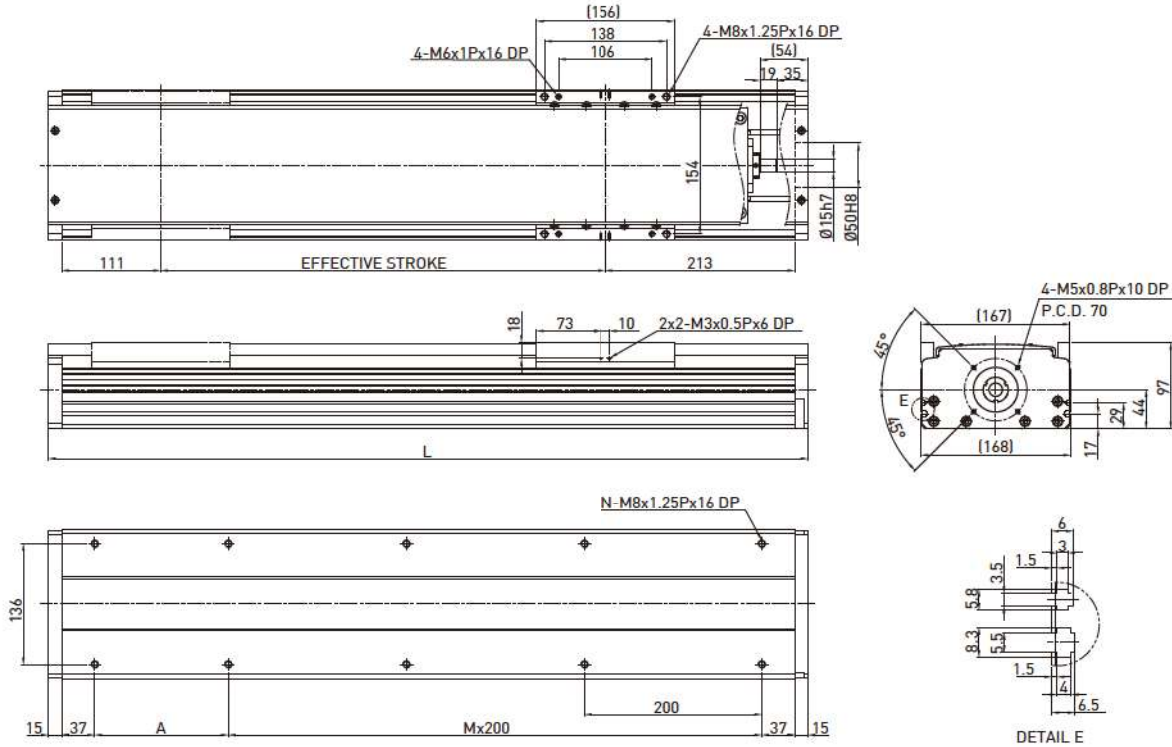

Effective stroke (mm)	L	A	M	N	Weight (kg)	AC motor output	W	400	
150	504	200	1	6	14.57	Drive		Ballscrew C7(normal)	
200	554	50	2	8	15.45	Lead	mm	10 20	
250	604	100	2	8	16.33	Rated RPM	RPM	3000 3000	
300	654	150	2	8	17.21	Max linear speed*	mm/sec	500 1000	
350	704	200	2	8	18.09	Rated thrust	N	560 280	
400	754	50	3	10	18.97	Repeatability	mm	±0.02	
450	804	100	3	10	19.85	Effective stroke	mm	150-1250	
500	854	150	3	10	20.73	Max load (H)	kg	125 75	
550	904	200	3	10	21.61		Fyd	N	50 50
600	954	50	4	12	22.49		Fzd	N	1250 750
650	1004	100	4	12	23.37		Mxd	N-m	100 110
700	1054	150	4	12	24.25		Myd	N-m	85 90
750	1104	200	4	12	25.13		Mzd	N-m	85 90
800	1154	50	5	14	26.01		$\frac{F_y}{F_{yd}} + \frac{F_z}{F_{zd}} + \frac{M_x}{M_{xd}} + \frac{M_y}{M_{yd}} + \frac{M_z}{M_{zd}} \leq 1$ Fy, Fz, Mx, My, Mz are working loads		
850	1204	100	5	14	26.89				
900	1254	150	5	14	27.77	Permitted load condition***			
950	1304	200	5	14	28.65				
1000	1354	50	6	16	29.53				
1050	1404	100	6	16	30.41				
1100	1454	150	6	16	31.29				
1150	1504	200	6	16	32.17				
1200	1554	50	7	18	33.05				
1250	1604	100	7	18	33.92				

* Vibration might occur when the effective stroke is longer than 650mm. The maximum speed should be decreased by 15% for every 100mm of increased stroke.
 ** The load condition is based on 10,000km operation.
 *** If used on the vertical axis or in a special condition, please contact HIWIN.

Model Number for KA170-FD

KA170	-20	P	-1250	A	FD	U	S1	M401
Model	Lead	Precision Grade	Effective Stroke	Slider Type	Motor Flange	Cover	Limit Switch	Motor
	10 mm 20 mm	C: Normal P: Precision		A: Standard	FD: Bottom	U: Without Cover None : Standard Cover	S1: OMRON SX671 S2: OMRON SX674 S3: Panasonic GX-F12A S4: Panasonic GX-F12A-P None: No Limit Switch	M40□ K40□ Motor specification: ref. catalof P.167 M: customer specified None: Without Motor

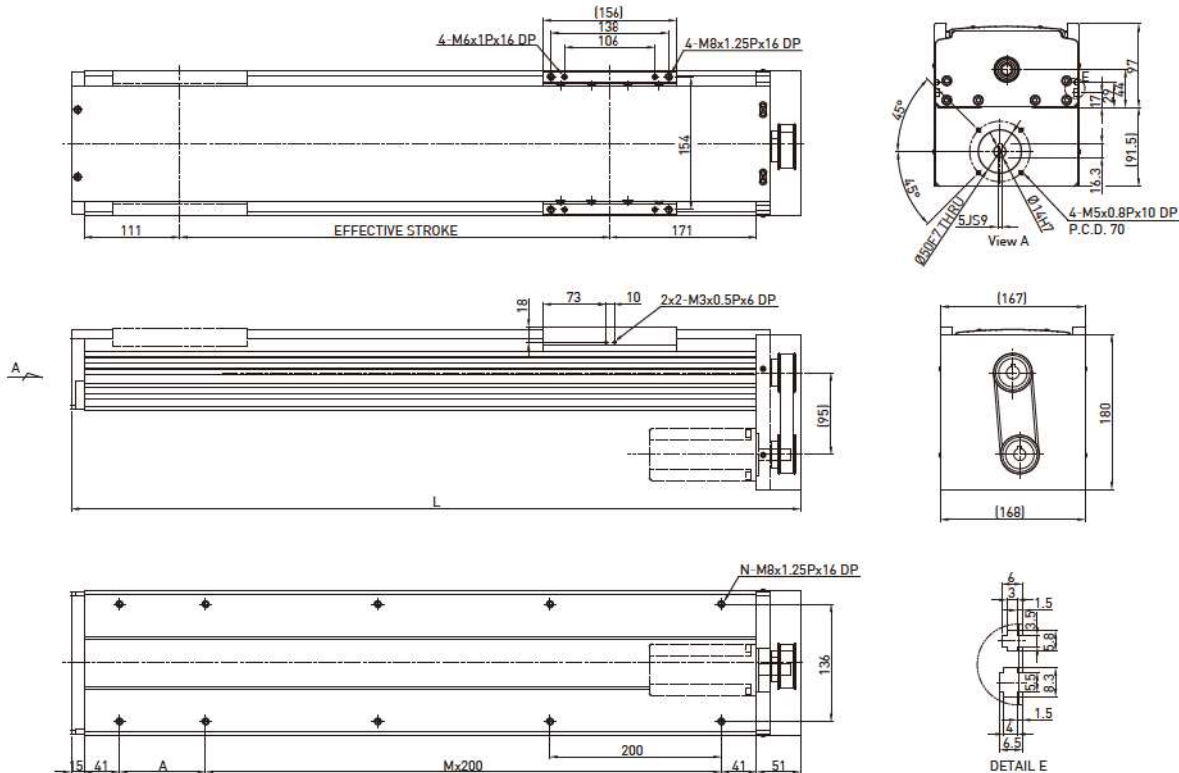

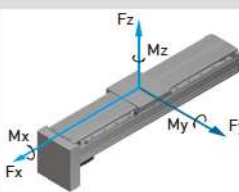
Effective stroke (mm)	L	A	M	N	Weight (kg)	AC motor output	W	400																				
150	498	150	1	6	15.01	Drive		Ballscrew C7(normal)																				
200	548	200	1	6	15.92	Lead	mm	10	20																			
250	598	50	2	8	16.82	Rated RPM	RPM	3000	3000																			
300	648	100	2	8	17.73	Max linear speed*	mm/sec	500	1000																			
350	698	150	2	8	18.63	Rated thrust	N	560	280																			
400	748	200	2	8	19.54	Repeatability	mm	±0.02																				
450	798	50	3	10	20.45	Effective stroke	mm	150~1250																				
500	848	100	3	10	21.35	Max load (H)	kg	125	75																			
550	898	150	3	10	22.26	<div style="display: flex; align-items: center;">  <table border="1" style="margin-left: 20px;"> <tr> <td>Fyd</td> <td>N</td> <td>50</td> <td>50</td> </tr> <tr> <td>Fzd</td> <td>N</td> <td>1250</td> <td>750</td> </tr> <tr> <td>Mxd</td> <td>N-m</td> <td>100</td> <td>110</td> </tr> <tr> <td>Myd</td> <td>N-m</td> <td>85</td> <td>90</td> </tr> <tr> <td>Mzd</td> <td>N-m</td> <td>85</td> <td>90</td> </tr> </table> </div>	Fyd	N	50	50	Fzd	N	1250	750	Mxd	N-m	100	110	Myd	N-m	85	90	Mzd	N-m	85	90		
Fyd	N	50	50																									
Fzd	N	1250	750																									
Mxd	N-m	100	110																									
Myd	N-m	85	90																									
Mzd	N-m	85	90																									
600	948	200	3	10	23.17	Permitted load condition*** $\frac{F_y}{F_{yd}} + \frac{F_z}{F_{zd}} + \frac{M_x}{M_{xd}} + \frac{M_y}{M_{yd}} + \frac{M_z}{M_{zd}} \leq 1$ Fy, Fz, Mx, My, Mz are working loads																						
650	998	50	4	12	24.07																							
700	1048	100	4	12	24.98																							
750	1098	150	4	12	25.89																							
800	1148	200	4	12	26.79																							
850	1198	50	5	14	27.71																							
900	1248	100	5	14	28.61																							
950	1298	150	5	14	29.51																							
1000	1348	200	5	14	30.42																							
1050	1398	50	6	16	31.33																							
1100	1448	100	6	16	32.23																							
1150	1498	150	6	16	33.14																							
1200	1548	200	6	16	34.04																							
1250	1598	50	7	18	34.94																							

* Vibration might occur when the effective stroke is longer than 650mm. The maximum speed should be decreased by 15% for every 100mm of increased stroke.
 ** The load condition is based on 10,000km operation.
 *** If used on the vertical axis or in a special condition, please contact HIWIN.

Model Number for KA170-FI

KA170	-20	P	-1250	A	FI	U	S1	M401
Model	Lead	Precision Grade	Effective Stroke	Slider Type	Motor Flange	Cover	Limit Switch	Motor
	10 mm 20 mm	C: Normal P: Precision		A: Standard	FI : Internal	U: Without Cover None : Standard Cover	S1: OMRON SX671 S2: OMRON SX674 S3: Panasonic GX-F12A S4: Panasonic GX-F12A-P None: No Limit Switch	M40□ K40□ Motor specification: ref. catalog P.167 M:customer specified None:Without Motor

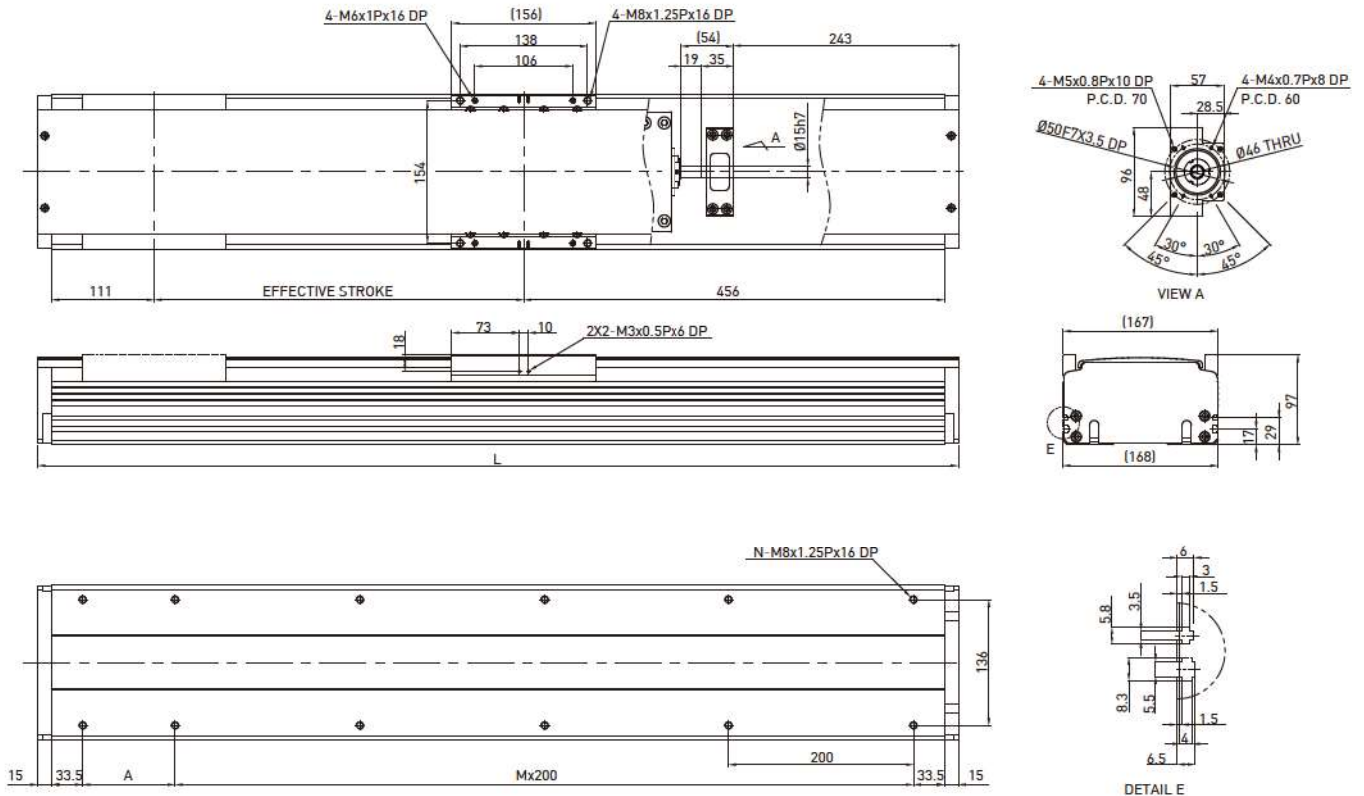

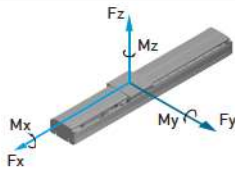
Effective stroke (mm)	L	A	M	N	Weight (kg)	AC motor output	W	400	
150	747	50	3	10	15.59	Drive	Ballscrew C7(normal)		
200	797	100	3	10	16.53	Lead	mm	10 20	
250	847	150	3	10	17.47	Rated RPM	RPM	3000 3000	
300	897	200	3	10	18.42	Max linear speed*	mm/sec	500 1000	
350	947	50	4	12	19.36	Rated thrust	N	560 280	
400	997	100	4	12	20.31	Repeatability	mm	±0.02	
450	1047	150	4	12	23.24	Effective stroke	mm	150-1250	
500	1097	200	4	12	22.18	Max load (H)	kg	125 75	
550	1147	50	5	14	23.12		F _{yd}	N	50 50
600	1197	100	5	14	24.06		F _{zd}	N	1250 750
650	1247	150	5	14	25.01		M _{xd}	N-m	100 110
700	1297	200	5	14	25.95		M _{yd}	N-m	85 90
750	1347	50	6	16	26.89		M _{zd}	N-m	85 90
800	1397	100	6	16	27.83				
850	1447	150	6	16	28.77	Permitted load condition*** $\frac{F_y}{F_{yd}} + \frac{F_z}{F_{zd}} + \frac{M_x}{M_{xd}} + \frac{M_y}{M_{yd}} + \frac{M_z}{M_{zd}} \leq 1$ F _y , F _z , M _x , M _y , M _z are working loads			
900	1497	200	6	16	29.71				
950	1547	50	7	18	30.66				
1000	1597	100	7	18	31.61				
1050	1647	150	7	18	32.54				
1100	1697	200	7	18	33.48				
1150	1747	50	8	20	34.42				
1200	1797	100	8	20	35.36				
1250	1847	150	8	20	36.31				

* Vibration might occur when the effective stroke is longer than 650mm. The maximum speed should be decreased by 15% for every 100mm of increased stroke.
 ** The load condition is based on 10,000km operation.
 *** If used on the vertical axis or in a special condition, please contact HIWIN.

Model Number for KA170-FL

KA170	-20	P	-1250	A	FL	U	S1	M401
Model	Lead	Precision Grade	Effective Stroke	Slider Type	Motor Flange	Cover	Limit Switch	Motor
	10 mm 20 mm	C: Normal P: Precision		A: Standard	FL: Left	U: Without Cover None : Standard Cover	S1: OMRON SX671 S2: OMRON SX674 S3: Panasonic GX-F12A S4: Panasonic GX-F12A-P None: No Limit Switch	M40□ K40□ Motor specification: ref. catalof P.167 M:customer specified None:Without Motor

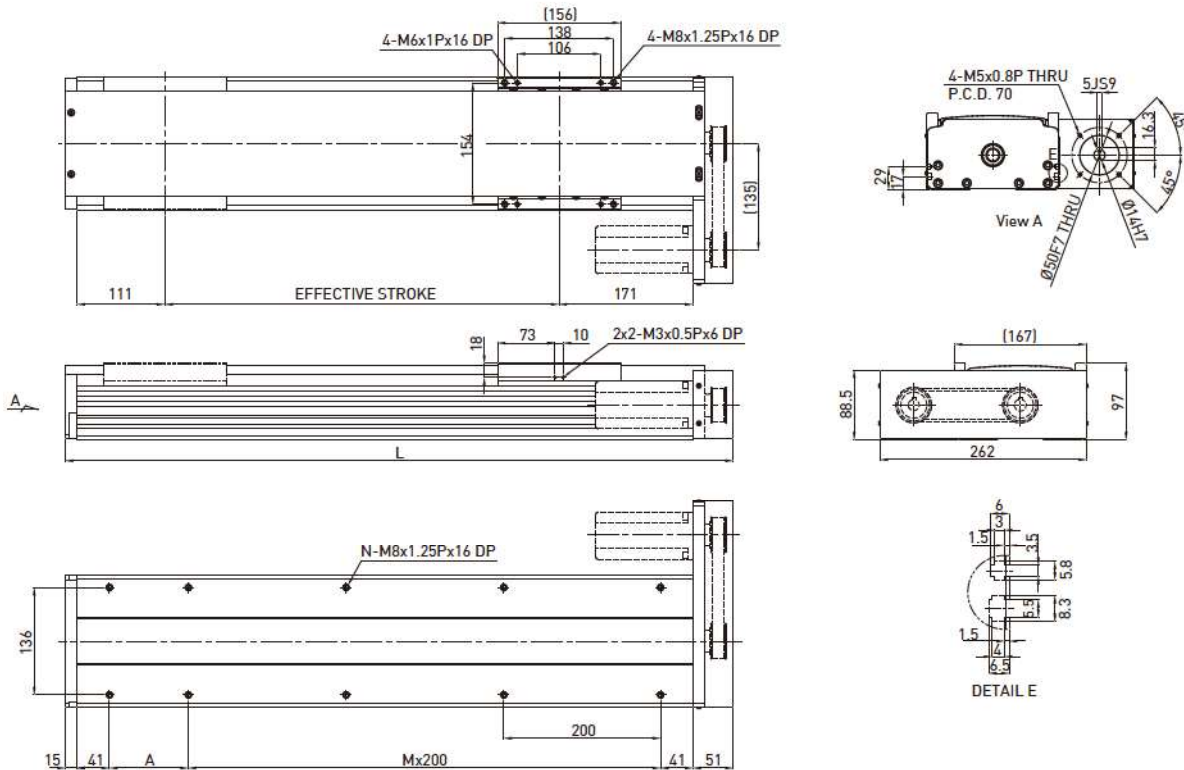

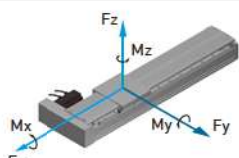
Effective stroke (mm)	L	A	M	N	Weight (kg)	AC motor output	W	400																		
150	498	150	1	6	15.01	Drive	Ballscrew C7(normal)																			
200	548	200	1	6	15.92	Lead	mm	10 20																		
250	598	50	2	8	16.82	Rated RPM	RPM	3000 3000																		
300	648	100	2	8	17.73	Max linear speed*	mm/sec	500 1000																		
350	698	150	2	8	18.63	Rated thrust	N	560 280																		
400	748	200	2	8	19.54	Repeatability	mm	±0.02																		
450	798	50	3	10	20.45	Effective stroke	mm	150~1250																		
500	848	100	3	10	21.35	Max load (H)	kg	125 75																		
550	898	150	3	10	22.26	<div style="display: flex; align-items: center;"> <div style="margin-right: 10px;">Rated dynamic load**</div>  <table border="1" style="margin-left: 10px;"> <tr><td>Fyd</td><td>N</td><td>50</td><td>50</td></tr> <tr><td>Fzd</td><td>N</td><td>1250</td><td>750</td></tr> <tr><td>Mxd</td><td>N-m</td><td>100</td><td>110</td></tr> <tr><td>Myd</td><td>N-m</td><td>85</td><td>90</td></tr> <tr><td>Mzd</td><td>N-m</td><td>85</td><td>90</td></tr> </table> </div>	Fyd	N	50	50	Fzd	N	1250	750	Mxd	N-m	100	110	Myd	N-m	85	90	Mzd	N-m	85	90
Fyd	N	50	50																							
Fzd	N	1250	750																							
Mxd	N-m	100	110																							
Myd	N-m	85	90																							
Mzd	N-m	85	90																							
600	948	200	3	10	23.17																					
650	998	50	4	12	24.07																					
700	1048	100	4	12	24.98																					
750	1098	150	4	12	25.89																					
800	1148	200	4	12	26.79																					
850	1198	50	5	14	27.71	<div style="display: flex; align-items: center;"> <div style="margin-right: 10px;">Permitted load condition***</div> $\frac{F_y}{F_{yd}} + \frac{F_z}{F_{zd}} + \frac{M_x}{M_{xd}} + \frac{M_y}{M_{yd}} + \frac{M_z}{M_{zd}} \leq 1$ <p>Fy, Fz, Mx, My, Mz are working loads</p> </div>																				
900	1248	100	5	14	28.61																					
950	1298	150	5	14	29.51																					
1000	1348	200	5	14	30.42																					
1050	1398	50	6	16	31.33																					
1100	1448	100	6	16	32.23																					
1150	1498	150	6	16	33.14																					
1200	1548	200	6	16	34.04																					
1250	1598	50	7	18	34.94																					

* Vibration might occur when the effective stroke is longer than 650mm. The maximum speed should be decreased by 15% for every 100mm of increased stroke.
 ** The load condition is based on 10,000km operation.
 *** If used on the vertical axis or in a special condition, please contact HIWIN.

Model Number for KA170-FR

KA170	-20	P	-1250	A	FR	U	S1	M401
Model	Lead	Precision Grade	Effective Stroke	Slider Type	Motor Flange	Cover	Limit Switch	Motor
	10 mm 20 mm	C: Normal P: Precision		A: Standard	FR: Right	U: Without Cover None : Standard Cover	S1: OMRON SX671 S2: OMRON SX674 S3: Panasonic GX-F12A S4: Panasonic GX-F12A-P None: No Limit Switch	M40□ K40□ Motor specification: ref. catalof P.167 M:customer specified None:Without Motor

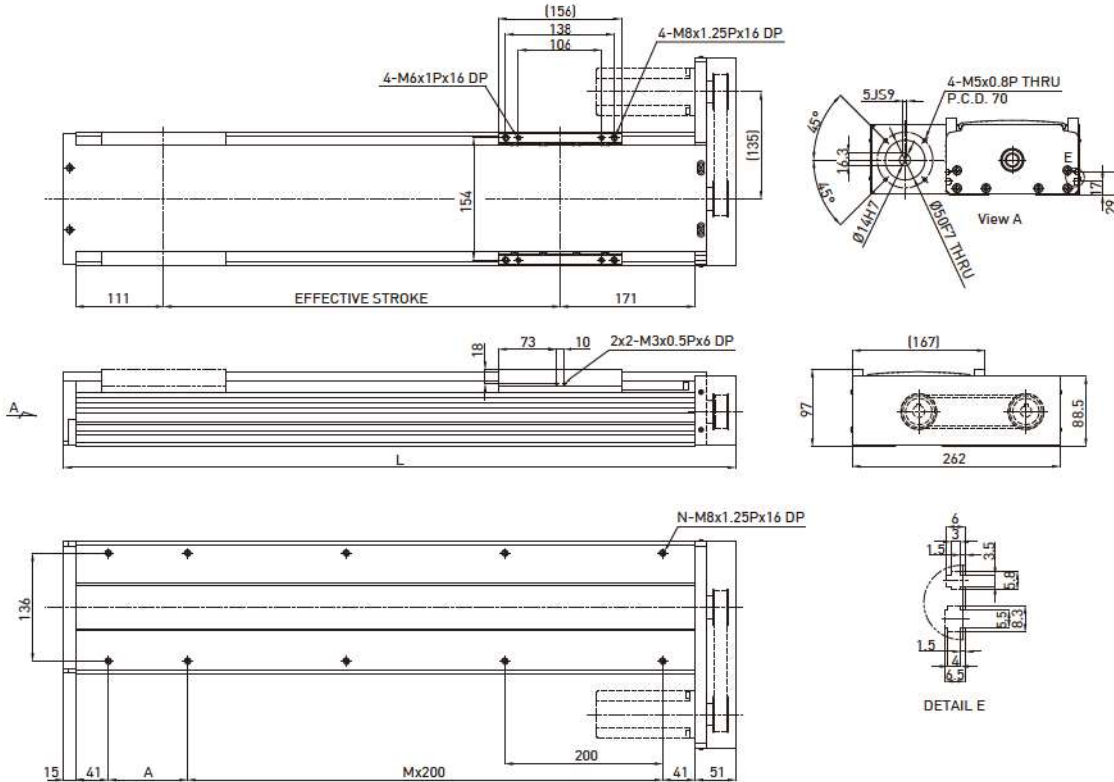

Effective stroke (mm)	L	A	M	N	Weight (kg)	AC motor output		W		
						Drive		400	Ballscrew C7(normal)	
150	498	150	1	6	15.01	Lead	mm	10	20	
200	548	200	1	6	15.92	Rated RPM	RPM	3000	3000	
250	598	50	2	8	16.82	Max linear speed*	mm/sec	500	1000	
300	648	100	2	8	17.73	Rated thrust	N	560	280	
350	698	150	2	8	18.63	Repeatability	mm	±0.02		
400	748	200	2	8	19.54	Effective stroke	mm	150~1250		
450	798	50	3	10	20.45	Max load (H)	kg	125	75	
500	848	100	3	10	21.35	Rated dynamic load**	F _{yd}	N	50	50
550	898	150	3	10	22.26		F _{zd}	N	1250	750
600	948	200	3	10	23.17		M _{xd}	N-m	100	110
650	998	50	4	12	24.07		M _{yd}	N-m	85	90
700	1048	100	4	12	24.98		M _{zd}	N-m	85	90
750	1098	150	4	12	25.89					
800	1148	200	4	12	26.79					
850	1198	50	5	14	27.71					
900	1248	100	5	14	28.61					
950	1298	150	5	14	29.51					
1000	1348	200	5	14	30.42					
1050	1398	50	6	16	31.33	Permitted load condition***	$\frac{F_y}{F_{yd}} + \frac{F_z}{F_{zd}} + \frac{M_x}{M_{xd}} + \frac{M_y}{M_{yd}} + \frac{M_z}{M_{zd}} \leq 1$ F _y , F _z , M _x , M _y , M _z are working loads			
1100	1448	100	6	16	32.23					
1150	1498	150	6	16	33.14					
1200	1548	200	6	16	34.04					
1250	1598	50	7	18	34.94					

* Vibration might occur when the effective stroke is longer than 650mm.
 The maximum speed should be decreased by 15% for every 100mm of increased stroke.
 ** The load condition is based on 10,000km operation.
 *** If used on the vertical axis or in a special condition, please contact HIWIN.

Model Number for KA170B-FL

KA170	B	-120	C	-3000	A	FL	U	S1	M401
Model	Timing Belt	Pulley Perimeter	Precision Grade	Effective Stroke	Slider Type	Motor Flange	Cover	Limit Switch	Motor
			C: Normal		A: Standard	FL: Left	U: Without Cover None : Standard Cover	S1: OMRON SX671 S2: OMRON SX674 S3: Panasonic GX-F12A S4: Panasonic GX-F12A-P None: No Limit Switch	M40□ K40□ Motor specification: ref. catalog P.167 M: customer specified None: Without Motor

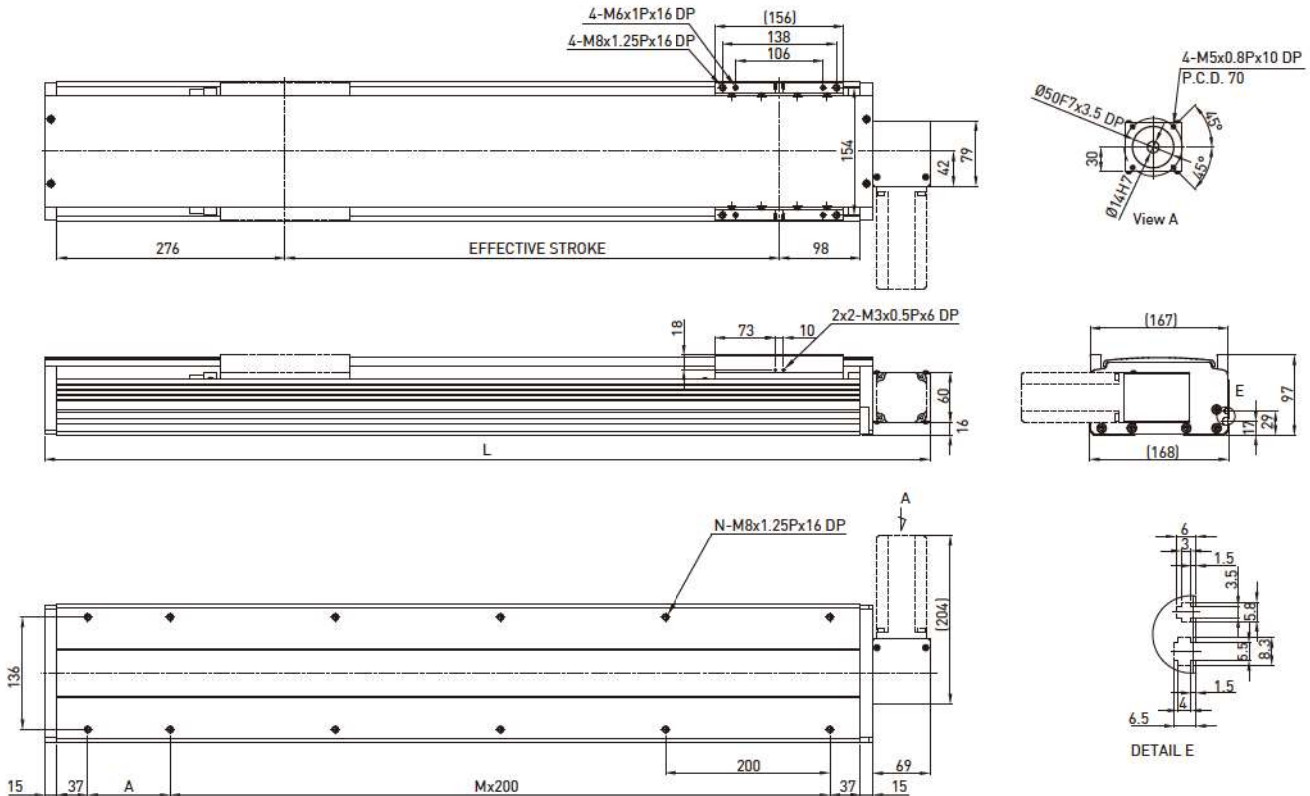

Effective stroke (mm)	L	A	M	N	Weight (kg)	AC motor output Drive	W	400	
200	673	100	2	8	14.74	Pulley Perimeter	mm	120	
400	873	100	3	10	17.88	Pulley RPM	RPM	900	
600	1073	100	4	12	21.13	Max linear speed	mm/sec	1800	
800	1273	100	5	14	24.37	Rated thrust	N	133	
1000	1473	100	6	16	27.52	Repeatability	mm	±0.1	
1200	1673	100	7	18	30.77	Effective stroke	mm	200~3000	
1400	1873	100	8	20	34.01	Max load (H)	kg	30	
1600	2073	100	9	22	37.07	Rated dynamic load*	Fyd	N	50
1800	2273	100	10	24	40.3		Fzd	N	300
2000	2473	100	11	26	43.54		Mxd	N-m	115
2200	2673	100	12	28	46.68		Myd	N-m	96
2400	2873	100	13	30	49.92		Mzd	N-m	96
2600	3073	100	14	32	53.07		Permitted load condition** $\frac{F_y}{F_{yd}} + \frac{F_z}{F_{zd}} + \frac{M_x}{M_{xd}} + \frac{M_y}{M_{yd}} + \frac{M_z}{M_{zd}} \leq 1$ Fy, Fz, Mx, My, Mz are working loads		
2800	3273	100	15	34	56.2				
3000	3473	100	16	36	59.44				

*The load condition is based on 10,000km operation.

**For horizontal applications only. If used in a special condition, please contact HIWIN.

Model Number for KA170B-FR

KA170	B	-120	C	-3000	A	FR	U	S1	M401
Model	Timing Belt	Pulley Perimeter	Precision Grade	Effective Stroke	Slider Type	Motor Flange	Cover	Limit Switch	Motor
			C: Normal		A: Standard	FR: Right	U: Without Cover None: Standard Cover	S1: OMRON SX671 S2: OMRON SX674 S3: Panasonic GX-F12A S4: Panasonic GX-F12A-P None: No Limit Switch	M40□ K40□ Motor specification: ref. catalog P.167 M: customer specified None: Without Motor

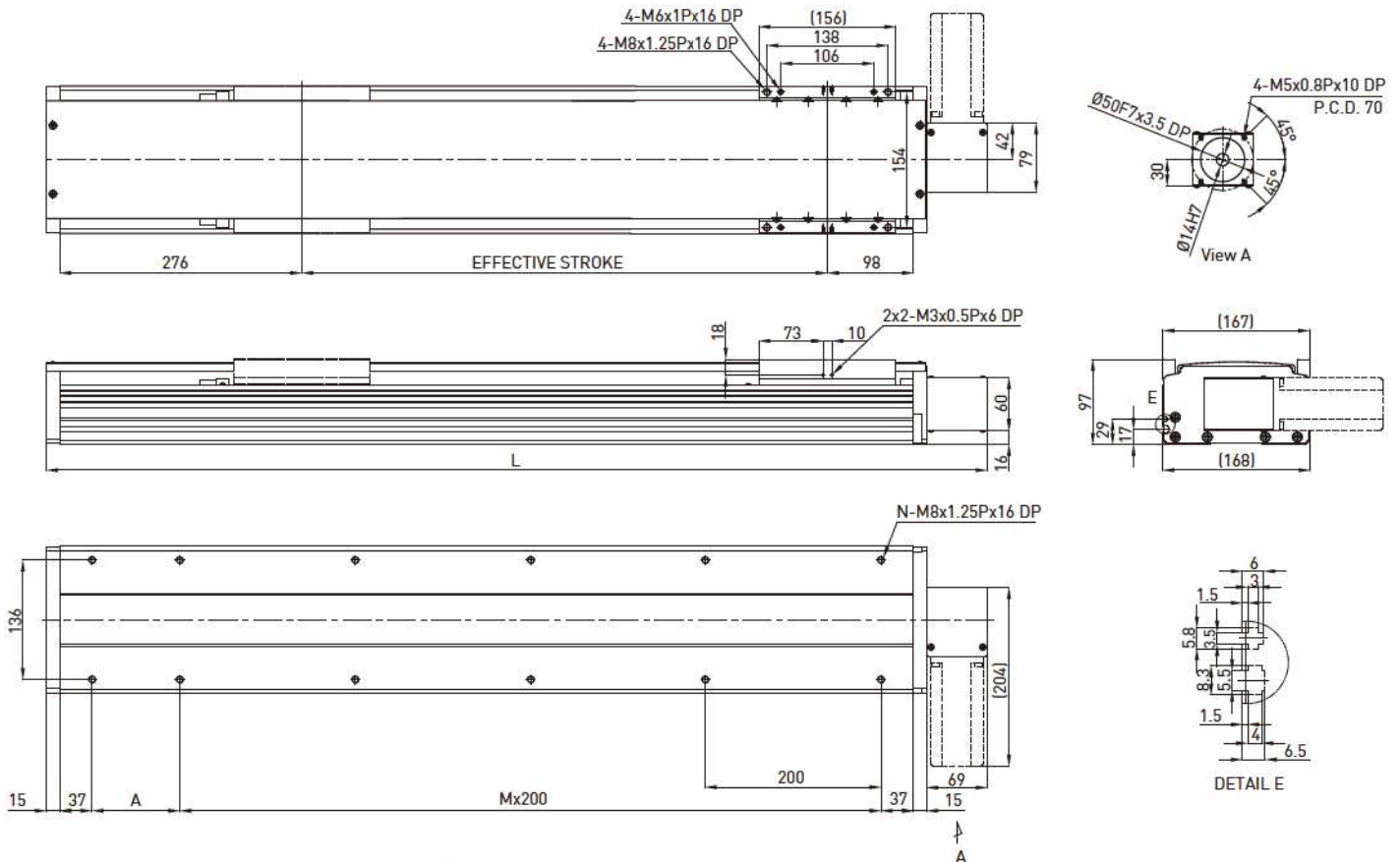

Effective stroke (mm)	L	A	M	N	Weight (kg)	AC motor output Drive	W	400													
200	673	100	2	8	14.74	Pulley Perimeter	mm	120													
400	873	100	3	10	17.88	Pulley RPM	RPM	900													
600	1073	100	4	12	21.13	Max linear speed	mm/sec	1800													
800	1273	100	5	14	24.37	Rated thrust	N	133													
1000	1473	100	6	16	27.52	Repeatability	mm	±0.1													
1200	1673	100	7	18	30.77	Effective stroke	mm	200-3000													
1400	1873	100	8	20	34.01	Max load (H)	kg	30													
1600	2073	100	9	22	37.07	<div style="display: flex; align-items: center;"> <div style="margin-right: 10px;"> <p>Rated dynamic load*</p> </div> </div> <table border="1" style="margin-left: 20px;"> <tr><td>Fyd</td><td>N</td><td>50</td></tr> <tr><td>Fzd</td><td>N</td><td>300</td></tr> <tr><td>Mxd</td><td>N-m</td><td>115</td></tr> <tr><td>Myd</td><td>N-m</td><td>96</td></tr> <tr><td>Mzd</td><td>N-m</td><td>96</td></tr> </table>	Fyd	N	50	Fzd	N	300	Mxd	N-m	115	Myd	N-m	96	Mzd	N-m	96
Fyd	N	50																			
Fzd	N	300																			
Mxd	N-m	115																			
Myd	N-m	96																			
Mzd	N-m	96																			
1800	2273	100	10	24	40.3	<p>Permitted load condition**</p> $\frac{F_y}{F_{yd}} + \frac{F_z}{F_{zd}} + \frac{M_x}{M_{xd}} + \frac{M_y}{M_{yd}} + \frac{M_z}{M_{zd}} \leq 1$ <p>Fy, Fz, Mx, My, Mz are working loads</p>															
2000	2473	100	11	26	43.54																
2200	2673	100	12	28	46.68																
2400	2873	100	13	30	49.92																
2600	3073	100	14	32	53.07																
2800	3273	100	15	34	56.2																
3000	3473	100	16	36	59.44																

*The load condition is based on 10,000km operation.

**For horizontal applications only. If used in a special condition, please contact HIWIN.

Model Number for KA200

KA200	-25	P	-1250	A	F0	U	S1	M751
Model	Lead	Precision Grade	Effective Stroke	Slider Type	Motor Flange	Cover	Limit Switch	Motor
	10mm 25mm	C: Normal P: Precision		A: Standard	F0 : Direct	U: Without Cover None : Standard Cover	S1: OMRON SX671 S2: OMRON SX674 S3: Panasonic GX-F12A S4: Panasonic GX-F12A-P None: No Limit Switch	M75□ K75□ Motor specification: ref. catalog P.167 M:customer specified None:Without Motor

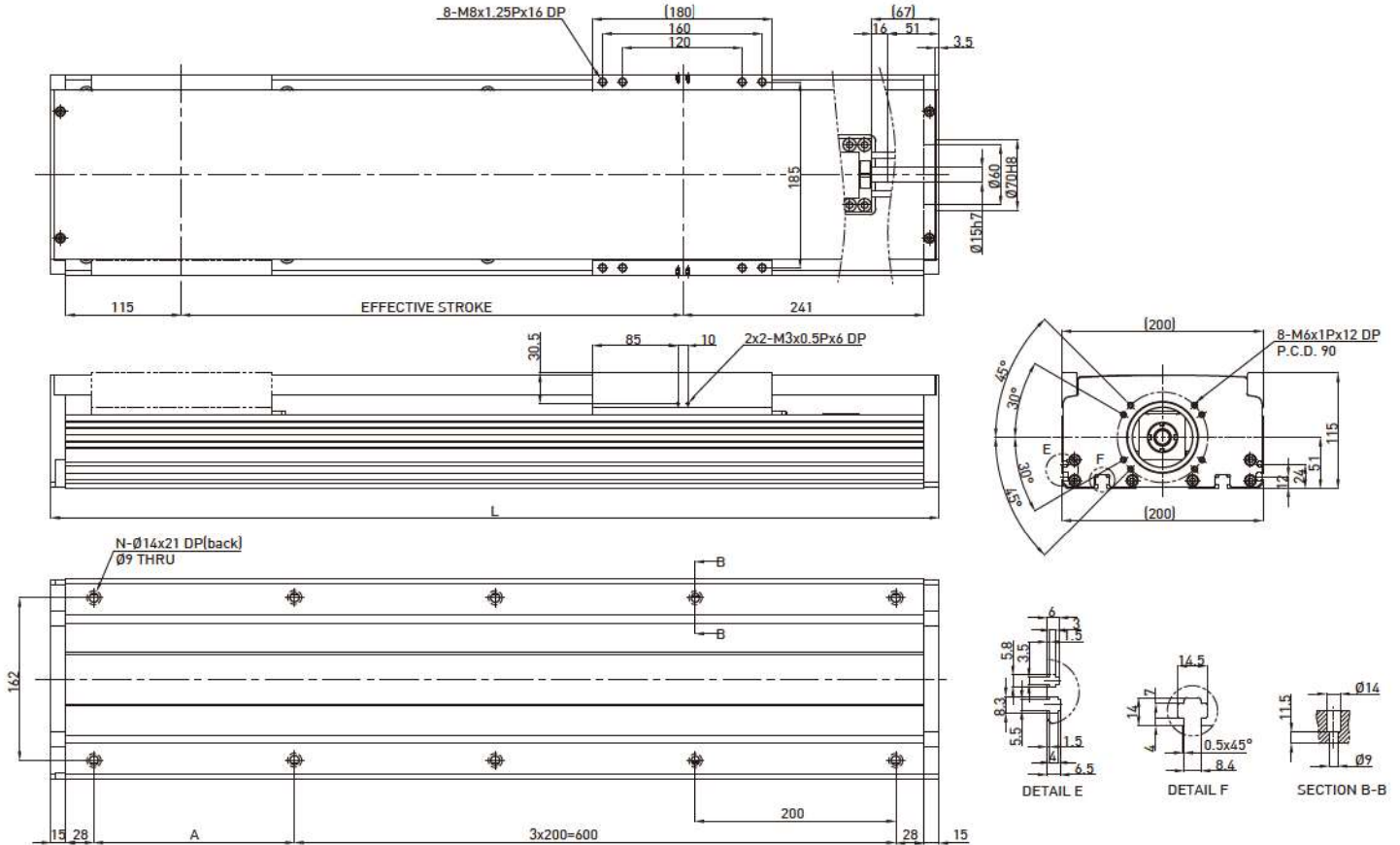

Effective stroke (mm)	L	A	M	N	Weight (kg)	AC motor output Drive	W	750																		
150	536	50	2	8	17.66	Lead	mm	10 25																		
200	586	100	2	8	18.99	Rated RPM	RPM	3000 3000																		
250	636	150	2	8	20.32	Max linear speed*	mm/sec	500 1250																		
300	686	200	2	8	21.65	Rated thrust	N	1050 420																		
350	736	50	3	10	22.98	Repeatability	mm	±0.02																		
400	786	100	3	10	24.31	Effective stroke	mm	150-1250																		
450	836	150	3	10	25.64	Max load (H)	kg	150 85																		
500	886	200	3	10	26.97	Rated dynamic load** <table border="1"> <tr><td>Fyd</td><td>N</td><td>50</td><td>50</td></tr> <tr><td>Fzd</td><td>N</td><td>1500</td><td>850</td></tr> <tr><td>Mxd</td><td>N-m</td><td>180</td><td>185</td></tr> <tr><td>Myd</td><td>N-m</td><td>145</td><td>155</td></tr> <tr><td>Mzd</td><td>N-m</td><td>145</td><td>155</td></tr> </table>	Fyd	N	50	50	Fzd	N	1500	850	Mxd	N-m	180	185	Myd	N-m	145	155	Mzd	N-m	145	155
Fyd	N	50	50																							
Fzd	N	1500	850																							
Mxd	N-m	180	185																							
Myd	N-m	145	155																							
Mzd	N-m	145	155																							
550	936	50	4	12	28.3		Permitted load condition*** $\frac{F_y}{F_{yd}} + \frac{F_z}{F_{zd}} + \frac{M_x}{M_{xd}} + \frac{M_y}{M_{yd}} + \frac{M_z}{M_{zd}} \leq 1$ Fy, Fz, Mx, My, Mz are working loads																			
600	986	100	4	12	29.63																					
650	1036	150	4	12	30.96																					
700	1086	200	4	12	32.29																					
750	1136	50	5	14	33.62																					
800	1186	100	5	14	34.95																					
850	1236	150	5	14	36.28																					
900	1286	200	5	14	37.61																					
950	1336	50	6	16	38.94																					
1000	1386	100	6	16	40.27																					
1050	1436	150	6	16	41.61																					
1100	1486	200	6	16	42.93																					
1150	1536	50	7	18	44.26																					
1200	1586	100	7	18	45.59																					
1250	1636	150	7	18	46.92																					

* Vibration might occur when the effective stroke is longer than 800mm.
 The maximum speed should be decreased by 15% for every 100mm of increased stroke.
 **The load condition is based on 10,000km operation.
 ***If used in a special condition, please contact HIWIN.

Model Number for KA200-FD

KA200	-25	P	-1250	A	FD	U	S1	M751
Model	Lead	Precision Grade	Effective Stroke	Slider Type	Motor Flange	Cover	Limit Switch	Motor
	10mm 25mm	C: Normal P: Precision		A: Standard	FD: Bottom	U: Without Cover None : Standard Cover	S1: OMRON SX671 S2: OMRON SX674 S3: Panasonic GX-F12A S4: Panasonic GX-F12A-P None: No Limit Switch	M75□ K75□ Motor specification: ref. catalog P.167 M: customer specified None: Without Motor

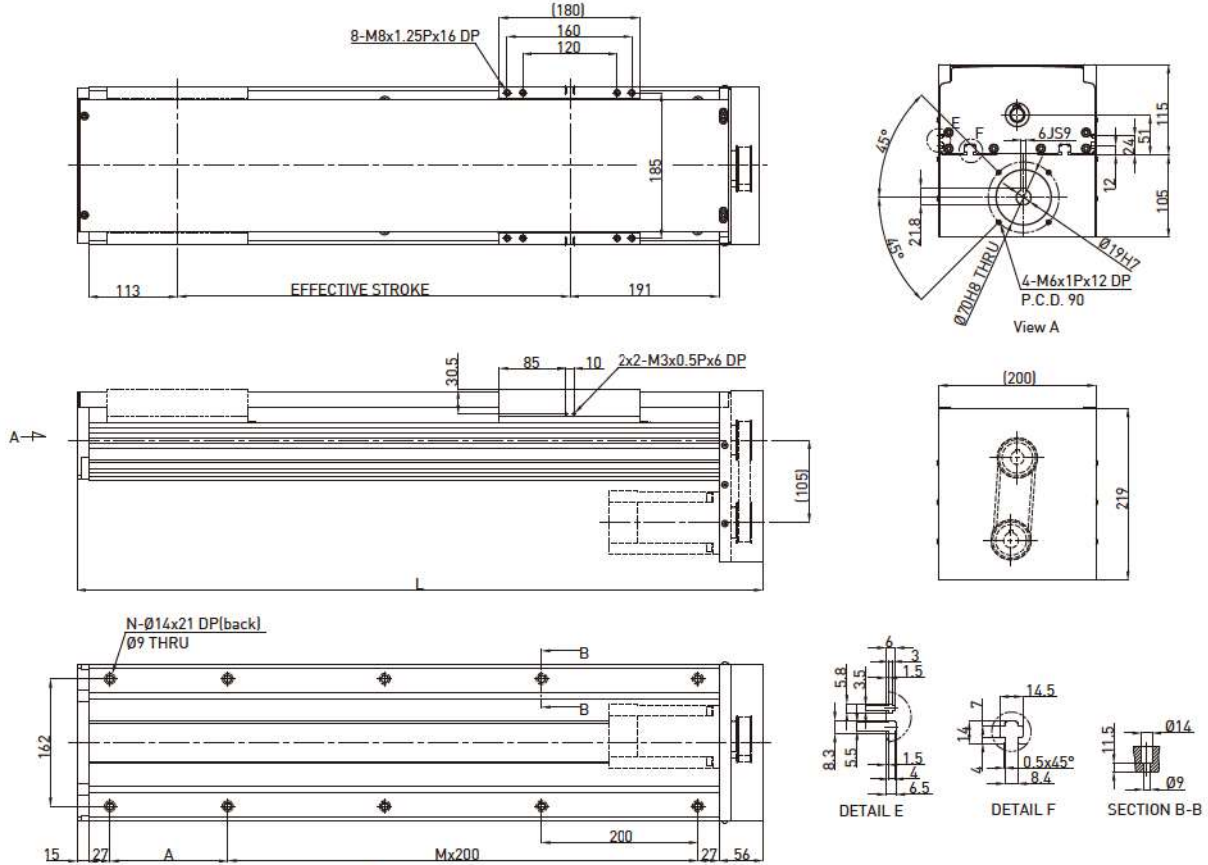

Effective stroke (mm)	L	A	M	N	Weight (kg)	AC motor output Drive	W	750	
150	525	200	1	6	18.46	Lead	mm	10 25	
200	575	50	2	8	19.79	Rated RPM	RPM	3000 3000	
250	625	100	2	8	21.12	Max linear speed*	mm/sec	500 1250	
300	675	150	2	8	22.45	Rated thrust	N	1050 420	
350	725	200	2	8	23.78	Repeatability	mm	±0.02	
400	775	50	3	10	25.11	Effective stroke	mm	150-1250	
450	825	100	3	10	26.44	Max load (H)	kg	150 85	
500	875	150	3	10	27.77		Fyd	N	50 50
550	925	200	3	10	29.1		Fzd	N	1500 850
600	975	50	4	12	30.43		Mxd	N-m	180 185
650	1025	100	4	12	31.76		Myd	N-m	145 155
700	1075	150	4	12	33.09		Mzd	N-m	145 155
750	1125	200	4	12	34.42		$\frac{F_y}{F_yd} + \frac{F_z}{F_zd} + \frac{M_x}{M_xd} + \frac{M_y}{M_yd} + \frac{M_z}{M_zd} \leq 1$		
800	1175	50	5	14	35.75	Fy, Fz, Mx, My, Mz are working loads			
850	1225	100	5	14	37.08	Permitted load condition***			
900	1275	150	5	14	38.41	* Vibration might occur when the effective stroke is longer than 800mm. The maximum speed should be decreased by 15% for every 100mm of increased stroke.			
950	1325	200	5	14	39.74	**The load condition is based on 10,000km operation.			
1000	1375	50	6	16	41.07	***If used in a special condition, please contact HIWIN.			
1050	1425	100	6	16	42.41				
1100	1475	150	6	16	43.73				
1150	1525	200	6	16	45.06				
1200	1575	50	7	18	46.39				
1250	1625	100	7	18	47.72				

Model Number for KA200-FI

KA200	-25	P	-1250	A	FI	U	S1	M751
Model	Lead	Precision Grade	Effective Stroke	Slider Type	Motor Flange	Cover	Limit Switch	Motor
	10mm 25mm	C: Normal P: Precision		A: Standard	FI: Internal	U: Without Cover None : Standard Cover	S1: OMRON SX671 S2: OMRON SX674 S3: Panasonic GX-F12A S4: Panasonic GX-F12A-P None: No Limit Switch	M75□ K75□ Motor specification: ref. catalog P.167 M:customer specified None:Without Motor

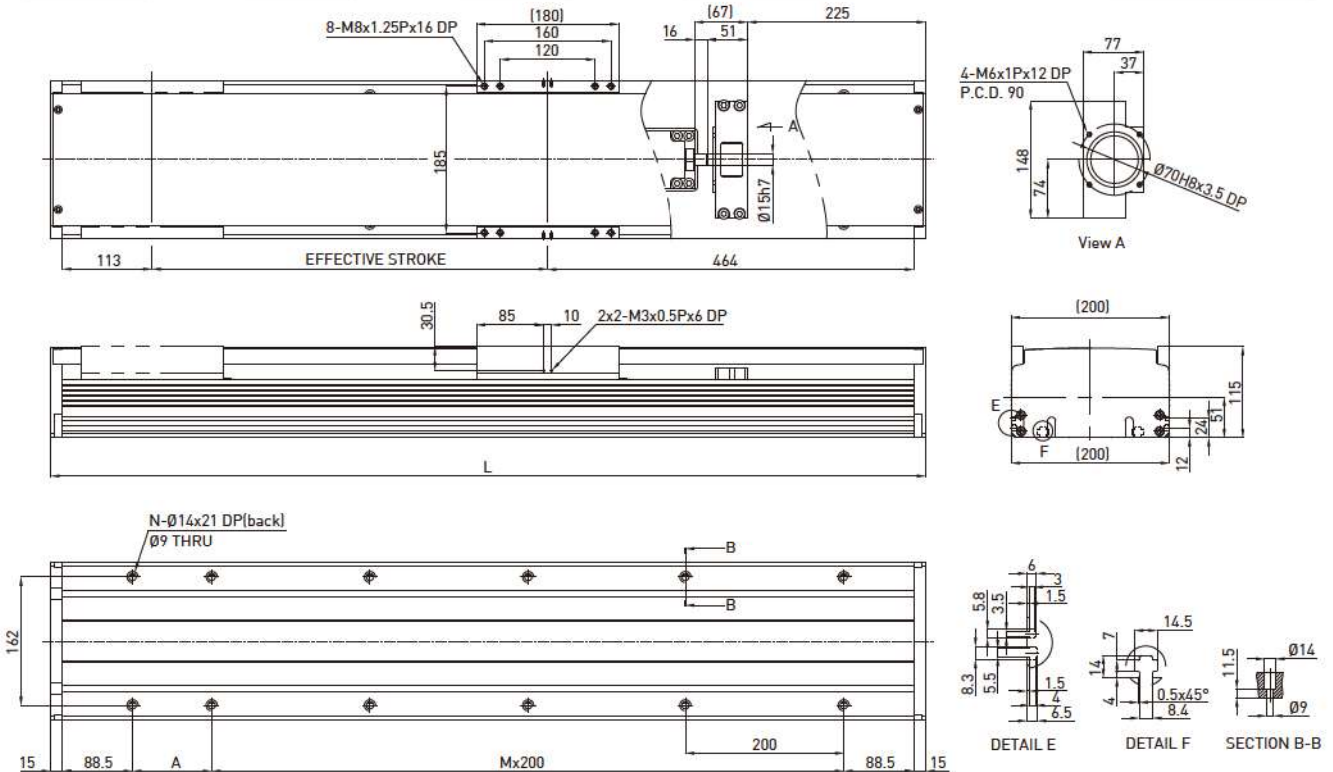

Effective stroke (mm)	L	A	M	N	Weight (kg)	AC motor output Drive	W	750																		
150	757	150	2	8	19.83	Lead	mm	10 25																		
200	807	200	2	8	21.32	Rated RPM	RPM	3000 3000																		
250	857	50	3	10	22.82	Max linear speed*	mm/sec	500 1250																		
300	907	100	3	10	24.31	Rated thrust	N	1050 420																		
350	957	150	3	10	25.81	Repeatability	mm	±0.02																		
400	1007	200	3	10	27.3	Effective stroke	mm	150~1250																		
450	1057	50	4	12	28.79	Max load (H)	kg	150 85																		
500	1107	100	4	12	30.29	<div style="display: flex; align-items: center;"> <div style="margin-right: 20px;"> <p>Rated dynamic load**</p> </div> <div style="text-align: center;"> </div> </div> <table border="1" style="margin-left: 20px;"> <tr><td>Fyd</td><td>N</td><td>50</td><td>50</td></tr> <tr><td>Fzd</td><td>N</td><td>1500</td><td>850</td></tr> <tr><td>Mxd</td><td>N-m</td><td>180</td><td>185</td></tr> <tr><td>Myd</td><td>N-m</td><td>145</td><td>155</td></tr> <tr><td>Mzd</td><td>N-m</td><td>145</td><td>155</td></tr> </table>	Fyd	N	50	50	Fzd	N	1500	850	Mxd	N-m	180	185	Myd	N-m	145	155	Mzd	N-m	145	155
Fyd	N	50	50																							
Fzd	N	1500	850																							
Mxd	N-m	180	185																							
Myd	N-m	145	155																							
Mzd	N-m	145	155																							
550	1157	150	4	12	31.78		<p>Permitted load condition***</p> $\frac{F_y}{F_{yd}} + \frac{F_z}{F_{zd}} + \frac{M_x}{M_{xd}} + \frac{M_y}{M_{yd}} + \frac{M_z}{M_{zd}} \leq 1$ <p>Fy, Fz, Mx, My, Mz are working loads</p>																			
600	1207	200	4	12	33.27																					
650	1257	50	5	14	34.77																					
700	1307	100	5	14	36.26																					
750	1357	150	5	14	37.76																					
800	1407	200	5	14	39.25																					
850	1457	50	6	16	40.74																					
900	1507	100	6	16	42.24																					
950	1557	150	6	16	43.73																					
1000	1607	200	6	16	45.22																					
1050	1657	50	7	18	46.73																					
1100	1707	100	7	18	48.21																					
1150	1757	150	7	18	49.7																					
1200	1807	200	7	18	51.2																					
1250	1857	50	8	19	52.69																					

* Vibration might occur when the effective stroke is longer than 800mm.
 The maximum speed should be decreased by 15% for every 100mm of increased stroke.
 **The load condition is based on 10,000km operation.
 ***If used in a special condition, please contact HIWIN.

Model Number for KA200-FL

KA200	-25	P	-1250	A	FL	U	S1	M751
Model	Lead	Precision Grade	Effective Stroke	Slider Type	Motor Flange	Cover	Limit Switch	Motor
	10mm 25mm	C: Normal P: Precision		A: Standard	FL: Left	U: Without Cover None : Standard Cover	S1: OMRON SX671 S2: OMRON SX674 S3: Panasonic GX-F12A S4: Panasonic GX-F12A-P None: No Limit Switch	M75□ K75□ Motor specification: ref. catalog P.167 M:customer specified None:Without Motor

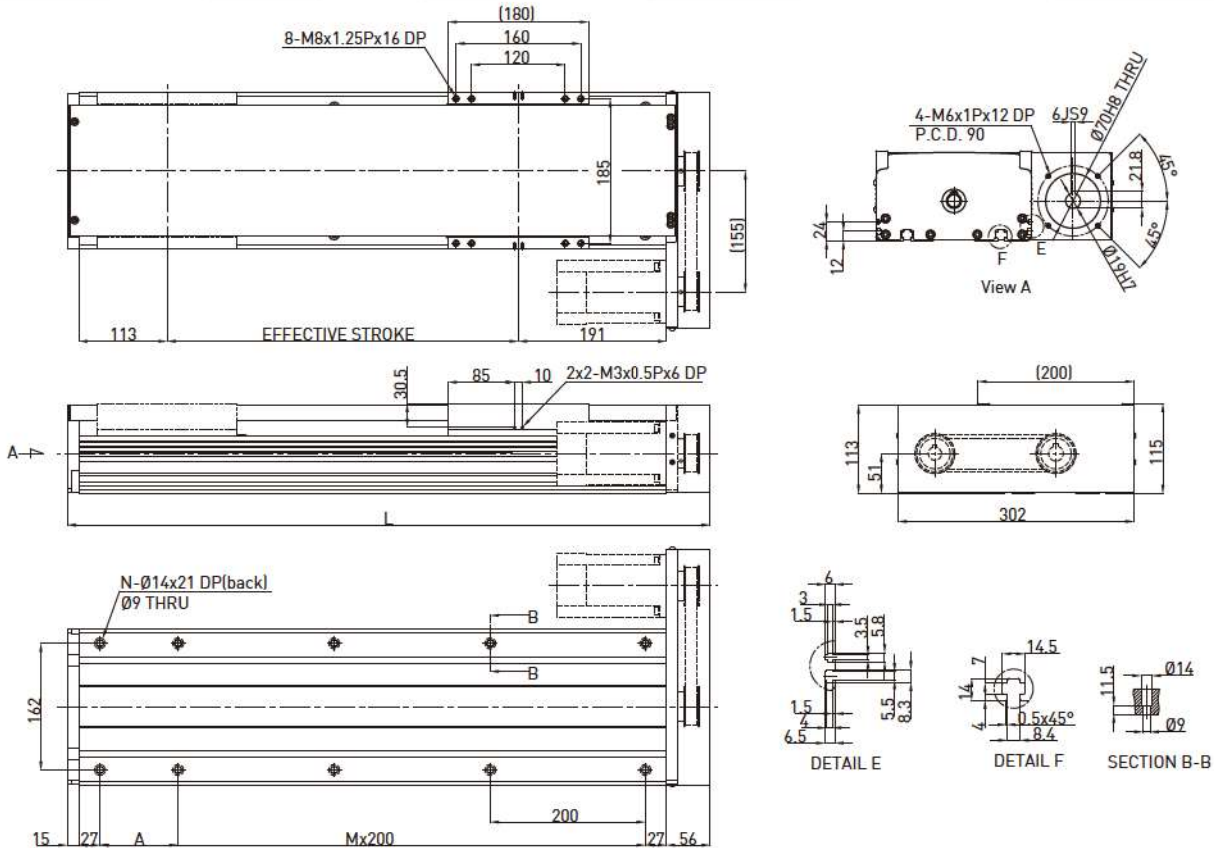

Effective stroke (mm)	L	A	M	N	Weight (kg)	AC motor output	W	750	
150	525	200	1	6	18.46	Drive		Ballscrew C7(normal)	
200	575	50	2	8	19.79	Lead	mm	10 25	
250	625	100	2	8	21.12	Rated RPM	RPM	3000 3000	
300	675	150	2	8	22.45	Max linear speed*	mm/sec	500 1250	
350	725	200	2	8	23.78	Rated thrust	N	1050 420	
400	775	50	3	10	25.11	Repeatability	mm	±0.02	
450	825	100	3	10	26.44	Effective stroke	mm	150~1250	
500	875	150	3	10	27.77	Max load (H)	kg	150 85	
550	925	200	3	10	29.1	Rated dynamic load**	F _{yd}	N	50 50
600	975	50	4	12	30.43		F _{zd}	N	1500 850
650	1025	100	4	12	31.76		M _{xd}	N-m	180 185
700	1075	150	4	12	33.09		M _{yd}	N-m	145 155
750	1125	200	4	12	34.42		M _{zd}	N-m	145 155
800	1175	50	5	14	35.75		Permitted load condition*** $\frac{F_y}{F_{yd}} + \frac{F_z}{F_{zd}} + \frac{M_x}{M_{xd}} + \frac{M_y}{M_{yd}} + \frac{M_z}{M_{zd}} \leq 1$ F _y , F _z , M _x , M _y , M _z are working loads		
850	1225	100	5	14	37.08				
900	1275	150	5	14	38.41				
950	1325	200	5	14	39.74				
1000	1375	50	6	16	41.07				
1050	1425	100	6	16	42.41	* Vibration might occur when the effective stroke is longer than 800mm. The maximum speed should be decreased by 15% for every 100mm of increased stroke. **The load condition is based on 10,000km operation. ***If used in a special condition, please contact HIWIN.			
1100	1475	150	6	16	43.73				
1150	1525	200	6	16	45.06				
1200	1575	50	7	18	46.39				
1250	1625	100	7	18	47.72				

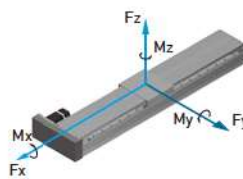

Model Number for KA200-FR

KA200	-25	P	-1250	A	FR	U	S1	M751
Model	Lead	Precision Grade	Effective Stroke	Slider Type	Motor Flange	Cover	Limit Switch	Motor
	10mm 25mm	C: Normal P: Precision		A: Standard	FR: Right	U: Without Cover None : Standard Cover	S1: OMRON SX671 S2: OMRON SX674 S3: Panasonic GX-F12A S4: Panasonic GX-F12A-P None: No Limit Switch	M75□ K75□ Motor specification: ref. catalog P.167 M:customer specified None:Without Motor

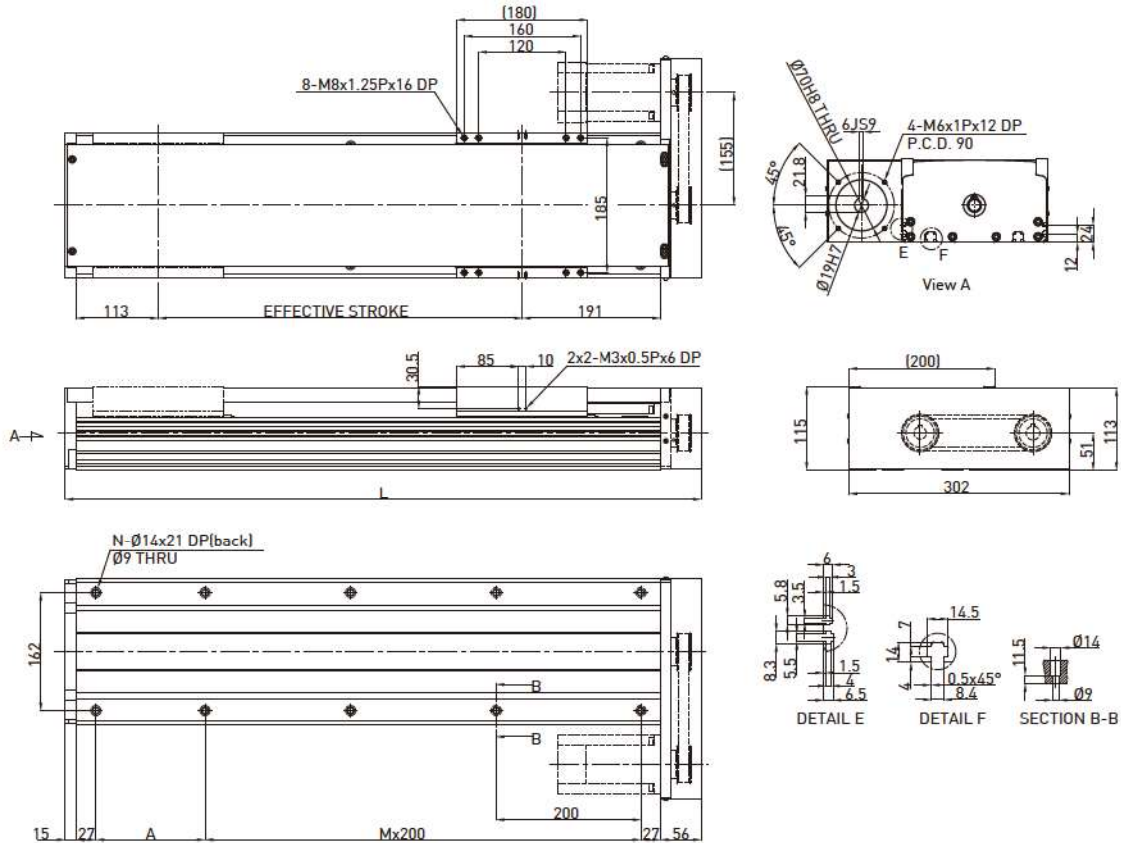

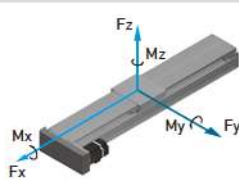
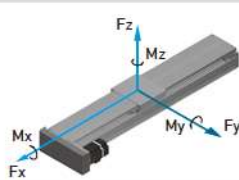
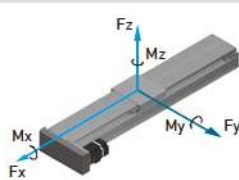
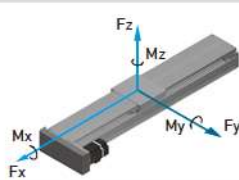
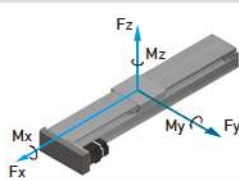
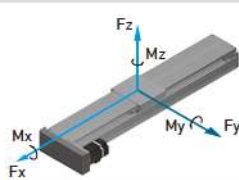
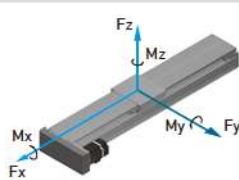
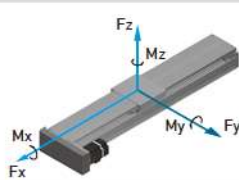
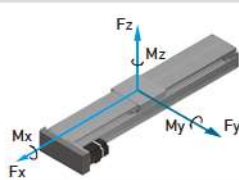
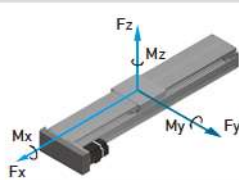
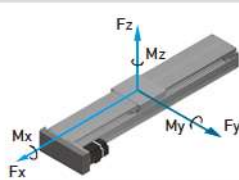
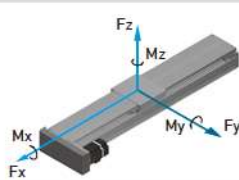
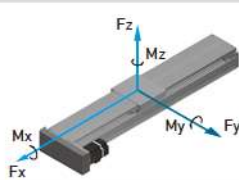
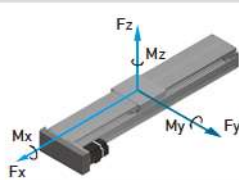
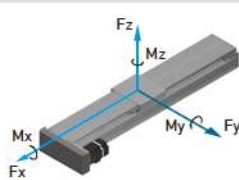
Effective stroke (mm)	L	A	M	N	Weight (kg)	AC motor output	W	750																			
150	525	200	1	6	18.46	Drive	Ball screw C7(normal)																				
200	575	50	2	8	19.79	Lead	mm	10 25																			
250	625	100	2	8	21.12	Rated RPM	RPM	3000 3000																			
300	675	150	2	8	22.45	Max linear speed*	mm/sec	500 1250																			
350	725	200	2	8	23.78	Rated thrust	N	1050 420																			
400	775	50	3	10	25.11	Repeatability	mm	±0.02																			
450	825	100	3	10	26.44	Effective stroke	mm	150~1250																			
500	875	150	3	10	27.77	Max load (H)	kg	150 85																			
550	925	200	3	10	29.1	<div style="display: flex; align-items: center;">  <table border="1" style="margin-left: 20px;"> <tr><td>Fyd</td><td>N</td><td>50</td><td>50</td></tr> <tr><td>Fzd</td><td>N</td><td>1500</td><td>850</td></tr> <tr><td>Mxd</td><td>N-m</td><td>180</td><td>185</td></tr> <tr><td>Myd</td><td>N-m</td><td>145</td><td>155</td></tr> <tr><td>Mzd</td><td>N-m</td><td>145</td><td>155</td></tr> </table> </div>	Fyd	N	50	50	Fzd	N	1500	850	Mxd	N-m	180	185	Myd	N-m	145	155	Mzd	N-m	145	155	
Fyd	N	50	50																								
Fzd	N	1500	850																								
Mxd	N-m	180	185																								
Myd	N-m	145	155																								
Mzd	N-m	145	155																								
600	975	50	4	12	30.43		<div style="display: flex; align-items: center;">  <table border="1" style="margin-left: 20px;"> <tr><td>Fyd</td><td>N</td><td>50</td><td>50</td></tr> <tr><td>Fzd</td><td>N</td><td>1500</td><td>850</td></tr> <tr><td>Mxd</td><td>N-m</td><td>180</td><td>185</td></tr> <tr><td>Myd</td><td>N-m</td><td>145</td><td>155</td></tr> <tr><td>Mzd</td><td>N-m</td><td>145</td><td>155</td></tr> </table> </div>	Fyd	N	50	50	Fzd	N	1500	850	Mxd	N-m	180	185	Myd	N-m	145	155	Mzd	N-m	145	155
Fyd	N	50	50																								
Fzd	N	1500	850																								
Mxd	N-m	180	185																								
Myd	N-m	145	155																								
Mzd	N-m	145	155																								
650	1025	100	4	12	31.76	<div style="display: flex; align-items: center;">  <table border="1" style="margin-left: 20px;"> <tr><td>Fyd</td><td>N</td><td>50</td><td>50</td></tr> <tr><td>Fzd</td><td>N</td><td>1500</td><td>850</td></tr> <tr><td>Mxd</td><td>N-m</td><td>180</td><td>185</td></tr> <tr><td>Myd</td><td>N-m</td><td>145</td><td>155</td></tr> <tr><td>Mzd</td><td>N-m</td><td>145</td><td>155</td></tr> </table> </div>		Fyd	N	50	50	Fzd	N	1500	850	Mxd	N-m	180	185	Myd	N-m	145	155	Mzd	N-m	145	155
Fyd	N	50	50																								
Fzd	N	1500	850																								
Mxd	N-m	180	185																								
Myd	N-m	145	155																								
Mzd	N-m	145	155																								
700	1075	150	4	12	33.09		<div style="display: flex; align-items: center;">  <table border="1" style="margin-left: 20px;"> <tr><td>Fyd</td><td>N</td><td>50</td><td>50</td></tr> <tr><td>Fzd</td><td>N</td><td>1500</td><td>850</td></tr> <tr><td>Mxd</td><td>N-m</td><td>180</td><td>185</td></tr> <tr><td>Myd</td><td>N-m</td><td>145</td><td>155</td></tr> <tr><td>Mzd</td><td>N-m</td><td>145</td><td>155</td></tr> </table> </div>	Fyd	N	50	50	Fzd	N	1500	850	Mxd	N-m	180	185	Myd	N-m	145	155	Mzd	N-m	145	155
Fyd	N	50	50																								
Fzd	N	1500	850																								
Mxd	N-m	180	185																								
Myd	N-m	145	155																								
Mzd	N-m	145	155																								
750	1125	200	4	12	34.42	<div style="display: flex; align-items: center;">  <table border="1" style="margin-left: 20px;"> <tr><td>Fyd</td><td>N</td><td>50</td><td>50</td></tr> <tr><td>Fzd</td><td>N</td><td>1500</td><td>850</td></tr> <tr><td>Mxd</td><td>N-m</td><td>180</td><td>185</td></tr> <tr><td>Myd</td><td>N-m</td><td>145</td><td>155</td></tr> <tr><td>Mzd</td><td>N-m</td><td>145</td><td>155</td></tr> </table> </div>		Fyd	N	50	50	Fzd	N	1500	850	Mxd	N-m	180	185	Myd	N-m	145	155	Mzd	N-m	145	155
Fyd	N	50	50																								
Fzd	N	1500	850																								
Mxd	N-m	180	185																								
Myd	N-m	145	155																								
Mzd	N-m	145	155																								
800	1175	50	5	14	35.75		<div style="display: flex; align-items: center;">  <table border="1" style="margin-left: 20px;"> <tr><td>Fyd</td><td>N</td><td>50</td><td>50</td></tr> <tr><td>Fzd</td><td>N</td><td>1500</td><td>850</td></tr> <tr><td>Mxd</td><td>N-m</td><td>180</td><td>185</td></tr> <tr><td>Myd</td><td>N-m</td><td>145</td><td>155</td></tr> <tr><td>Mzd</td><td>N-m</td><td>145</td><td>155</td></tr> </table> </div>	Fyd	N	50	50	Fzd	N	1500	850	Mxd	N-m	180	185	Myd	N-m	145	155	Mzd	N-m	145	155
Fyd	N	50	50																								
Fzd	N	1500	850																								
Mxd	N-m	180	185																								
Myd	N-m	145	155																								
Mzd	N-m	145	155																								
850	1225	100	5	14	37.08	<div style="display: flex; align-items: center;">  <table border="1" style="margin-left: 20px;"> <tr><td>Fyd</td><td>N</td><td>50</td><td>50</td></tr> <tr><td>Fzd</td><td>N</td><td>1500</td><td>850</td></tr> <tr><td>Mxd</td><td>N-m</td><td>180</td><td>185</td></tr> <tr><td>Myd</td><td>N-m</td><td>145</td><td>155</td></tr> <tr><td>Mzd</td><td>N-m</td><td>145</td><td>155</td></tr> </table> </div>		Fyd	N	50	50	Fzd	N	1500	850	Mxd	N-m	180	185	Myd	N-m	145	155	Mzd	N-m	145	155
Fyd	N	50	50																								
Fzd	N	1500	850																								
Mxd	N-m	180	185																								
Myd	N-m	145	155																								
Mzd	N-m	145	155																								
900	1275	150	5	14	38.41		<div style="display: flex; align-items: center;">  <table border="1" style="margin-left: 20px;"> <tr><td>Fyd</td><td>N</td><td>50</td><td>50</td></tr> <tr><td>Fzd</td><td>N</td><td>1500</td><td>850</td></tr> <tr><td>Mxd</td><td>N-m</td><td>180</td><td>185</td></tr> <tr><td>Myd</td><td>N-m</td><td>145</td><td>155</td></tr> <tr><td>Mzd</td><td>N-m</td><td>145</td><td>155</td></tr> </table> </div>	Fyd	N	50	50	Fzd	N	1500	850	Mxd	N-m	180	185	Myd	N-m	145	155	Mzd	N-m	145	155
Fyd	N	50	50																								
Fzd	N	1500	850																								
Mxd	N-m	180	185																								
Myd	N-m	145	155																								
Mzd	N-m	145	155																								
950	1325	200	5	14	39.74	<div style="display: flex; align-items: center;">  <table border="1" style="margin-left: 20px;"> <tr><td>Fyd</td><td>N</td><td>50</td><td>50</td></tr> <tr><td>Fzd</td><td>N</td><td>1500</td><td>850</td></tr> <tr><td>Mxd</td><td>N-m</td><td>180</td><td>185</td></tr> <tr><td>Myd</td><td>N-m</td><td>145</td><td>155</td></tr> <tr><td>Mzd</td><td>N-m</td><td>145</td><td>155</td></tr> </table> </div>		Fyd	N	50	50	Fzd	N	1500	850	Mxd	N-m	180	185	Myd	N-m	145	155	Mzd	N-m	145	155
Fyd	N	50	50																								
Fzd	N	1500	850																								
Mxd	N-m	180	185																								
Myd	N-m	145	155																								
Mzd	N-m	145	155																								
1000	1375	50	6	16	41.07		<div style="display: flex; align-items: center;">  <table border="1" style="margin-left: 20px;"> <tr><td>Fyd</td><td>N</td><td>50</td><td>50</td></tr> <tr><td>Fzd</td><td>N</td><td>1500</td><td>850</td></tr> <tr><td>Mxd</td><td>N-m</td><td>180</td><td>185</td></tr> <tr><td>Myd</td><td>N-m</td><td>145</td><td>155</td></tr> <tr><td>Mzd</td><td>N-m</td><td>145</td><td>155</td></tr> </table> </div>	Fyd	N	50	50	Fzd	N	1500	850	Mxd	N-m	180	185	Myd	N-m	145	155	Mzd	N-m	145	155
Fyd	N	50	50																								
Fzd	N	1500	850																								
Mxd	N-m	180	185																								
Myd	N-m	145	155																								
Mzd	N-m	145	155																								
1050	1425	100	6	16	42.41	<div style="display: flex; align-items: center;">  <table border="1" style="margin-left: 20px;"> <tr><td>Fyd</td><td>N</td><td>50</td><td>50</td></tr> <tr><td>Fzd</td><td>N</td><td>1500</td><td>850</td></tr> <tr><td>Mxd</td><td>N-m</td><td>180</td><td>185</td></tr> <tr><td>Myd</td><td>N-m</td><td>145</td><td>155</td></tr> <tr><td>Mzd</td><td>N-m</td><td>145</td><td>155</td></tr> </table> </div>		Fyd	N	50	50	Fzd	N	1500	850	Mxd	N-m	180	185	Myd	N-m	145	155	Mzd	N-m	145	155
Fyd	N	50	50																								
Fzd	N	1500	850																								
Mxd	N-m	180	185																								
Myd	N-m	145	155																								
Mzd	N-m	145	155																								
1100	1475	150	6	16	43.73		<div style="display: flex; align-items: center;">  <table border="1" style="margin-left: 20px;"> <tr><td>Fyd</td><td>N</td><td>50</td><td>50</td></tr> <tr><td>Fzd</td><td>N</td><td>1500</td><td>850</td></tr> <tr><td>Mxd</td><td>N-m</td><td>180</td><td>185</td></tr> <tr><td>Myd</td><td>N-m</td><td>145</td><td>155</td></tr> <tr><td>Mzd</td><td>N-m</td><td>145</td><td>155</td></tr> </table> </div>	Fyd	N	50	50	Fzd	N	1500	850	Mxd	N-m	180	185	Myd	N-m	145	155	Mzd	N-m	145	155
Fyd	N	50	50																								
Fzd	N	1500	850																								
Mxd	N-m	180	185																								
Myd	N-m	145	155																								
Mzd	N-m	145	155																								
1150	1525	200	6	16	45.06	<div style="display: flex; align-items: center;">  <table border="1" style="margin-left: 20px;"> <tr><td>Fyd</td><td>N</td><td>50</td><td>50</td></tr> <tr><td>Fzd</td><td>N</td><td>1500</td><td>850</td></tr> <tr><td>Mxd</td><td>N-m</td><td>180</td><td>185</td></tr> <tr><td>Myd</td><td>N-m</td><td>145</td><td>155</td></tr> <tr><td>Mzd</td><td>N-m</td><td>145</td><td>155</td></tr> </table> </div>		Fyd	N	50	50	Fzd	N	1500	850	Mxd	N-m	180	185	Myd	N-m	145	155	Mzd	N-m	145	155
Fyd	N	50	50																								
Fzd	N	1500	850																								
Mxd	N-m	180	185																								
Myd	N-m	145	155																								
Mzd	N-m	145	155																								
1200	1575	50	7	18	46.39		<div style="display: flex; align-items: center;">  <table border="1" style="margin-left: 20px;"> <tr><td>Fyd</td><td>N</td><td>50</td><td>50</td></tr> <tr><td>Fzd</td><td>N</td><td>1500</td><td>850</td></tr> <tr><td>Mxd</td><td>N-m</td><td>180</td><td>185</td></tr> <tr><td>Myd</td><td>N-m</td><td>145</td><td>155</td></tr> <tr><td>Mzd</td><td>N-m</td><td>145</td><td>155</td></tr> </table> </div>	Fyd	N	50	50	Fzd	N	1500	850	Mxd	N-m	180	185	Myd	N-m	145	155	Mzd	N-m	145	155
Fyd	N	50	50																								
Fzd	N	1500	850																								
Mxd	N-m	180	185																								
Myd	N-m	145	155																								
Mzd	N-m	145	155																								
1250	1625	100	7	18	47.72	<div style="display: flex; align-items: center;">  <table border="1" style="margin-left: 20px;"> <tr><td>Fyd</td><td>N</td><td>50</td><td>50</td></tr> <tr><td>Fzd</td><td>N</td><td>1500</td><td>850</td></tr> <tr><td>Mxd</td><td>N-m</td><td>180</td><td>185</td></tr> <tr><td>Myd</td><td>N-m</td><td>145</td><td>155</td></tr> <tr><td>Mzd</td><td>N-m</td><td>145</td><td>155</td></tr> </table> </div>		Fyd	N	50	50	Fzd	N	1500	850	Mxd	N-m	180	185	Myd	N-m	145	155	Mzd	N-m	145	155
Fyd	N	50	50																								
Fzd	N	1500	850																								
Mxd	N-m	180	185																								
Myd	N-m	145	155																								
Mzd	N-m	145	155																								
							Permitted load condition**	$\frac{F_y}{F_{yd}} + \frac{F_z}{F_{zd}} + \frac{M_x}{M_{xd}} + \frac{M_y}{M_{yd}} + \frac{M_z}{M_{zd}} \leq 1$ Fy, Fz, Mx, My, Mz are working loads																			

* Vibration might occur when the effective stroke is longer than 800mm.

The maximum speed should be decreased by 15% for every 100mm of increased stroke.

**The load condition is based on 10,000km operation.

***If used in a special condition, please contact HIWIN.

5.12 Motor Adaptor Flange List

Model	Flange Selection	Flange dimensions								
		a	b	c	d	e	f	g	h	i
KA100	F1	45	42	-	M3	7	30H8	28	-	-
KA136	F1	70	62	-	M4	10	50H8	46	-	-
	F2	46	62	-	M4	8	30H8	-	-	-
	F3	45	62	-	M3	8	30H8	-	-	-
	F4	90	80	-	M5	12	70H8	46	-	-
	F5	-	62	50	M4	8	36H8	46	-	-
	F6	-	62	47.14	M4	8	38.1H8	46	-	-
KA170	F1	90	80	-	M6	12	70H8	46	-	-
	F2	90	80	-	M5	12	70H8	46	-	-
	F3	-	82	70	M6	12	60H8	46	-	-
	F4	-	82	69.58	M6	12	73.06H8	46	-	-
KA200	F1	70	-	-	M5	12	70H8	60	73	92
	F2	90	-	-	M5	12	70H8	60	80	92

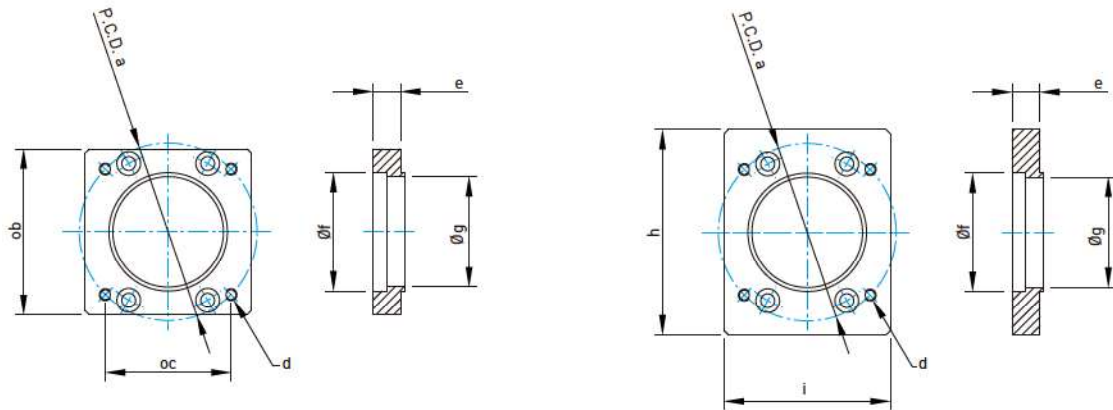

KA90

Motor Adaptor Flange F0

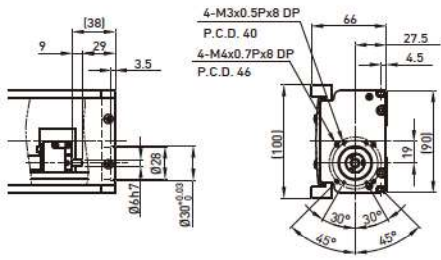

KA120

Motor Adaptor Flange F0

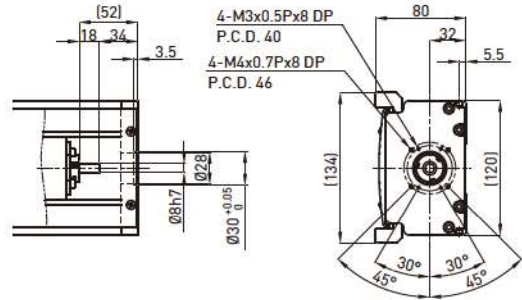

Motor Adaptor Flange F1

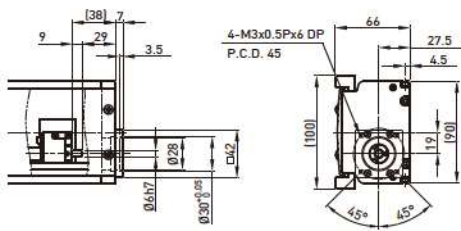

Motor Adaptor Flange F1

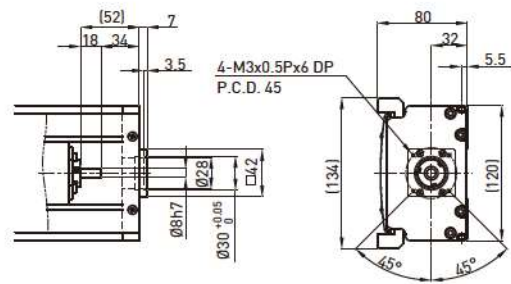

KA100

Motor Adaptor Flange F0

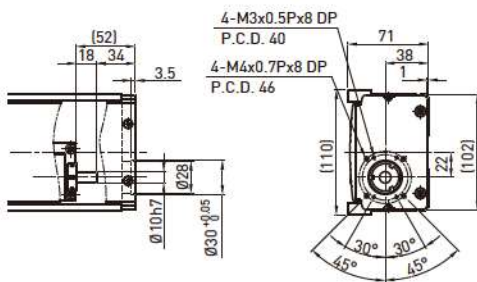

Motor Adaptor Flange F1

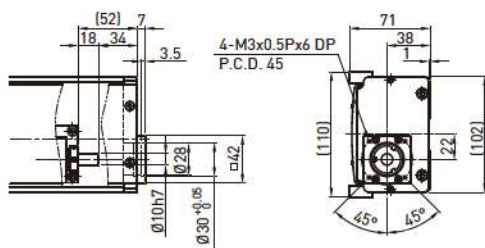

KA136

Motor Adaptor Flange F0

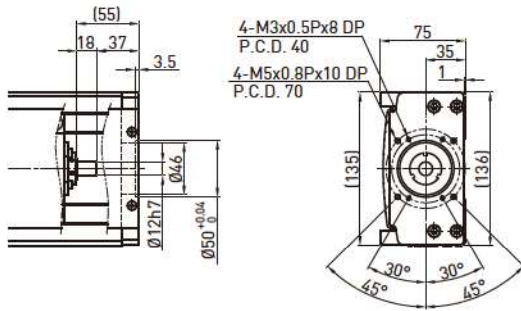

Motor Adaptor Flange F1

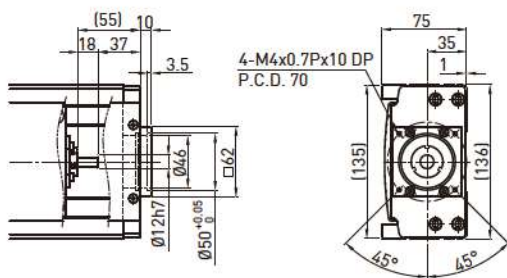

Motor Adaptor Flange F4

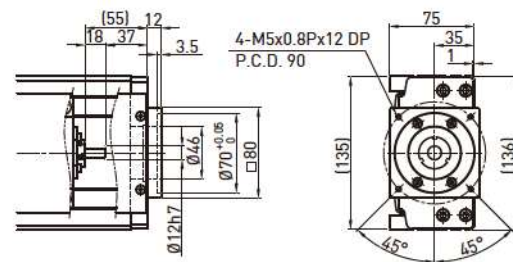

Motor Adaptor Flange F2

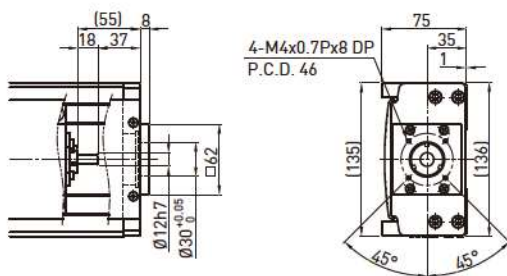

Motor Adaptor Flange F5

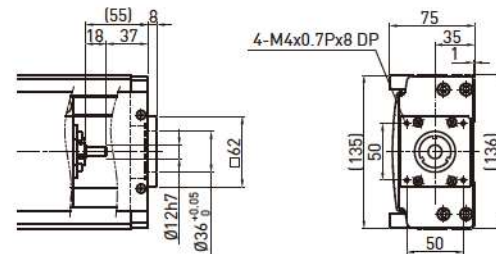

Motor Adaptor Flange F3

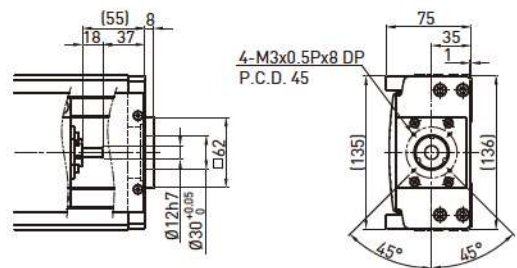

Motor Adaptor Flange F6

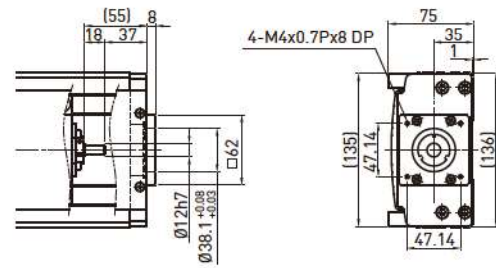

KA150

Motor Adaptor Flange F0

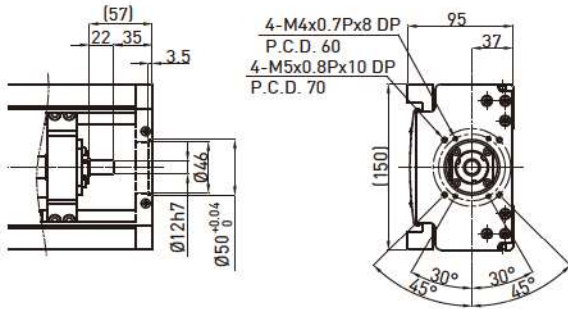

Motor Adaptor Flange F1

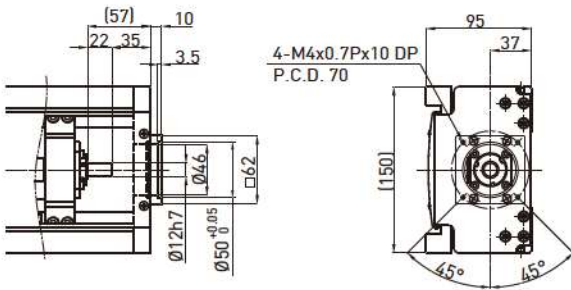

Motor Adaptor Flange F4

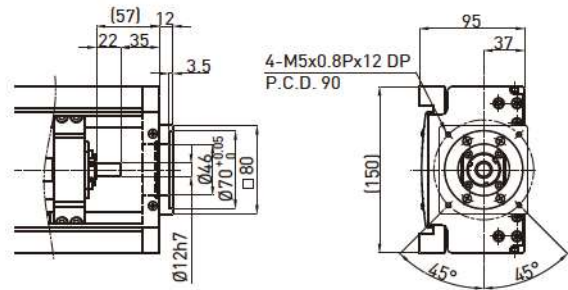

Motor Adaptor Flange F2

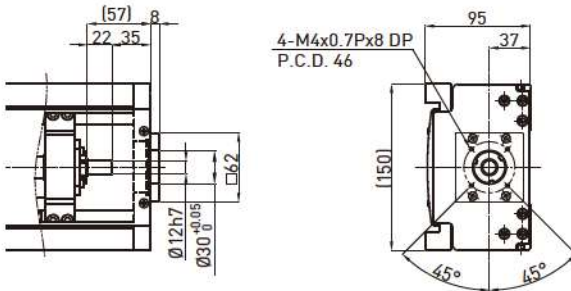

Motor Adaptor Flange F5

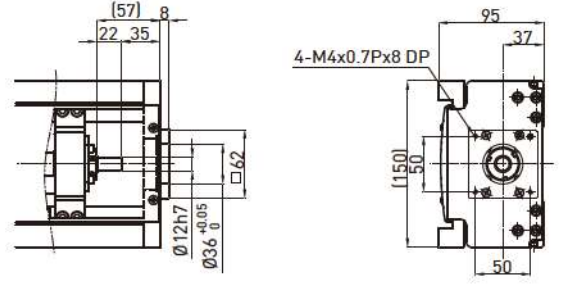

Motor Adaptor Flange F3

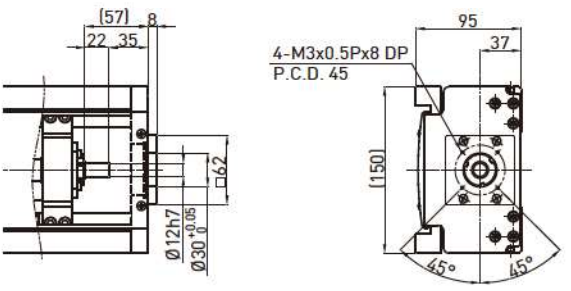

Motor Adaptor Flange F6

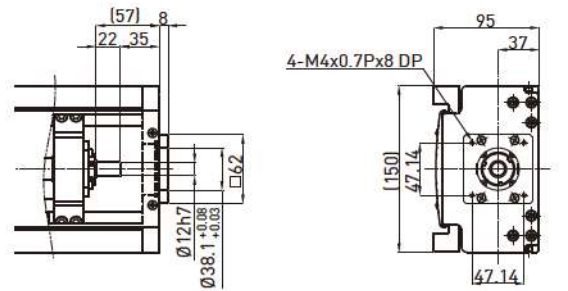

KA170

Motor Adaptor Flange F0

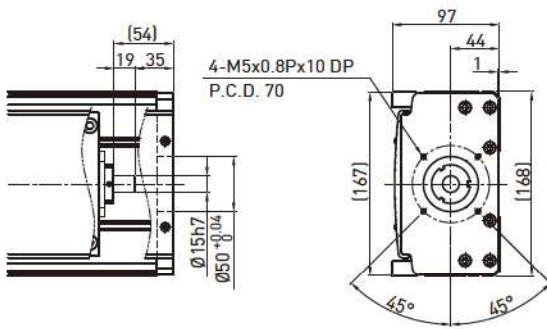

Motor Adaptor Flange F1

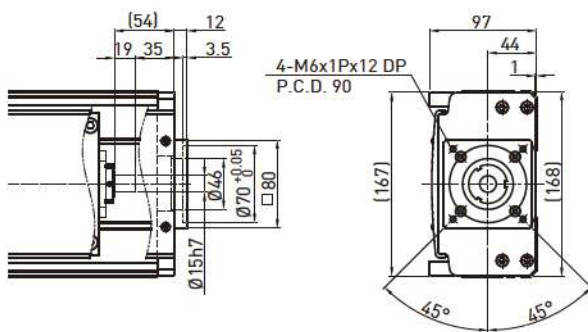

Motor Adaptor Flange F3

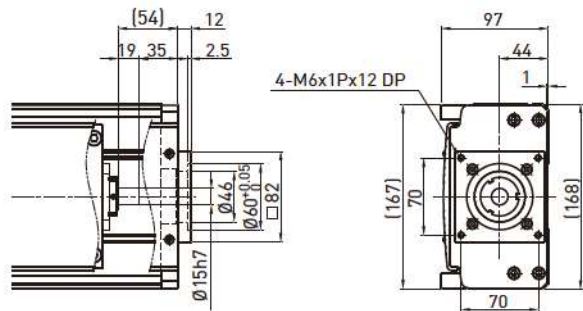

Motor Adaptor Flange F2

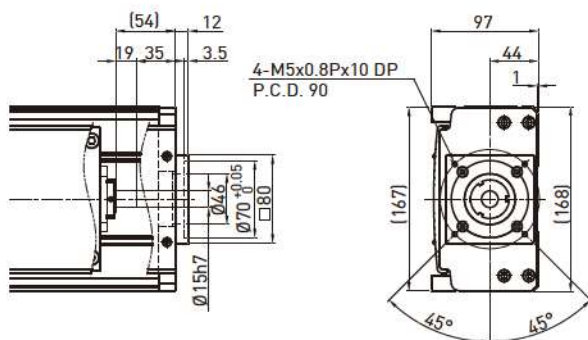

Motor Adaptor Flange F4

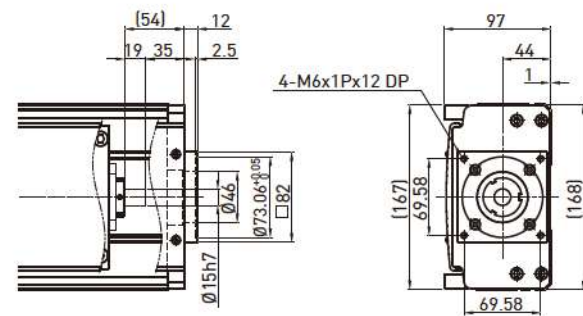

KA200

Motor Adaptor Flange F0

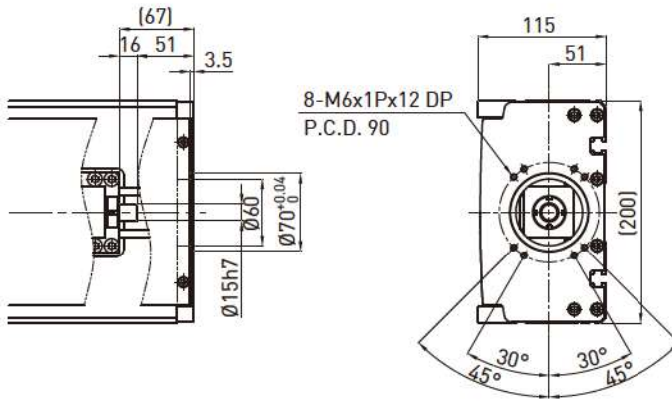

Motor Adaptor Flange F1

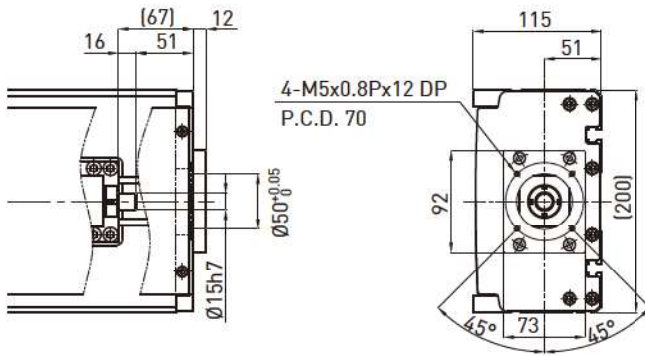

Motor Adaptor Flange F2

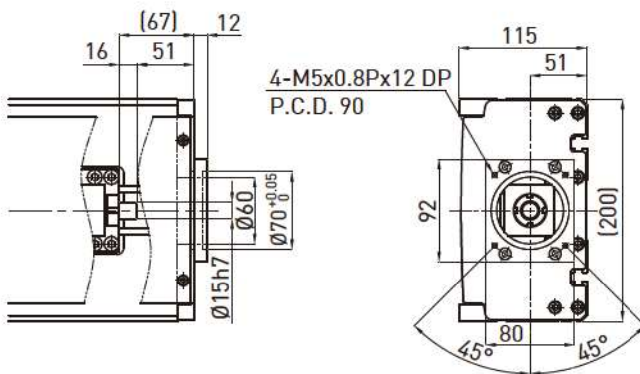

5.13 Motor Housing and Motor Adaptor Flange

HIWIN Mikrosystem Servo Motor

Motor Output	Motor	Flange Selection							Drive	Remarks
		KA90	KA100	KA120	KA136	KA150	KA170	KA200		
50W	FRLS052□□A4□	F1	F1	F1	F3	F3	-	-	D2T-0123-S-A□	220V
100W	FRLS102□□A4□	F1	F1	F1	F3	F3	-	-		220V
200W	FRLS202□□06□	-	-	-	F0	F0	F0	F1	D2T-0423-S-B□	220V
400W	FRLS402□□06□	-	-	-	F0	F0	F0	F1		220V
750W	FRMS752□□08□	-	-	-	-	-	F1	F0	D2T-1023-S-C□	220V

Mitsubishi Servo Motor

Motor Output	Motor	Flange Selection							Drive	Remarks
		KA90	KA100	KA120	KA136	KA150	KA170	KA200		
50W	HF-KP053	F0	F0	F0	F2	F2	-	-	MR-J3S-10A	220V
100W	HF-KP13	F0	F0	F0	F2	F2	-	-	MR-J3S-10A	220V
200W	HF-KP23	-	-	-	F0	F0	F0	F1	MR-J3S-20A	220V
400W	HF-KP43	-	-	-	F0	F0	F0	F1	MR-J3S-40A	220V
750W	HF-KP73	-	-	-	-	-	F1	F0	MR-J3S-70A	220V

Panasonic Servo Motor

Motor Output	Motor	Flange Selection							Drive	Remarks
		KA90	KA100	KA120	KA136	KA150	KA170	KA200		
50W	MSMD5AZP1	F1	F1	F1	F3	F3	-	-	MADDT1105	110V
50W	MSMD5AZP1	F1	F1	F1	F3	F3	-	-	MADDT1205	220V
100W	MSMD011P1	F1	F1	F1	F3	F3	-	-	MADDT1107	110V
100W	MSMD012P1	F1	F1	F1	F3	F3	-	-	MADDT1205	220V
200W	MSMD021P1	-	-	-	F1	F1	-	-	MADDT2110	110V
200W	MSMD022P1	-	-	-	F1	F1	-	-	MADDT1207	220V
400W	MSMD041P1	-	-	-	F1	F1	-	-	MADDT3120	110V
400W	MSMD042P1	-	-	-	F1	F1	-	-	MADDT2210	220V
750W	MSMD082S1	-	-	-	F4	F4	F2	F2	MADDT3520	220V

Yasukawa Servo Motor

Motor Output	Motor	Flange Selection							Drive	Remarks
		KA90	KA100	KA120	KA136	KA150	KA170	KA200		
50W	SGMAV-A5ADA61	F0	F0	F0	F2	F2	-	-	SGDV-R70A01A	with key
50W	SGMAV-A5ADA2C	F0	F0	F0	F2	F2	-	-	SGDV-R70A01A	no key
50W	SGMAV-A5ADA21	F0	F0	F0	F2	F2	-	-	SGDV-R70A01A	no key
100W	SGMAV-01ADA21	F0	F0	F0	F2	F2	-	-	SGDV-R90A01A	
200W	SGMAV-02ADA21	-	-	-	F0	F0	F0	F1	SGDV-1R6A01A	
400W	SGMAV-04ADA21	-	-	-	F0	F0	F0	F1	SGDV-2R8A01A	
750W	SGMAV-08ADA21	-	-	-	-	-	F1	F0	SGDV-5R5A01A	

Oriental Step Motor

Series	Model	Flange Selection							Drive	Remarks
		KA90	KA100	KA120	KA136	KA150	KA170	KA200		
CSK 2 phase	CSK243-AP	-	-	-	-	-	-	-		
	CSK244-AP	-	-	-	-	-	-	-		
	CSK245-AP	-	-	-	-	-	-	-		
	CSK264-AP	-	-	-	F6	F6	-	-		
	CSK266-AP	-	-	-	F6	F6	-	-		
	CSK268-AP	-	-	-	F6	F6	-	-		
	CSK296-AP	-	-	-	-	-	F4	-		
	CSK299-AP	-	-	-	-	-	F4	-		
	CSK2913-AP	-	-	-	-	-	F4	-		
CFKII 5 phase micro stepping	CFK543AP2	-	-	-	-	-	-	-		
	CFK544AP2	-	-	-	-	-	-	-		
	CFK545AP2	-	-	-	-	-	-	-		
	CFK564AP2	-	-	-	F5	F5	-	-		
	CFK566AP2	-	-	-	F5	F5	-	-		
	CFK569AP2	-	-	-	F5	F5	-	-		
	CFK566HAP2	-	-	-	F5	F5	-	-		
	CKF569HAP2	-	-	-	F5	F5	-	-		
	CFK596HAP2	-	-	-	-	-	F3	-		
CFK599HAP2	-	-	-	-	-	F3	-			
CFK5913HAP2	-	-	-	-	-	F3	-			
UMK 2 phase	UMK243A	-	-	-	-	-	-	-		
	UMK244A	-	-	-	-	-	-	-		
	UMK245A	-	-	-	-	-	-	-		
	UMK264A	-	-	-	F6	F6	-	-		
	UMK266A	-	-	-	F6	F6	-	-		
	UMK268A	-	-	-	F6	F6	-	-		
RK 5 phase	RK543AA	-	-	-	-	-	-	-		
	RK544AA	-	-	-	-	-	-	-		
	RK545AA	-	-	-	-	-	-	-		
	RK566AA	-	-	-	F5	F5	-	-		
	RK569AA	-	-	-	F5	F5	-	-		
	RK596AA	-	-	-	-	-	F3	-		
	RK599AA	-	-	-	-	-	F3	-		
	RK5913AA	-	-	-	-	-	F3	-		