

Linear Actuator

4-2. HIWIN LAN Series (2)

LAN3A

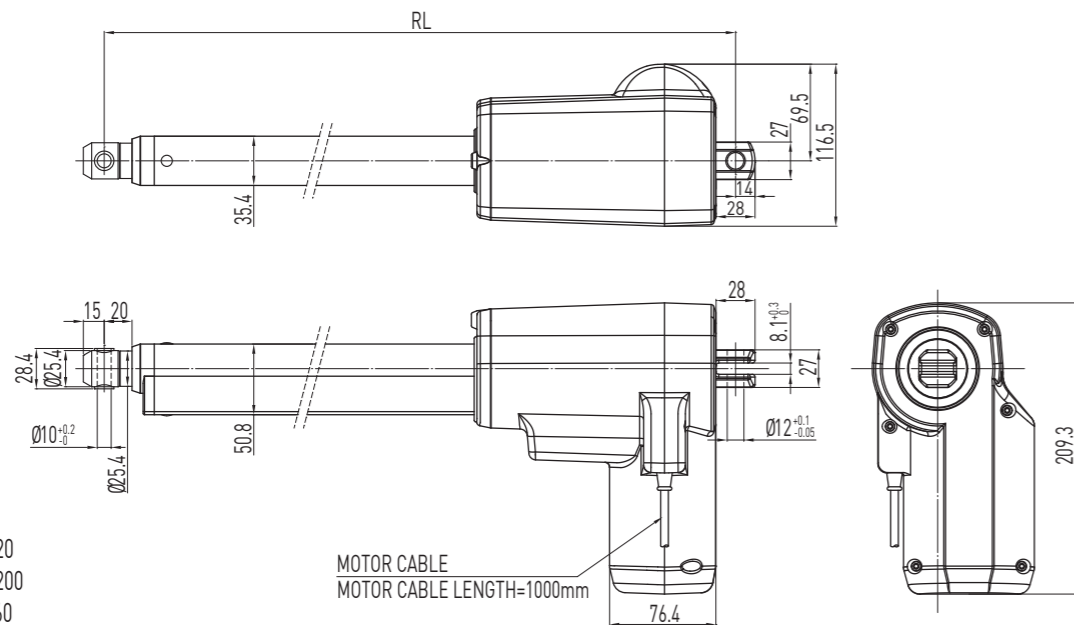

- RL = S+220
Stroke < 200
RL = S+260
Stroke: 200-500mm
RL: Retracted length
S: Stroke length

Table 4.4 Specifications

Screw type	ACME
Weight*	5.2kg
Protection	IP54
Compatible controller	LAK6B / LAK2J
Working temp.	+5°C-40°C

* Stroke length 200mm

Apply:

Large thrust with (1.2Nt)

Option:

- (1) IP66
- (2) Potentiometer 10K ohm (RL = S+231, S < 200mm / RL = S+271, S: 200-500mm)
* The max. stroke lengths with potentiometer: LAN3A-1 Max.280mm, LAN3A-2 Max.420mm, LAN3A-3 Max.560mm, LAN3A-4 Max.700mm
- (3) Mechanical Spline(push only) (RL = S+262, S < 200mm / RL = S+302, S: 200-500mm)
- (4) Safety Nut (RL = S+232, S < 200mm / RL = S+272, S: 200-500mm);
Safety Nut+Mechanical Spline (RL = S+269, S < 200mm / RL = S+309, S = 200-500mm)
- (5) Mechanical quick release
- (6) Back fixture turned 90°
- (7) Fast motor 24Q
- (8) External reed switches (RL = S+300, S < 200mm / RL = S+340, S = 200-500mm)
- (9) MR Sensor feedback
- (10) Plug: DIN 4PIN plug / Stereo plug / Mono plug
- (11) UL Version
- (12) Anti-UV material

Table 4.5 LAN3A Specifications

Model	Thrust max. (N)	Pulling max. (N)	Holding max. (N)	Speed (mm/s) Load = Max. / Load = 0	Standard stroke (mm) : S	Duty cycle %	Current max. (A) 24VDC	Potentiometer Resolution (Ohm/mm)	MR Sensor Resolution (mm/pulse)
LAN3A-1	12000	6000	12000	3/5	100 150 200 250 300 350 - - -	10	8.3	33.3	0.1
LAN3A-2	10000	6000	10000	4.5/8	100 150 200 250 300 350 400 - - -	10	8.3	22.2	0.16
LAN3A-3	7000	6000	7000	7/9	100 150 200 250 300 350 400 450 - - -	10	8	16.7	0.22
LAN3A-4	5000	5000	5000	9.5/12.5	100 150 200 250 300 350 400 450 500	10	7	13.3	0.27

* Min. input power = Voltage x Current max.

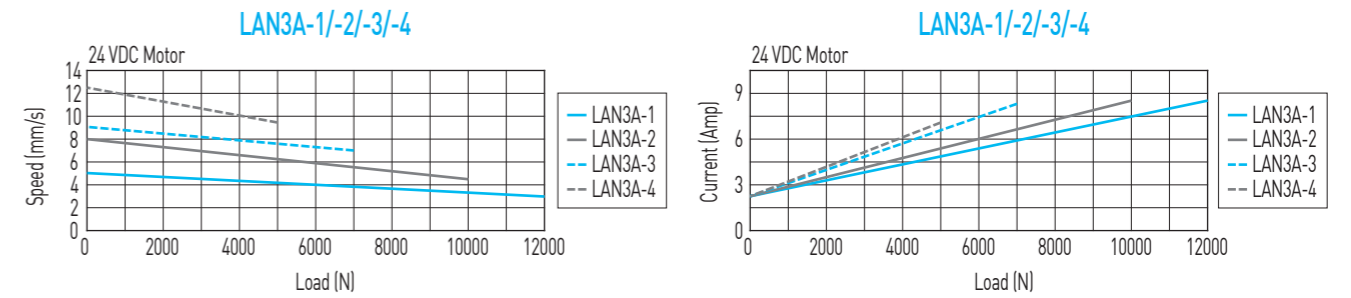

**Note: The test results are obtained by using the 24VDC power supply and holding by motor short-circuited.

Table 4.6 LAN3A (Fast Motor 24Q)

Model	Thrust max. (N)	Pulling max. (N)	Holding max. (N)	Speed (mm/s) Load = Max. / Load = 0	Standard stroke (mm) : S	Duty cycle %	Current max. (A) 24VDC	Potentiometer Resolution (Ohm/mm)	MR Sensor Resolution (mm/pulse)
LAN3A-1	12000	6000	12000	4.5/7	100 150 200 250 300 350 - - -	10	12	33.3	0.1
LAN3A-2	10000	6000	10000	7/11	100 150 200 250 300 350 400 - - -	10	12	22.2	0.16
LAN3A-3	7000	6000	7000	9/13	100 150 200 250 300 350 400 450 - - -	10	12	16.7	0.22
LAN3A-4	5000	5000	5000	13/18	100 150 200 250 300 350 400 450 500	10	12	13.3	0.27

* Min. input power = Voltage x Current max.

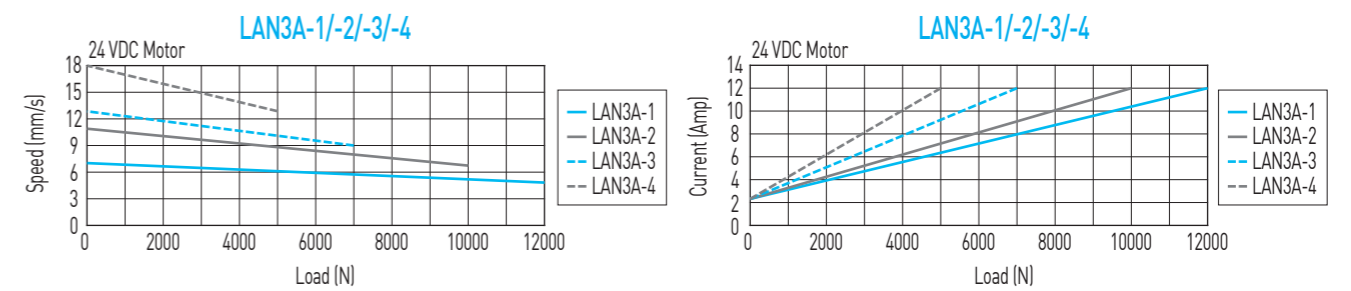

**Note: The test results are obtained by using the 24VDC power supply and holding by motor short-circuited.

Ordering Information

LAN3A - 1 1 - 1 - 200 - 24 G E

Model number	Force direction	1: Basic model complete with internal limit switches	Stroke length	Voltage	Color	Special models according to the customer's requirement (Ignore this part of the serial number if not available)
	1: Standard 2: Suspending install, pull			24: Standard motor 24Q: Fast motor	B: Black G: Gray	

Linear Actuator

4-3. HIWIN LAN Series (3)

LAN4

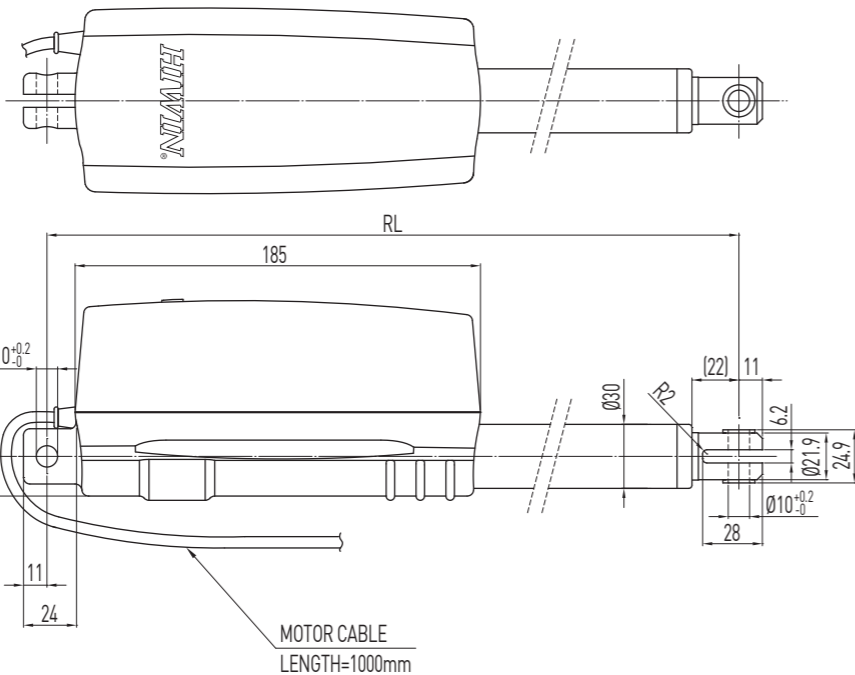
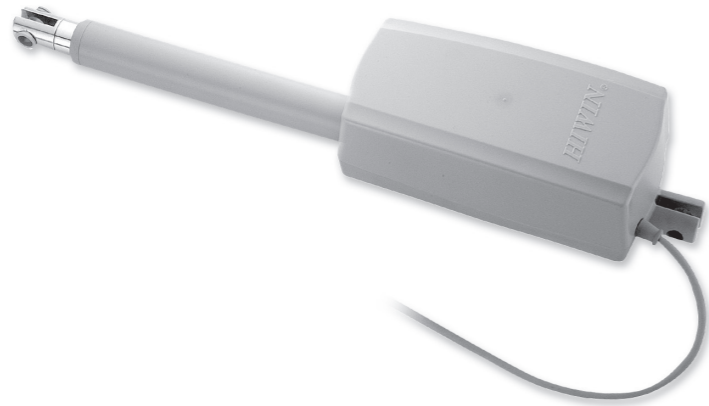

- RL = S+160
- Stroke ≤ 400
- RL: Retracted length
- S: Stroke length

Table 4.7 Specifications

Screw type	ACME
Weight*	2.33kg
Protection	IP54
Compatible controller	LAK2 / LAK2LR / LAK2D / LAK2BN / LAK2J / LAK6B
Working temp.	+5°C~40°C

* Stroke length 200mm

Option:

- (1) IP66
- (2) Safety Nut RL = S+174, S ≤ 400
- (3) Mechanical spline (push only) RL = S+200, S ≤ 400
- (4) Plug: DIN 4PIN plug / Stereo plug / Mono plug
- (5) UL Version

Table 4.8 LAN4 Specifications

Model	Thrust max. (N)	Pulling max. (N)	Holding max. (N)	Speed (mm/s) Load = Max. / Load = 0	Standard stroke (mm) : S								Duty cycle %	Current max. (A)	
					100	150	200	250	300	350	400	24VDC		12VDC	
LAN4-1	3500	3500	3500	3.5/7	100	150	200	250	300	350	400	10	6	12	
LAN4-2	3000	3000	3000	4.2/9	100	150	200	250	300	350	400	10	6	12	
LAN4-3	2000	2000	2000	6/13	100	150	200	250	300	350	400	10	5	12	
LAN4-4	1500	1500	1500	8.5/20	100	150	200	250	300	350	400	10	5	12	

* Min. input power = Voltage x Current max.

LAN4-1/-2/-3/-4

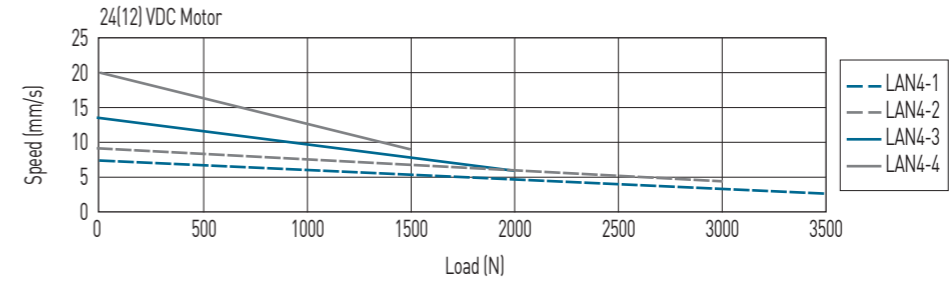

LAN4-1/-2/-3/-4

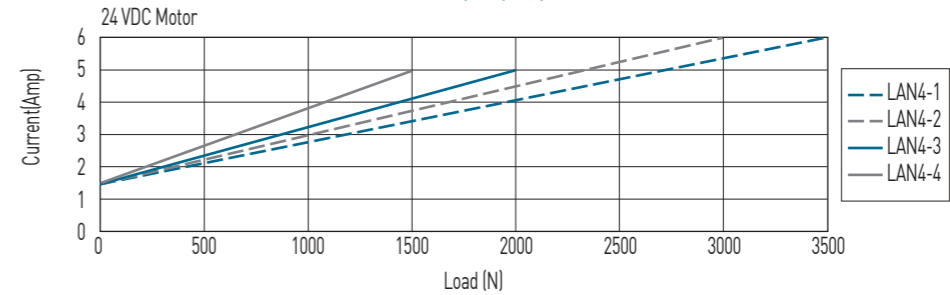

**Note: The test results are obtained by using the 24VDC power supply.

LAN4-1/-2/-3/-4

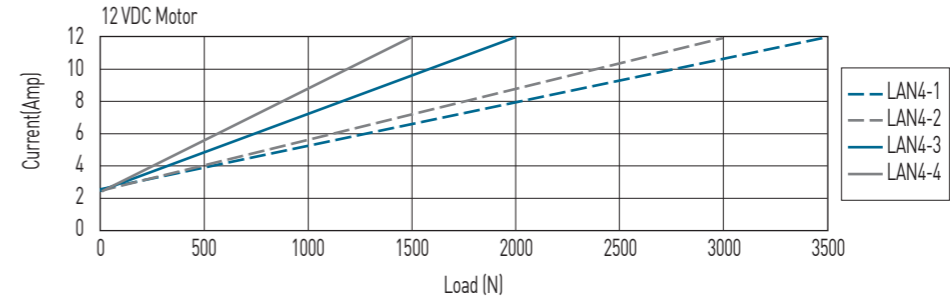

**Note: The test results are obtained by using the 12VDC power supply.

Ordering Information

LAN4 - 1 - 0 - 300 - 24 G E					
Model number	0: Basic model *1: Over-Current protection	Stroke length	Voltage 24: Standard motor 12: 12VDC Standard	Color B: Black G: Gray	Special models according to the customer's requirement (Ignore this part of the serial number if not available)

* Remark: The over-current protection is for over load protection, do not use for limit stop.
Suggestion: To add external limit switch as limit positions stop.

Linear Actuator

4-4. HIWIN LAN Series (4)

LAN5



- LAN5-1
RL = S+163
Stroke ≤ 200
RL: Retracted length
S: Stroke length
- Other spec.
RL = S+163
Stroke ≤ 250
RL = S+213
Stroke = 300
RL: Retracted length
S: Stroke length

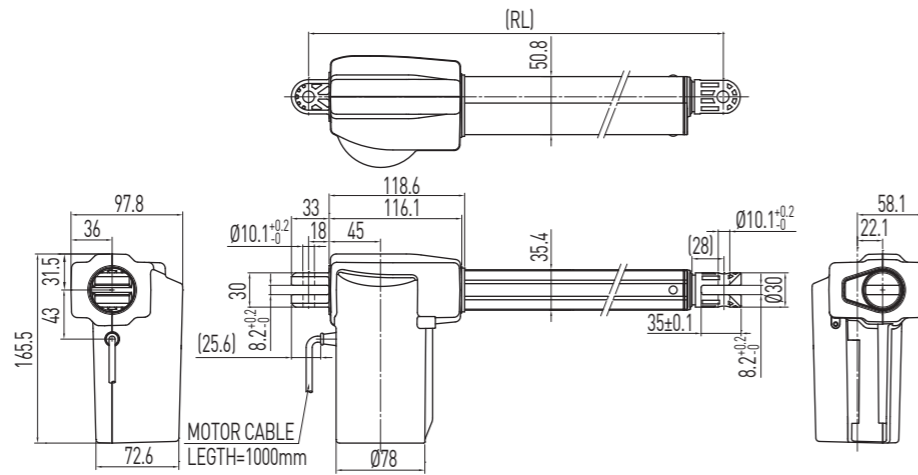

QUICK RELEASE

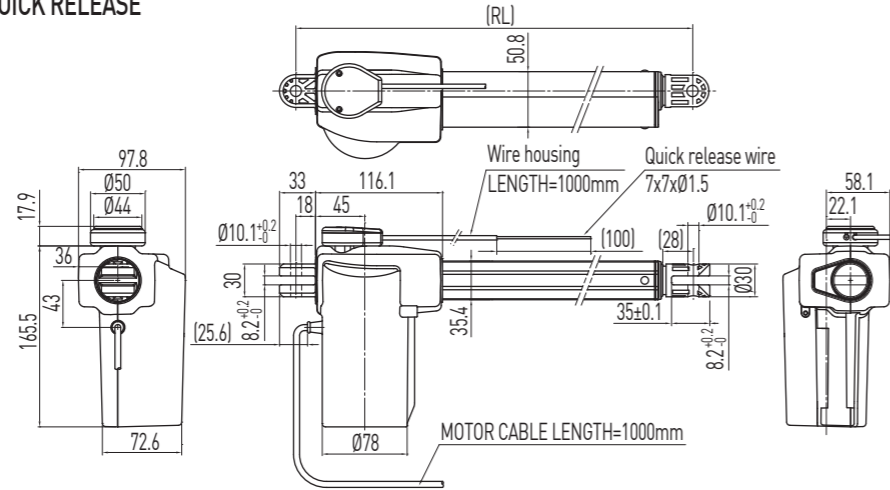

Quick release function:

- (1) The quick release cable can be pulled while the load on actuator under 100N.
- (2) When the quick release is activated, the actuator must have a load over 700N to ensure the actuator runs inwards.
- (3) After quick release activated, it may be necessary to run the actuator inwards.

Table 4.9 Specifications

Screw type	ACME
Weight*	1.96kg
Protection	IP54
Compatible controller	Compatible with all kinds of controller [*Notice the type of connector: Audio/DIN 4PIN]
Working temp.	+5°C~40°C

* Stroke length 200mm

Option:

- | | | |
|-----------------------------------|---|---|
| (1) Hall Sensor | (4) Back fixture turned 0°, 45°, 90°, 135° | (7) UL version(Only 24VDC Motor) |
| (2) Safety nut | (5) IP65; IP66 | (8) Plug: DIN 4PIN plug / Stereo plug / Mono plug |
| (3) Mechanical Spline (push only) | (6) Quick release (For LAN5-3, LAN5-4 only) | |

Table 4.10 Position feedback specifications (Hall Sensor)

Supply voltage	24VDC	12VDC	5VDC
Output	High level 24VDC Low level 0.2V / 10mA sink (NPN)	High level 12VDC Low level 0.2V / 10mA sink (NPN)	TTL

Table 4.11 LAN5 Specifications

Model	Thrust max. (N)	Pulling max. (N)	Holding max. (N)	Speed (mm / s) Load = Max. / Load = 0	Standard stroke (mm) : S	Duty cycle %	Current max. (A) 24VDC	Hall Sensor Resolution (mm/pulse)
LAN5-1	8000	4000	6000	2 / 3.5	100 150 200	10	5	0.08
LAN5-2	6000	4000	5000	3 / 4.5	100 150 200 250	10	4.5	0.10
LAN5-3	4000	3000	4000	4 / 5.5	100 150 200 250 300	10	4	0.14
LAN5-4	3000	2000	1500	6 / 9	100 150 200 250 300	10	4	0.22

* When the stroke of LAN5-1 is between 250mm and 300mm, refer to the diagram on the right for max. load.

* LAN5-4 24V Quick release Holding max. 1000N

* LAN5-3 24V Quick release Holding max. 3000N

* Min. input power = Voltage x Current max.

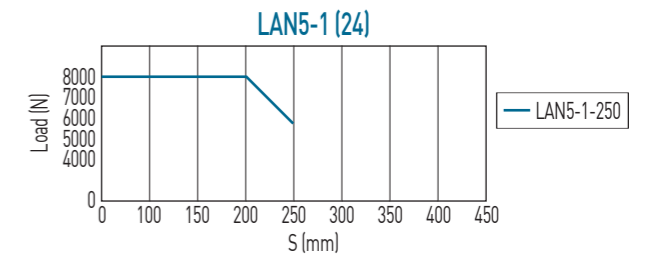
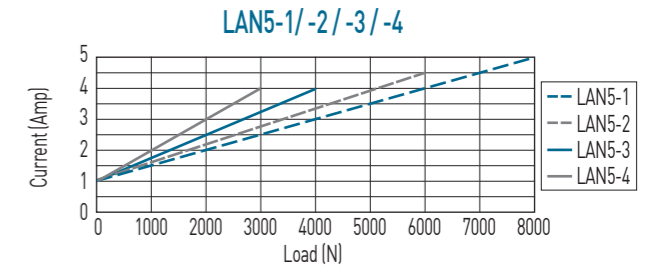
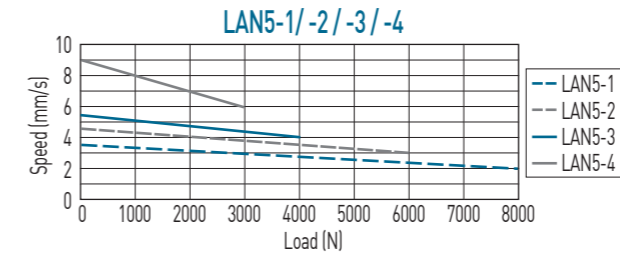

**Note: The test results are obtained by using the 24VDC power supply.

Table 4.12 LAN5(24Q) Specifications

Model	Thrust max. (N)	Pulling max. (N)	Holding max. (N)	Speed (mm / s) Load = Max. / Load = 0	Standard stroke (mm) : S	Duty cycle %	Current max. (A) 24VDC	Hall Sensor Resolution (mm/pulse)
LAN5-1	7000	4000	6000	5 / 7	100 150 200	10	8	0.08
LAN5-2	6000	4000	5000	7 / 9	100 150 200 250	10	8	0.10
LAN5-3	4000	3000	4000	9 / 11	100 150 200 250 300	10	6	0.14
LAN5-4	3000	2000	1500	14 / 19	100 150 200 250 300	10	6	0.22

* When the stroke of LAN5-1 is between 250mm and 300mm, refer to the diagram on the right for max. load.

* LAN5-4 24Q Quick release Holding max. 1000N

* LAN5-3 24Q Quick release Holding max. 3000N

* Min. input power = Voltage x Current max.

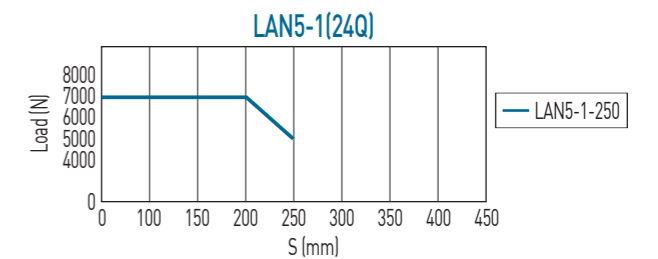
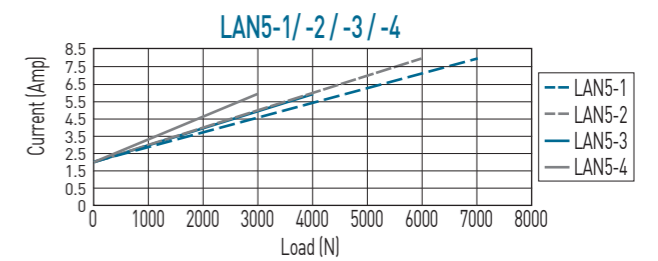
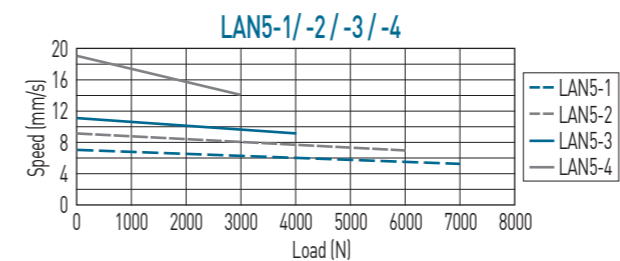

Ordering Information

Model number	Force direction 1: Standard 2: Suspending install, pull	1: Basic model complete with internal limit switches	Stroke length	Voltage 24: Standard motor 24Q: Fast motor	Color B : Black G : Gray	Special models according to the customer's requirement (Ignore this part of the serial number if not available)
--------------	---	--	---------------	--	--------------------------------	---