



# KEYLESS LOCKING DEVICES



DRIVE  
SOLUTIONS



**SIT-LOCK®  
INTRODUCTION**

**3 ÷ 13**



**MONOLOCK**

**15 ÷ 18**



**SIT-LOCK®  
INTERNAL LOCKING DEVICE  
SELF-CENTERING**

**19 ÷ 50**



**SIT-LOCK®  
INTERNAL LOCKING DEVICE  
NOT SELF-CENTERING**

**51 ÷ 64**



**SIT-LOCK®  
SHRINK DISC**

**65 ÷ 82**



**SIT-LOCK®  
LOCKING DEVICES  
FOR APPLICATIONS WITH  
HIGH BENDING MOMENTS**

**83 ÷ 92**



# SIT-LOCK® Keyless locking devices

## INDEX

<b>SIT-LOCK®</b>	<b>PAGE</b>
<b>keyless locking devices for shaft-hub connection</b>	
SIT-LOCK® keyless locking device advantages compared to conventional systems	3 - 4
Formulas for correct SIT-LOCK® locking device use	5
Calculating the minimum hub diameter $D_{min}$	6 - 7
SIT-LOCK® locking device features	8 ÷ 11
SIT-LOCK® applications	12 - 13
<b>INTERNAL LOCKING DEVICES</b>	
<b>Self-centering</b>	
SIT-LOCK® 30 MONOLOCK	16 ÷ 18
SIT-LOCK® 3	20 - 21
SIT-LOCK® 20	22 - 23
SIT-LOCK® 4	24 - 25
SIT-LOCK® 4A	26 - 27
SIT-LOCK® 4C	28 - 29
SIT-LOCK® 5A	30 - 31
SIT-LOCK® 5B	32 - 33
SIT-LOCK® 6	34 - 35
SIT-LOCK® 7	36 - 37
SIT-LOCK® 8	38 - 39
SIT-LOCK® 12	40 - 41
SIT-LOCK® 15	42 - 43
SIT-LOCK® 16	44 - 45
SIT-LOCK® 18	46 - 47
SIT-LOCK® 13	48 - 49
<b>Not self-centering</b>	
SIT-LOCK® 1	52 - 53
SIT-LOCK® 9	54 - 55
SIT-LOCK® 2	56 - 57
SIT-LOCK® 10 rigid joint	58 - 59
Application examples	60
Customised versions available on request	61 - 62
Application diagram for internal locking devices	63
<b>SHRINK DISCS</b>	
SIT-LOCK® 11	66 ÷ 72
SIT-LOCK® 14	73 ÷ 78
Application examples	79
Customised versions available on request	80 - 81
Application diagram for shrink discs	82
<b>LOCKING DEVICES FOR HIGH BENDING MOMENT</b>	
Introduction	84 - 85
SIT-LOCK® 1	86
SIT-LOCK® 7	87
SIT-LOCK® 4C	88
SIT-LOCK® 20	89
SIT-LOCK® 4	90
SIT-LOCK® 22	91

### SIT-LOCK® LOCKING DEVICE CODES

Keyless locking devices	CAL	1	F25	/50
CAL: SIT-LOCK® Keyless locking devices				
Type				
Shaft diameter [mm]				
Outside diameter (hub bore) - [mm]				

**NOTE:** FOR EXTERNAL LOCKING DEVICES THE  $d$  DIAMETER IS INDICATED, NOT THE  $d_w$  DIAMETER.

# SIT-LOCK® keyless locking device advantages compared to conventional systems

A shaft to hub lock is critical in the design of a mechanical transmission as an unsuitable choice could cause serious damage to the machine or system and result in economic loss. Shaft-hub coupling designs must take several parameters into account:

- assessing application loads: torque, bending moment, axial force, radial force. Stresses that may occur simultaneously;
- alternating loads, sudden starts and stops, very rapid acceleration;
- fatigue limits of the coupling components;
- suitable material use;
- frequent installation and removal requirements;
- fretting corrosion.

As mentioned, coupling breakages could cause high economic damages due to:

- downtime and subsequent production loss;
- damage to other parts of the system;
- material damage to persons or property.

Traditional shaft-hub locking systems include:

- feather keys
- key
- spline coupling
- interference coupling: forced

We assess the features of the traditional systems:

## Feather keys

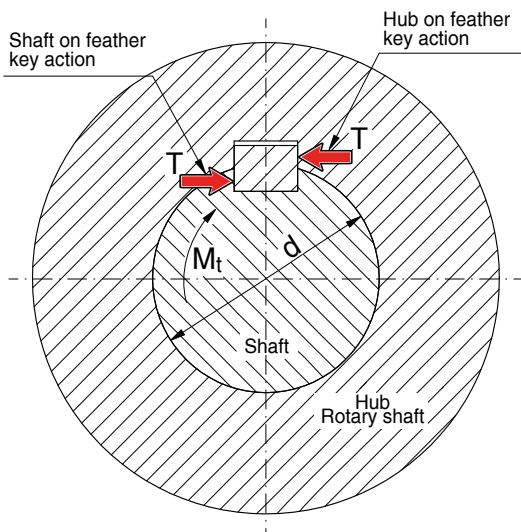

Feather key couplings are the most commonly used, we consider some of the disadvantages:

- high concentration of stress on the shaft and hub due to the high pressure generated on the keyway sides;
- micro-movements caused by the lack of even contact can cause fretting corrosion making it difficult to remove;
- not recommended for alternating loads. Over time, the pressure generated on the keyway sides can widen it and cause the shaft or hub to break. Not recommended in damp environments;

- the lack of contact over the shaft-hub surface may lead to oxidation, making it difficult to remove;
- cannot accept axial loads;
- not recommended for transmissions that require zero backlash;
- significant decrease in shaft strength due to the keyway;
- difficult axial and angular positioning.

## Keys

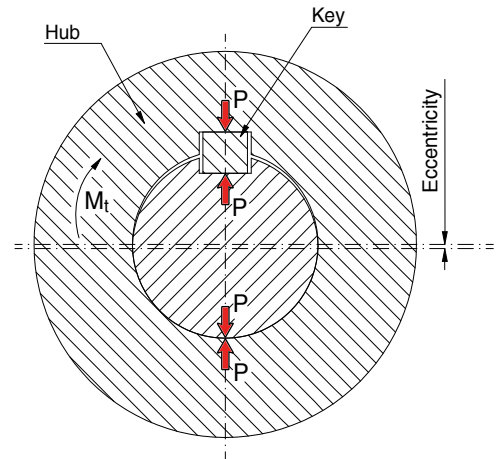

Keyed shaft-hub couplings have the same disadvantages as feather key couplings and also cause significant hub-to-shaft concentricity error.

## Splined profile

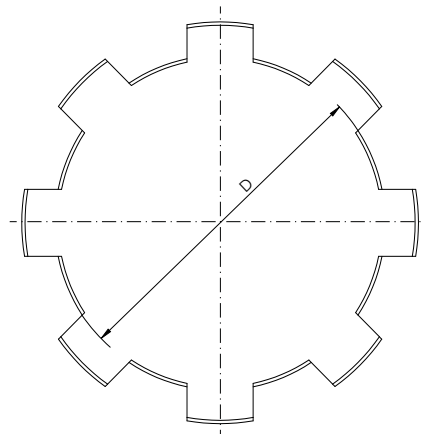

This coupling has the following disadvantages:

- fretting corrosion from the lack of contact making it difficult to remove;
- significant decrease in shaft strength;
- increased cost as it is difficult to make;
- play between shaft and hub;
- difficult angular and axial positioning;
- not recommended in damp or dusty environments. Lack of contact may impair removal.

# SIT-LOCK® keyless locking device advantages compared to conventional systems

## Interference fit

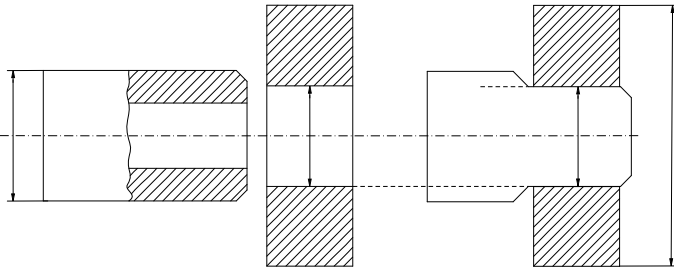

Interference fit shaft-hub connections can be achieved by cooling the shaft or heating the hub. This type of connection is not widely used for the following reasons:

- requires tight tolerances;
- difficult to remove;
- locking area temperature changes;
- the effect of the centrifugal force created by the hub can decrease transmissible torque;
- increased stress concentrated on the edges.

## Shaft strength depends on the type of coupling used

As an example, we look at the following data. For a shaft with a diameter  $d$  equal to 50 mm, its shaft strength would match the diameter of:

- 39 mm feather key coupling
- 35 mm splined shaft coupling
- 46 mm interference fit
- 49 mm SIT-LOCK® coupling

## Note

Incorrect calculations that do not account for all the stresses in a shaft-hub coupling can cause irreparable shaft breakage. Below is an example of fatigue failure caused by shaft-hub locking using a feather key.



## SIT-LOCK® locking device coupling

Simply by tightening the screws, SIT-LOCK® keyless locking devices create an axial force on the shaft and the hub that is spread over the entire contact surface. Unlike traditional systems, they offer numerous advantages. The main ones are listed below.

## Calculation ease

All the information, transmissible torque, axial force limits, etc., can be found in the catalogue. No additional calculations are required.

## Installation and removal

Quick and easy. When installing, the screws simply need to be tightened to the  $M_s$  value indicated in the table. For removal, however, the screws need to be loosened evenly. In addition, there are assembly threads that allow the coupled parts to unlock even under extreme conditions.

## Shaft and hub tolerances and surface finish

Tight tolerances are not necessary. h8/H8 tolerances are typically used. Some products may allow for h11/H11 tolerances. All the information is available in the catalogue.

## Operating temperatures

The values shown in the tables are valid for temperatures from -20 °C to +200 °C. For uses lower or higher than these values, please contact our Technical Department.

## Simultaneous loads possible

Using SIT-LOCK® locking devices allows simultaneous torque, axial force, bending moment and radial force. For further information or calculations, please contact our Technical Department.

## Increased shaft strength

The shaft has no slots and the pressure generated by tightening the screws does not cause any reduction of the shaft's strength. This enables the diameter of the shaft to be reduced with the same stresses applied, leading to considerable savings on costs.

## Easy axial and angular adjustment

Unlike conventional couplings, SIT-LOCK® locking devices simply require placing the hub in the desired position relative to the shaft and tightening the screws.

## Oxidation protection

Even in damp environments, the pressures created along the contact surfaces do not allow for oxidation, ensuring easy removal of the locked parts.

## No backlash

Connection in transmissions using SIT-LOCK® locking devices are perfectly rigid and there is no backlash that could impair motion transmission or machine precision over time.

## Recommended for applications subject to continuous alternating loads

By using SIT-LOCK® locking devices, the stresses generated by alternating or sudden loads are distributed over the entire surface of the shaft and not over a reduced section as occurs with traditional systems.

## Formulas for proper SIT-LOCK® locking device use

All the values in the table have been calculated and verified by our Technical Department. All the information for proper use is shown in the table. By tightening the screws to the torque  $M_s$  indicated in the table, an axial force  $P_v$  occurs which generates a radial force  $N$  on the shaft and hub contact surfaces. The pressure generated on the shaft and hub determines the transmissible torque  $M_t$  indicated in the table.

Therefore:

$$M_t = N \cdot \mu \cdot \frac{d}{2}$$

The coefficient of friction  $\mu$  used to calculate the locking device transmissible torque  $M_t$  is:

- 0.12 (oiled surfaces) for internal locking devices
- 0.15 (dry surfaces) for external locking devices

This means that for the locking devices with calculated values, with a coefficient of friction  $\mu$  0.12, a higher torque can be transmitted without further increasing the screw tightening torque  $M_s$ . Our Technical Department is available for further clarifications and calculations.

Avoid using molybdenum disulphide based lubricants or greases on the shaft and hub contact surfaces as this would considerably decrease the friction coefficient  $\mu$ .

### Calculating the minimum hub diameter $D_{min}$

See the following pages.

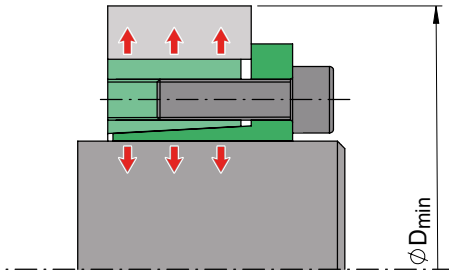

### Screw tightening torque $M_s$

Where necessary, the screw tightening torque  $M_s$  can be reduced. As a result, the transmissible torque  $M_t$  indicated in the tables decreases proportionally. The same applies to the axial force limits  $F_{ax}$  and the pressure generated on the shaft  $P_w$  and hub  $P_n$ . The tightening torque  $M_s$  can be decreased by 30% or 40% of the value indicated in the tables.

### Temperature influence

The values in the table are typically valid for applications from -20 °C to +200 °C. In extreme cases, it is possible to use them from -40 °C to +300 °C. For applications subject to high temperatures, we recommend using shafts and hubs with the same coefficient of thermal expansion. For more details, please contact our Technical Department.

### Applications with simultaneous torque and axial force

SIT-LOCK® locking devices can simultaneously transmit torque  $M_t$  and tolerate an axial force  $F_{ax}$ . The table shows the maximum permissible values. Where both values are present simultaneously, the transmissible torque  $M_t$  value decreases. Below is the formula for calculating transmissible torque:

$$M_{tam} = \sqrt{M_t^2 + \left(F_{axR} \cdot \frac{d}{2000}\right)^2}$$

- $M_{tam}$  = permissible torque (Nm)
- $M_t$  = required torque (Nm)
- $F_{axR}$  = required axial force (N)
- $d$  = shaft diameter (mm)

### Radial force influence

The radial force  $F_R$  affects the contact pressure on the shaft and hub generated by the locking device. Radial force generates an increase in pressure  $P_n$  generated on the hub. It is highly important to calculate this value as it must be used to verify the minimum hub diameter  $D_{min}$ .

$$\Delta P_n = \frac{F_R}{D \cdot H}$$

- $\Delta P_n$  = additional pressure on hub (N/mm<sup>2</sup>)
- $F_R$  = radial force applied (N)
- $D$  = external diameter of the locking device (mm)
- $H$  = locking device outer ring width (mm)

### Errors in concentricity and orthogonality

The concentricity tolerance of a SIT-LOCK® product designated as SELF-CENTRING is a maximum of 0.04 mm. The orthogonality error, measured on a hub diameter four times the shaft diameter, is a maximum of 0.08 mm. These values may be affected by a number of factors. For further details, please contact our Technical Department.

### Applications on shafts with bores

For use on a shaft with a bore corresponding to the pressure  $P_w$ , the maximum bore diameter  $d_B$  should be:

$$d_B \leq \sqrt{\frac{\sigma_{0,2} - (1,6 \cdot P_w)}{\sigma_{0,2}}} \cdot d$$

The maximum bore  $d_B$  will depend on the elastic load  $\sigma_{0,2}$  of the shaft material and the surface pressure  $P_w$  generated by the locking device (see table values). For hollow shaft applications, locking devices that generate low pressure are recommended.

## Calculating the minimum hub diameter $D_{min}$

To guarantee the torque transmission  $M_t$  indicated in the table when using a SIT-LOCK® internal locking device, the screws must be tightened to a specific torque  $M_s$ . Tightening the screws creates a pressure on the shaft  $P_w$  and on the hub  $P_n$ . To calculate the minimum hub diameter  $D_{min}$ , the formula generally used for measuring the thickness of thick-walled cylinders subject to high internal pressure is used. The formula for calculating  $D_{min}$  is:

$$D_{min} \geq D \cdot K$$

$D$  = outer diameter of the locking device in mm  
 $K$  = application coefficient

See table below.

The coefficient  $K$  is given by the following formula:

$$K = \sqrt{\frac{\sigma_{0,2} + (X \cdot P_n)}{\sigma_{0,2} - (X \cdot P_n)}}$$

Where:

$\sigma_{0,2}$  = hub material elastic limit in N/mm<sup>2</sup>  
 $X$  = factor depending on hub shape and width  
 $P_n$  = surface pressure on the hub

To simplify calculations, our Technical Department has drawn up a table for the coefficient  $K$  on the following page.

### Example calculation of minimum hub diameter $D_{min}$

Using the SIT-LOCK® 5B locking device to connect a shaft  $d = 50$  mm with a hub made out of a material that has an elastic load  $\sigma_{0,2} = 500$  N/mm<sup>2</sup>, and a shape type and hub width equivalent to  $X=1$ .

From the SIT-LOCK® 5B 50x80 table, the outer diameter  $D$  is equal to 80 mm, the pressure  $P_n$  on the hub is equal to 70 N/mm<sup>2</sup>. In the table on the next page, by taking the  $P_n$  value (70 N/mm<sup>2</sup>), the  $X$  value (1) and of the elastic load  $\sigma_{0,2}$  of the hub material (500 N/mm<sup>2</sup>), coefficient  $K$  can be found to be 1.15. Therefore:

$$D_{min} \geq D \cdot K \geq 80 \cdot 1,15 \geq 92 \text{ mm}$$

APPLICATION A  
 $X=1$

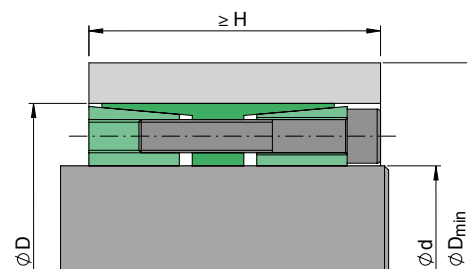
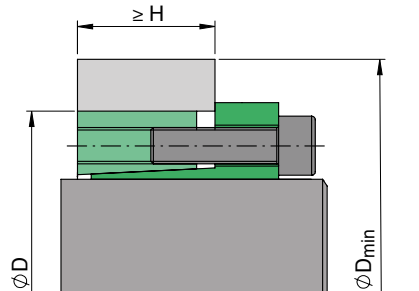

APPLICATION B  
 $X=0,8$

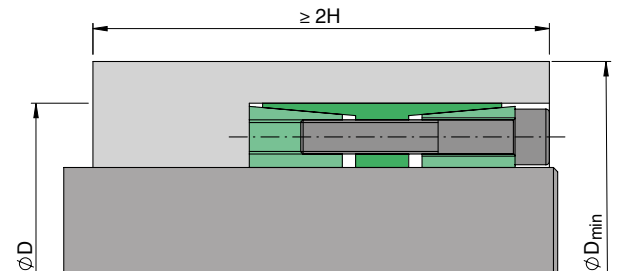
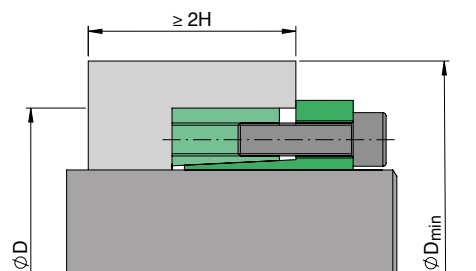

APPLICATION C  
 $X=0,6$

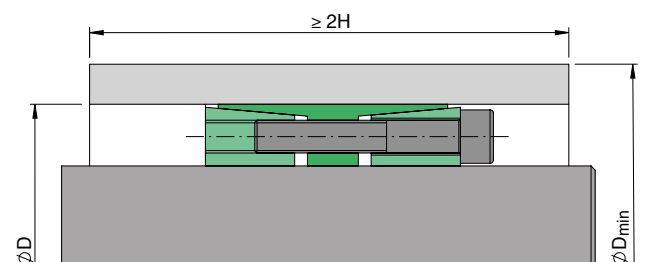
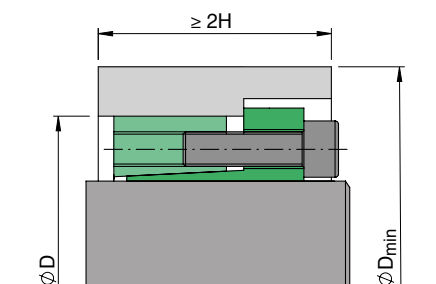

# Table of coefficient K

Pressure on hub $P_n$ [N/mm <sup>2</sup> ]	X factor  Application type	Elastic load of hub material $\sigma_{0,2}$ [N/mm <sup>2</sup> ]											
		150	180	200	220	250	270	300	350	400	450	500	600
		Hub material										Tempering steels	
		GG20	GG25	GG30	GS45	GGG40	St50-2	GGG50	GGG60	GGG70			
50	A X=1	1,41	1,33	1,29	1,26	1,22	1,21	1,18	1,15	1,13	1,12	1,11	1,09
	B X=0,8	1,31	1,25	1,22	1,20	1,18	1,16	1,14	1,12	1,11	1,09	1,08	1,07
	C X=0,6	1,22	1,18	1,16	1,15	1,13	1,12	1,11	1,09	1,08	1,07	1,06	1,05
55	A X=1	1,47	1,37	1,33	1,29	1,25	1,23	1,20	1,17	1,15	1,13	1,12	1,10
	B X=0,8	1,35	1,28	1,25	1,22	1,19	1,18	1,16	1,13	1,12	1,10	1,09	1,08
	C X=0,6	1,25	1,20	1,18	1,16	1,14	1,13	1,12	1,10	1,09	1,08	1,07	1,06
60	A X=1	1,53	1,41	1,36	1,32	1,28	1,25	1,22	1,19	1,16	1,14	1,13	1,11
	B X=0,8	1,39	1,31	1,28	1,25	1,21	1,20	1,18	1,15	1,13	1,11	1,10	1,08
	C X=0,6	1,28	1,22	1,20	1,18	1,16	1,14	1,13	1,11	1,09	1,08	1,07	1,06
65	A X=1	1,59	1,46	1,40	1,36	1,30	1,28	1,25	1,21	1,18	1,16	1,14	1,11
	B X=0,8	1,44	1,35	1,30	1,27	1,24	1,22	1,19	1,16	1,14	1,12	1,11	1,09
	C X=0,6	1,30	1,25	1,22	1,20	1,17	1,16	1,14	1,12	1,10	1,09	1,08	1,07
70	A X=1	1,66	1,51	1,44	1,39	1,33	1,30	1,27	1,22	1,19	1,17	1,15	1,12
	B X=0,8	1,48	1,38	1,33	1,30	1,26	1,23	1,21	1,18	1,15	1,13	1,12	1,10
	C X=0,6	1,33	1,27	1,24	1,21	1,18	1,17	1,15	1,13	1,11	1,10	1,09	1,07
75	A X=1	1,73	1,56	1,48	1,43	1,36	1,33	1,29	1,24	1,21	1,18	1,16	1,13
	B X=0,8	1,53	1,41	1,36	1,32	1,28	1,25	1,22	1,19	1,16	1,14	1,13	1,11
	C X=0,6	1,36	1,29	1,26	1,23	1,20	1,18	1,16	1,14	1,12	1,11	1,09	1,08
80	A X=1	1,81	1,61	1,53	1,46	1,39	1,36	1,31	1,26	1,22	1,20	1,18	1,14
	B X=0,8	1,58	1,45	1,39	1,35	1,30	1,27	1,24	1,20	1,18	1,15	1,14	1,11
	C X=0,6	1,39	1,31	1,28	1,25	1,21	1,20	1,18	1,15	1,13	1,11	1,10	1,08
85	A X=1	1,90	1,67	1,57	1,50	1,42	1,39	1,34	1,28	1,24	1,21	1,19	1,15
	B X=0,8	1,63	1,49	1,42	1,38	1,32	1,29	1,26	1,22	1,19	1,16	1,15	1,12
	C X=0,6	1,42	1,34	1,30	1,27	1,23	1,21	1,19	1,16	1,14	1,12	1,11	1,09
90	A X=1	2,00	1,73	1,62	1,54	1,46	1,41	1,36	1,30	1,26	1,22	1,20	1,16
	B X=0,8	1,69	1,53	1,46	1,40	1,34	1,31	1,28	1,23	1,20	1,18	1,16	1,13
	C X=0,6	1,46	1,36	1,32	1,28	1,25	1,22	1,20	1,17	1,15	1,13	1,11	1,09
95	A X=1	2,11	1,80	1,68	1,59	1,49	1,44	1,39	1,32	1,27	1,24	1,21	1,17
	B X=0,8	1,75	1,57	1,49	1,43	1,37	1,34	1,30	1,25	1,21	1,19	1,17	1,14
	C X=0,6	1,49	1,39	1,34	1,30	1,26	1,24	1,21	1,18	1,15	1,14	1,12	1,10
100	A X=1	2,24	1,87	1,73	1,63	1,53	1,48	1,41	1,34	1,29	1,25	1,22	1,18
	B X=0,8	1,81	1,61	1,53	1,46	1,39	1,36	1,31	1,26	1,22	1,20	1,18	1,14
	C X=0,6	1,53	1,41	1,36	1,32	1,28	1,25	1,22	1,19	1,16	1,14	1,13	1,11
105	A X=1	2,38	1,95	1,79	1,68	1,56	1,51	1,44	1,36	1,31	1,27	1,24	1,19
	B X=0,8	1,88	1,66	1,56	1,50	1,42	1,38	1,33	1,28	1,24	1,21	1,18	1,15
	C X=0,6	1,56	1,44	1,39	1,34	1,29	1,27	1,24	1,20	1,17	1,15	1,14	1,11
110	A X=1	2,55	2,04	1,86	1,73	1,60	1,54	1,47	1,38	1,33	1,28	1,25	1,20
	B X=0,8	1,96	1,71	1,60	1,53	1,44	1,40	1,35	1,29	1,25	1,22	1,19	1,16
	C X=0,6	1,60	1,47	1,41	1,36	1,31	1,28	1,25	1,21	1,18	1,16	1,14	1,12
115	A X=1	2,75	2,13	1,93	1,79	1,64	1,58	1,50	1,41	1,34	1,30	1,26	1,21
	B X=0,8	2,04	1,76	1,64	1,56	1,47	1,43	1,37	1,31	1,26	1,23	1,20	1,17
	C X=0,6	1,64	1,50	1,43	1,38	1,33	1,30	1,26	1,22	1,19	1,17	1,15	1,12
120	A X=1	3,00	2,24	2,00	1,84	1,69	1,61	1,53	1,43	1,36	1,31	1,28	1,22
	B X=0,8	2,13	1,81	1,69	1,60	1,50	1,45	1,39	1,33	1,28	1,24	1,21	1,18
	C X=0,6	1,69	1,53	1,46	1,40	1,34	1,31	1,28	1,23	1,20	1,18	1,16	1,13
125	A X=1	3,32	2,35	2,08	1,91	1,73	1,65	1,56	1,45	1,38	1,33	1,29	1,24
	B X=0,8	2,24	1,87	1,73	1,63	1,53	1,48	1,41	1,34	1,29	1,25	1,22	1,18
	C X=0,6	1,73	1,56	1,48	1,43	1,36	1,33	1,29	1,24	1,21	1,18	1,16	1,13
130	A X=1	3,74	2,49	2,17	1,97	1,78	1,69	1,59	1,48	1,40	1,35	1,30	1,25
	B X=0,8	2,35	1,93	1,78	1,67	1,56	1,50	1,44	1,36	1,30	1,27	1,24	1,19
	C X=0,6	1,78	1,59	1,51	1,45	1,38	1,35	1,30	1,25	1,22	1,19	1,17	1,14
135	A X=1	4,36	2,65	2,27	2,04	1,83	1,73	1,62	1,50	1,42	1,36	1,32	1,26
	B X=0,8	2,48	2,00	1,83	1,71	1,59	1,53	1,46	1,38	1,32	1,28	1,25	1,20
	C X=0,6	1,83	1,62	1,54	1,47	1,40	1,36	1,32	1,27	1,23	1,20	1,18	1,15
140	A X=1	5,39	2,83	2,38	2,12	1,88	1,78	1,66	1,53	1,44	1,38	1,33	1,27
	B X=0,8	2,63	2,07	1,88	1,75	1,62	1,55	1,48	1,39	1,33	1,29	1,26	1,21
	C X=0,6	1,88	1,66	1,56	1,50	1,42	1,38	1,33	1,28	1,24	1,21	1,18	1,15
145	A X=1	7,68	3,05	2,50	2,21	1,94	1,82	1,69	1,55	1,46	1,40	1,35	1,28
	B X=0,8	2,80	2,15	1,94	1,80	1,65	1,58	1,50	1,41	1,35	1,30	1,27	1,22
	C X=0,6	1,94	1,69	1,59	1,52	1,44	1,40	1,35	1,29	1,25	1,22	1,19	1,16
150	A X=1	-	3,32	2,65	2,30	2,00	1,87	1,73	1,58	1,48	1,41	1,36	1,29
	B X=0,8	3,00	2,24	2,00	1,84	1,69	1,61	1,53	1,43	1,36	1,31	1,28	1,22
	C X=0,6	2,00	1,73	1,62	1,54	1,46	1,41	1,36	1,30	1,26	1,22	1,20	1,16
155	A X=1	-	3,66	2,81	2,40	2,06	1,92	1,77	1,61	1,51	1,43	1,38	1,30
	B X=0,8	3,25	2,33	2,06	1,89	1,72	1,64	1,55	1,45	1,38	1,33	1,29	1,23
	C X=0,6	2,06	1,77	1,65	1,57	1,48	1,43	1,38	1,31	1,27	1,23	1,21	1,17
160	A X=1	-	4,12	3,00	2,52	2,13	1,98	1,81	1,64	1,53	1,45	1,39	1,31
	B X=0,8	3,55	2,43	2,13	1,94	1,76	1,67	1,58	1,47	1,39	1,34	1,30	1,24
	C X=0,6	2,13	1,81	1,69	1,60	1,50	1,45	1,39	1,33	1,28	1,24	1,21	1,18
165	A X=1	-	4,80	3,23	2,65	2,21	2,04	1,86	1,67	1,55	1,47	1,41	1,33
	B X=0,8	3,96	2,55	2,21	2,00	1,80	1,71	1,60	1,49	1,41	1,35	1,31	1,25
	C X=0,6	2,21	1,86	1,72	1,62	1,52	1,47	1,41	1,34	1,29	1,25	1,22	1,18

SIT-LOCK® keyless locking device

## SIT-LOCK® locking device features - internal

### SIT-LOCK® 3

- Self-centering
- Low surface pressures
- Suitable for using on hubs with a low  $\sigma_{0,2}$
- Available for shaft diameters of 6 to 130 mm
- No axial displacement when tightening the screws
- Compact dimensions
- Medium to high transmissible torques

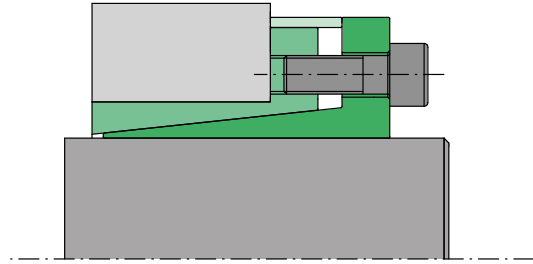

### SIT-LOCK® 20

- Self-centering
- High transmissible torque
- Available for shaft diameters of 45 to 400 mm
- No axial displacement when tightening the screws
- Even pressure distribution
- Removal using extraction threads
- Excellent perpendicularity

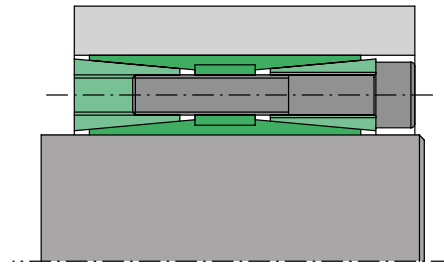

### SIT-LOCK® 4, SIT-LOCK® 4A, SIT-LOCK® 4C

- Self-centering
- High transmissible torque
- Available for shaft diameters of 25 to 500 mm
- Minimal axial movement of the hub shaft during tightening of the screws. (About 0,1 / 0,2 mm)
- Removal using extraction threads
- Excellent perpendicularity

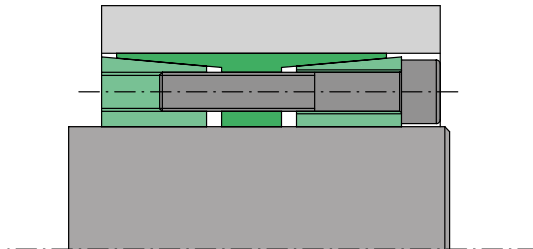

### SIT-LOCK® 5A

- Self-centering
- Even pressure distribution
- Available for shaft diameters of 18 to 240 mm
- Axial displacement when tightening screws
- Excellent shaft-to-hub perpendicularity
- High transmissible torques
- Quick installation and removal

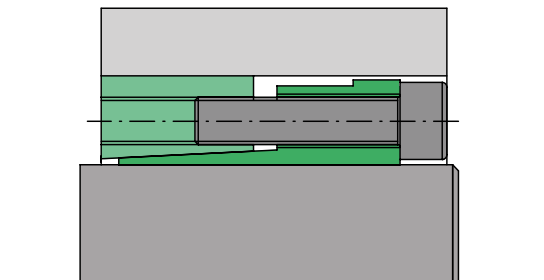

### SIT-LOCK® 5B

- Self-centering
- Low surface pressures
- Quick installation and removal
- Available for shaft diameters of 18 to 240 mm
- No axial displacement when tightening screws
- Excellent shaft-to-hub perpendicularity
- Medium to high transmissible torques

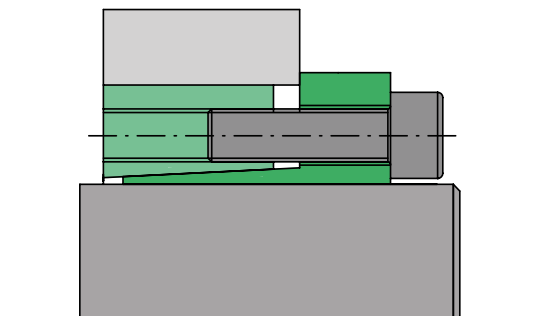

## SIT-LOCK® locking device features - internal

### SIT-LOCK® 6, SIT-LOCK® 18

- Self-centering
- SIT-LOCK® 6 available for shaft diameters of 18 to 200 mm
- SIT-LOCK® 18 available for shaft diameters of 20 to 70 mm
- Axial displacement when tightening screws
- Optimal shaft-to-hub perpendicularity
- Reduced axial dimensions
- High transmissible torques
- Quick installation and removal

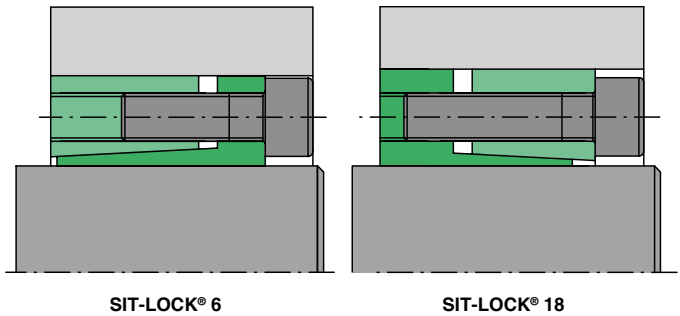

### SIT-LOCK® 7

- Self-centering
- Quick installation and removal
- Available for shaft diameters of 18 to 500 mm
- No axial displacement when tightening the screws
- Excellent concentricity and perpendicularity
- Medium to high transmissible torques

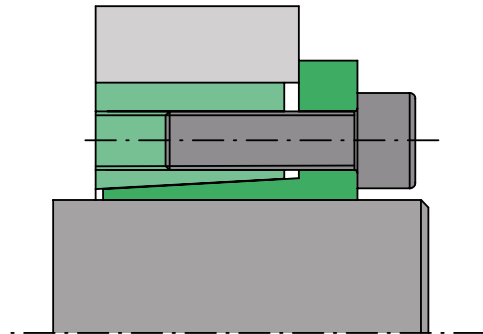

### SIT-LOCK® 8

- Self-centering
- Low surface pressures
- Quick installation and removal
- Available for shaft diameters of 14 to 50 mm
- No axial displacement when tightening the screws
- Excellent concentricity and perpendicularity
- Medium to high transmissible torques

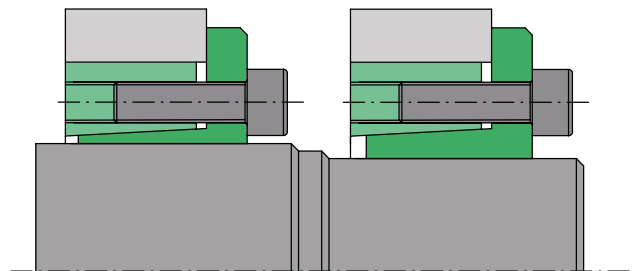

### SIT-LOCK® 12

- Self-centering
- Quick installation and removal
- Available for shaft diameters of 18 to 90 mm
- Reduced axial dimensions
- Axial displacement when tightening screws
- Excellent shaft-hub concentricity and perpendicularity
- Medium to high transmissible torques

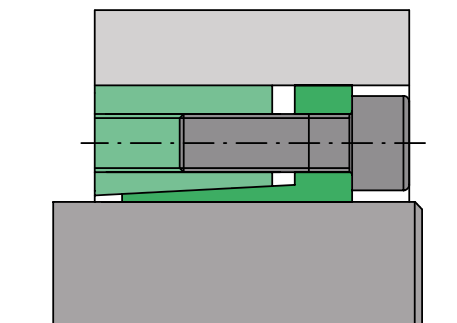

## SIT-LOCK® locking device features - internal

### SIT-LOCK® 9, SIT-LOCK® 13

- Self-centering (SIT-LOCK® 13)
- Not self-centering (SIT-LOCK® 9)
- Easy installation/removal (SIT-LOCK® 9)
- Available for shaft diameters of 14 a 70 mm
- Axial displacement when tightening the locking nut
- Good perpendicularity (SIT-LOCK® 13)
- Medium to high transmissible torques
- 

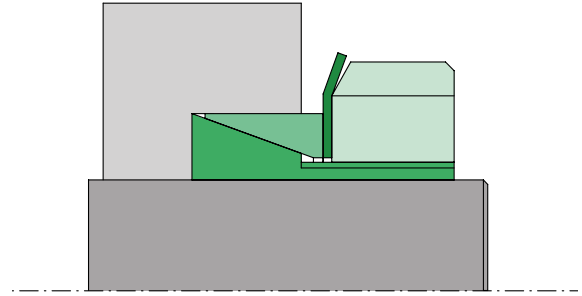

### SIT-LOCK® 15

- Self-centering
- Quick installation and removal
- Available for shaft diameters of 5 a 50 mm
- Slight axial displacement when tightening screws
- Excellent shaft-hub concentricity and perpendicularity
- Medium to high transmissible torques
- During assembly, it generates an axial force that can be used to axially clamp bearings or other components adjacent to the hub

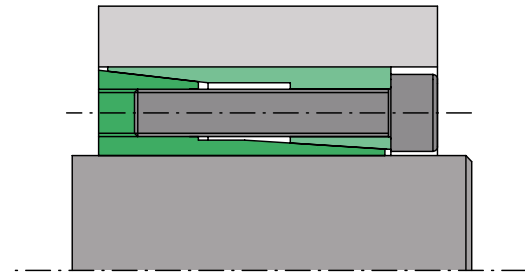

### SIT-LOCK® 1

- Not self-centering
- Easy removal
- Available for shaft diameters of 17 a 600 mm
- Long assembly times due to high number of clamping screws
- Possible use on shaft-hubs with large tolerances (h11/H11)
- Easy worldwide availability

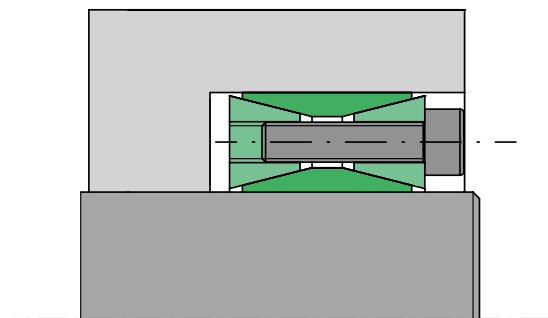

### SIT-LOCK® 2

- Not self-centering
- Requires threads in the hub
- Requires a thrust flange
- Quick installation and removal
- Available for shaft diameters of 6 a 240 mm
- No axial displacement during assembly
- Medium to low transmissible torques

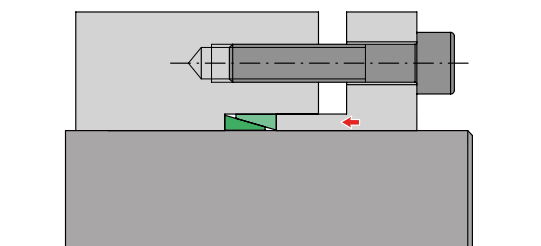

## SIT-LOCK® locking device features - internal

### SIT-LOCK® 16

- Self-centering
- Effective alternative to SIT-LOCK® 2: no flange or spacer required
- Quick installation and removal
- Available for shaft diameters of 14 to 65 mm
- Tolerance h8 for shaft, H8 for hub
- Axial displacement during assembly
- Medium to high transmissible torques
- Bolts NOT included as their length, being related to end-use, can't be set in advance

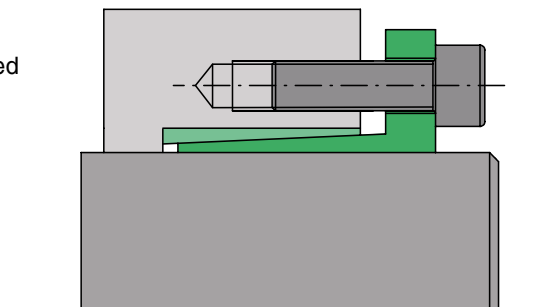

## SIT-LOCK® locking device features - rigid joint

### SIT-LOCK® 10

- Perfect axial alignment
- No backlash
- Quick installation
- Available for shaft diameters of 17 to 80 mm
- Tolerance h8 for shaft, H8 for hub
- Medium to high transmissible torques

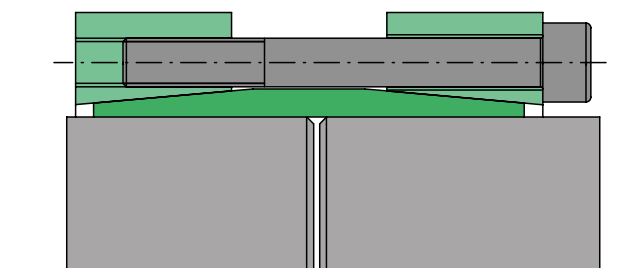

## SIT-LOCK® locking device features - shrink disc

### SIT-LOCK® 11

- Easy installation/removal
- Available for shaft diameters of 14 to 1000 mm
- High torque
- Four available versions:

SIT-LOCK® 11	standard series (recommended)
SIT-LOCK® 11 12.9	SIT-LOCK® 11 with 12.9 screws
SIT-LOCK® 11H	heavy duty series
SIT-LOCK® 11L	lightweight series

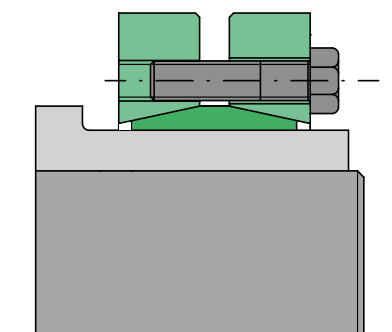

### SIT-LOCK® 14

- Quick installation/removal
- Available for shaft diameters of 12 to 1000 mm
- Very high torques
- Five available versions:

SIT-LOCK® 1422	standard series (recommended)
SIT-LOCK® 1481	SIT-LOCK® 1422 with 12.9 screws
SIT-LOCK® 1423	heavy duty series
SIT-LOCK® 1483	SIT-LOCK® 1423 with 12.9 screws
SIT-LOCK® 1421	lightweight series

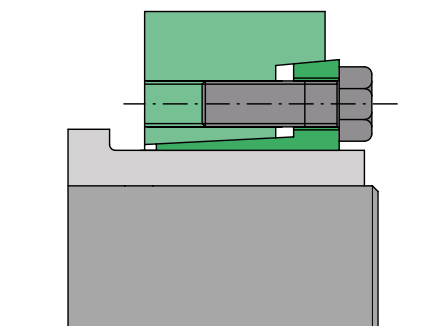

## SIT-LOCK® applications



Locking a crusher flywheel using SIT-LOCK® 4.

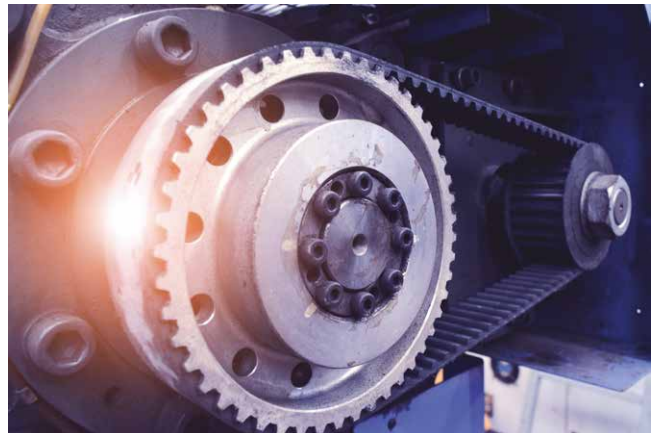

SIT-LOCK® 5A used for a timing belt pulley.



Locking two shafts using SIT-LOCK® 10, nickel-plated version.



SIT-LOCK® 1 used for a conveyor belt pulley.



Locking the drive pulley of a cable car using SIT-LOCK® 4.



SIT-LOCK® 1422 used to lock a hollow shaft.

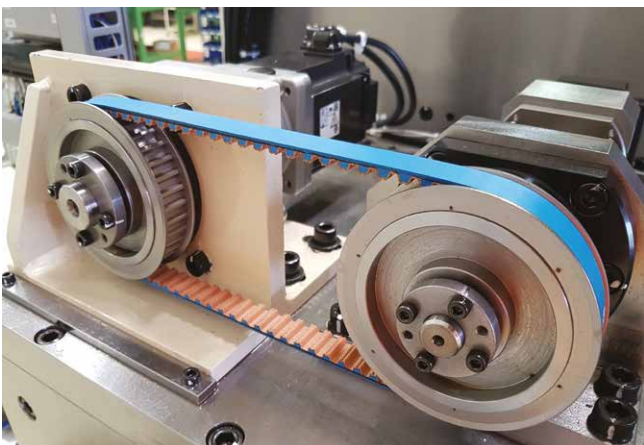

Mounting two pulleys using SIT-LOCK® 3 without spacers.



SIT-LOCK® 3 used for a disc coupling.

## SIT-LOCK® applications



Locking the hollow shaft of a planetary gearset using SIT-LOCK® 11.



Locking a bellows coupling using SIT-LOCK® 16.



MONOLOCK LOCKING DEVICE

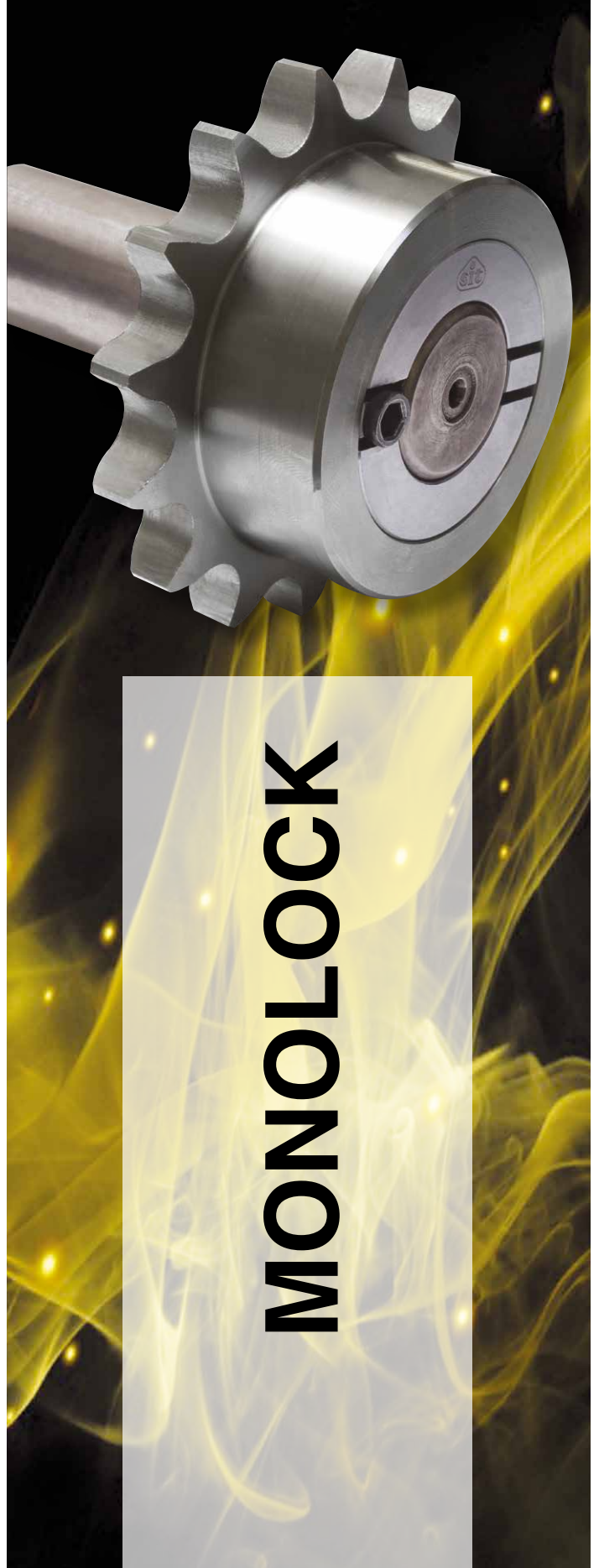

**MONOLOCK**

## SIT-LOCK® 30 MONOLOCK

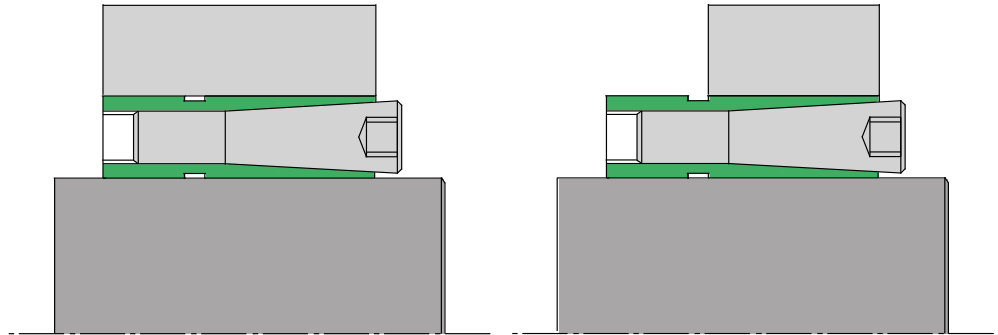

### Features

Composed of a single cylindrical ring in which a tapered hole is cut. A special screw with a tapered surface is inserted into the tapered hole. The screw is of quality 12.9 in order to allow the tightening torques indicated in the tables.

By tightening the screw to the tightening torque  $M_s$  indicated in the table, a pressure is generated on the shaft and hub. This pressure allows to transmit the torque  $M_t$  indicated in the table. The indicated  $M_t$  and  $F_{ax}$  values are valid for dry surfaces.

### Applications with simultaneous $M_t$ torque and $F_{ax}$ axial force

In applications where  $M_t$  and  $F_{ax}$  are simultaneously present, the value of transmissible torque decreases. Below is the formula for calculating the total torque:

$$M_{tam} = \sqrt{M_t^2 + \left(F_{axR} \cdot \frac{d}{2000}\right)^2}$$

$M_{tam}$  = total torque (Nm)  
 $M_t$  = required torque (Nm)  
 $F_{axR}$  = required axial force (N)  
 $d$  = shaft diameter (mm)

### Axial displacement

When tightening the screws there is no hub to shaft axial displacement.

### Surface finish

Normal surface finish is sufficient. The following values are recommended:

$$R_a \leq 3,2 \mu\text{m} - R_t \leq 16 \mu\text{m}$$

### Tolerances

The following tolerances are recommended:

shaft d h8 - hub seat D H8

For wider tolerances, please contact our Technical Department.

### Installation

Clean the inner and outer contact surfaces of the locking device, shaft and hub contact surfaces thoroughly. Remove any traces of oil from the contact surfaces of the components. Mount the shaft, hub and locking device in the desired position and then tighten the screw to the  $M_s$  torque shown in the table.

### Removal

Loosen the clamping screw. No additional operations are necessary.

### Reusing the locking device

When reusing the locking device, check all the surfaces are clean and show no obvious signs of deformation or seizing. Clean the surfaces of the locking device. Check the screw for deformation. Assemble the locking device in their original places.

### Benefits

- Quick and easy assembly and disassembly
- Quick installation and removal
- Economical
- Compact dimensions

### Recommended for the connection of:

- Timing pulleys
- Sprockets
- Levers
- Cams
- Gears

## SIT-LOCK® 30 MONOLOCK standard series

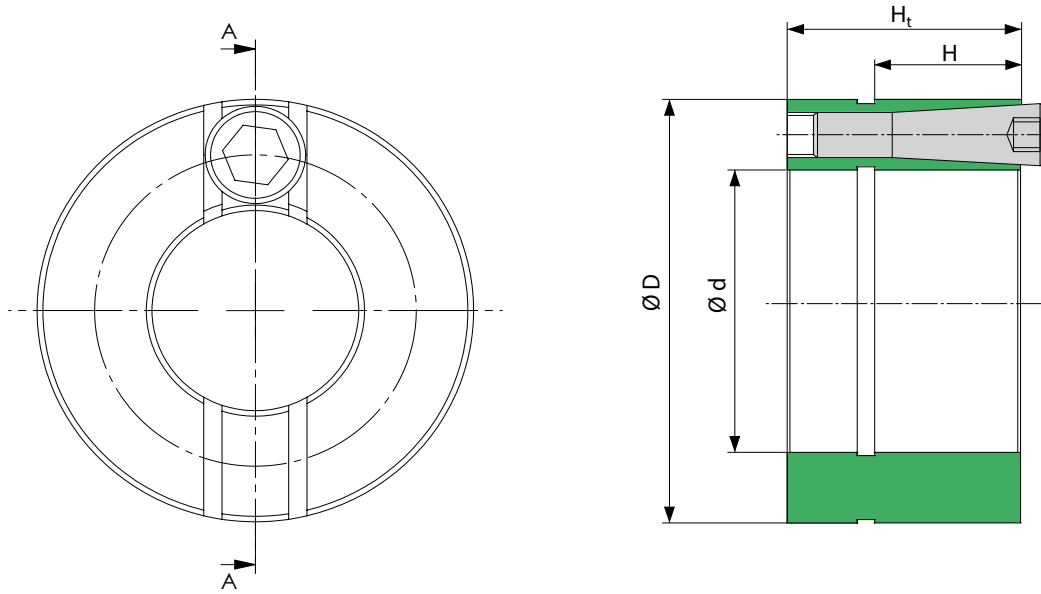

Dimensions [mm]			Clamping screws 12.9		Values with tolerances for shaft h8/hub H8	
d x D	H	H <sub>t</sub>	Type	M <sub>s</sub> [Nm]	M <sub>t</sub> [Nm]	F <sub>ax</sub> [kN]
18 x 38	20	30	M6	18	60	6,65
19 x 39	20	30	M6	18	63	6,65
20 x 40	20	30	M6	18	66	6,65
22 x 42	20	30	M6	18	73	6,65
24 x 44	20	30	M6	18	80	6,65
25 x 45	20	30	M6	18	83	6,65
28 x 48	20	30	M6	18	93	6,65
30 x 50	20	30	M6	18	100	6,65
32 x 52	20	30	M6	18	106	6,65
35 x 55	20	30	M6	18	116	6,65
38 x 58	20	30	M6	18	125	6,65
40 x 60	20	30	M6	18	133	6,65
42 x 67	25	40	M8	42	260	12,30
45 x 70	25	40	M8	42	280	12,30
48 x 73	25	40	M8	42	295	12,30
50 x 75	25	40	M8	42	310	12,30
55 x 80	25	40	M8	42	340	12,30
60 x 85	25	40	M8	42	370	12,30
65 x 90	25	40	M8	42	400	12,30

M<sub>s</sub> Screw tightening torque      Nm  
M<sub>t</sub> Transmissible torque      Nm  
F<sub>ax</sub> Transmissible axial force      kN

Internal - self-centring

## SIT-LOCK® 40 MONOLOCK special series for high torques (on request)

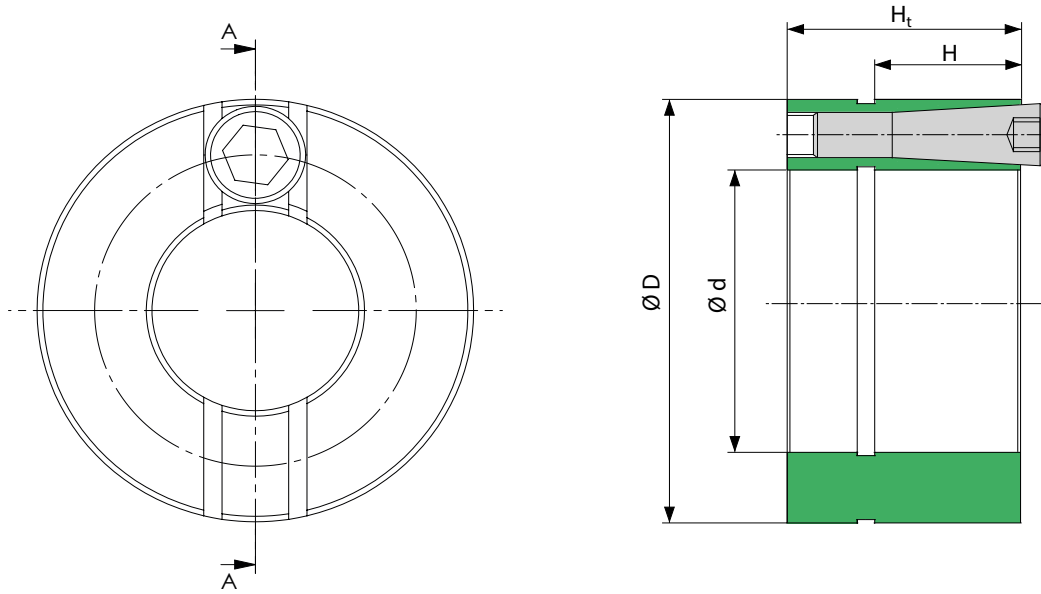

Dimensions [mm]			Clamping screws 12.9		Values with tolerances for shaft h8/hub H8	
d x D	H	H <sub>t</sub>	Type	M <sub>s</sub> [Nm]	M <sub>t</sub> [Nm]	F <sub>ax</sub> [kN]
18 x 43	25	40	M8	42	110	12,30
19 x 44	25	40	M8	42	115	12,30
20 x 45	25	40	M8	42	120	12,30
22 x 47	25	40	M8	42	130	12,30
24 x 49	25	40	M8	42	145	12,30
25 x 50	25	40	M8	42	150	12,30
28 x 53	25	40	M8	42	170	12,30
30 x 55	25	40	M8	42	180	12,30
32 x 57	25	40	M8	42	195	12,30
35 x 60	25	40	M8	42	210	12,30
38 x 63	25	40	M8	42	230	12,30
40 x 65	25	40	M8	42	240	12,30

M<sub>s</sub> Screw tightening torque  
M<sub>t</sub> Transmissible torque  
F<sub>ax</sub> Transmissible axial force

Nm  
Nm  
kN

INTERNAL LOCKING DEVICE - SELF-CENTERING

A background image showing various industrial components, including flanges and bolts, in shades of gray and white.

# INTERNAL LOCKING DEVICE SELF-CENTERING

## SIT-LOCK® 3 internal locking device - self-centering

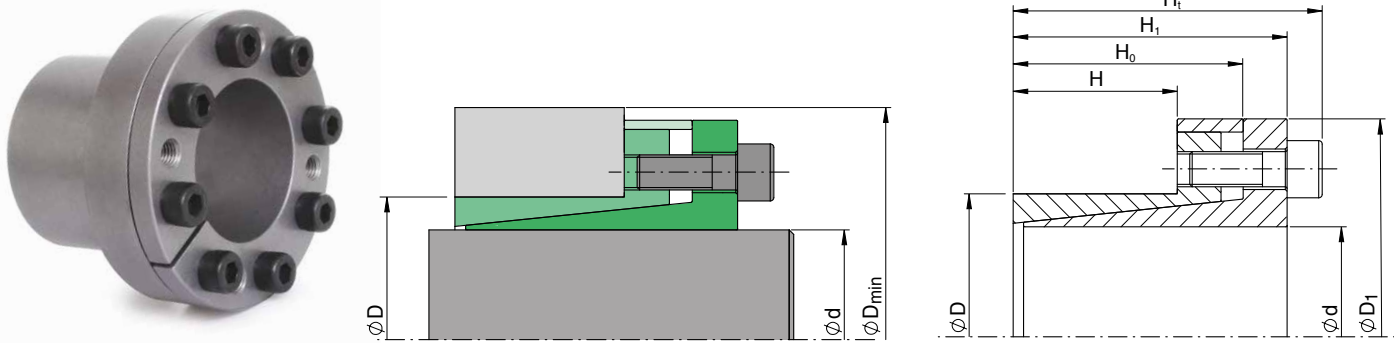

### Features

Comprised of a split inner ring and outer ring, and a spacer which prevents the hub from moving relative to the shaft when tightening the screws. This locking device is particularly suitable for applications which require low hub pressures. Recommended for use with aluminium hubs or hubs with lower mechanical properties. The table shows performance data for the following tolerances:

shaft d h8 - coupling seat on hub H8

**Do not use molybdenum disulphide-based oils or greases that reduce the coefficient of friction  $\mu$ . The values in the table are calculated with  $\mu$  0.12.**

### Hub to shaft centering

The SIT-LOCK® 3 locking device is self-centering so it does not require a centering base between the shaft and hub. This allows for hubs with reduced widths which saves on materials and leads to reduced costs.

### Installation with non-lubricated surfaces (dry)

The SIT-LOCK® 3 locking device is lubricated with oil before delivery to protect it from oxidation during storage. The values shown in the table have been calculated for applications with oiled contact surfaces. For dry installation, the values are:

$M_t, F_{ax} +5\%$

$P_w, P_n -16\%$

To get these values, the locking device must be completely disassembled and all component surfaces must be cleaned with solvent. The shaft and hub contact surfaces must also be completely clean and oil-free.

### Axial displacement

When tightening the screws there is no hub to shaft axial displacement.

### Radial loads

The SIT-LOCK® 3 locking device is suitable for applications subject to high radial loads. For further information, please contact our Technical Department.

### Surface finish

Normal surface finish is sufficient. The following values are recommended:

$R_a \leq 3,2 \mu\text{m} - R_t \leq 16 \mu\text{m}$

### SIT-LOCK® 3 applications without spacer

Using SIT-LOCK® 3 without a flange is not recommended because when the screws are being tightened, there would be a hub to shaft axial displacement. For spacer-free applications, the following installation type is recommended:

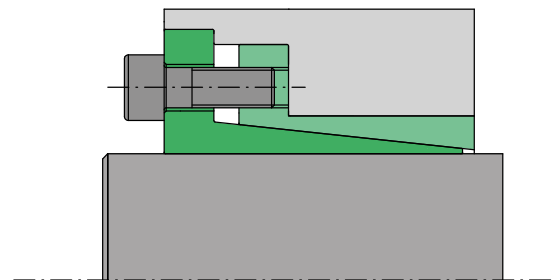

### Installation

The locking device is supplied ready to assemble. Clean the shaft contact surfaces thoroughly and apply oil. Mount the shaft, hub and locking device in the desired position.

Screw tightening sequence:

- tighten two diametrically opposed screws until the locking device surfaces make contact with the shaft and hub;
- tighten all screws to 50% of the screw tightening torque value  $M_s$  indicated in the table in a 'criss-cross' sequence;
- repeat to 100% of the  $M_s$  tightening torque indicated in the table;
- in continuous sequence, check that the tightening torque  $M_s$  has been achieved.

### Removal

Gradually loosen the clamping screws. Remove the clamping screws and insert them into the special removal threads on the inner ring flange. Tighten the screws in a 'criss-cross' sequence until the locking device is released.

## SIT-LOCK® 3 internal locking device - self-centering

Dimensions [mm]						Clamping screws DIN 912 12.9			Values with tolerances for shaft h8/hub H8			
d x D	H	H <sub>0</sub>	H <sub>1</sub>	H <sub>t</sub>	D <sub>1</sub>	Type	N°	M <sub>s</sub> [Nm]	M <sub>t</sub> [Nm]	F <sub>ax</sub> [kN]	P <sub>w</sub> [N/mm <sup>2</sup> ]	P <sub>n</sub> [N/mm <sup>2</sup> ]
6 x 14	10	18,5	21	24	25	M3	3	2,2	12,6	4,2	186	80
7 x 15	12	22	25	29	27	M4	3	4,9	25,9	7,4	234	110
8 x 15	12	22	25	29	27	M4	3	4,9	29,6	7,4	204	110
9 x 16	14	23	26	30	28	M4	4	4,9	44,6	10	208	115
10 x 16	14	23	26	30	28	M4	4	4,9	50	10	187	115
11 x 18	14	23	26	30	32	M4	4	4,9	54	10	170	105
12 x 18	14	23	26	30	32	M4	4	4,9	59	10	156	105
13 x 23	14	23	26	30	38	M4	4	4,9	64	10	144	80
14 x 23	14	23	26	30	38	M4	4	4,9	69	10	134	80
15 x 24	16	29	36	42	45	M6	3	17	128	17	189	120
16 x 24	16	29	36	42	45	M6	3	17	137	17	177	120
17 x 26	18	31	38	44	47	M6	4	17	193	23	197	130
18 x 26	18	31	38	44	47	M6	4	17	204	23	186	130
19 x 27	18	31	38	44	49	M6	4	17	216	23	176	125
20 x 28	18	31	38	44	50	M6	4	17	227	23	168	120
22 x 32	25	38	45	51	54	M6	4	17	250	23	110	75
24 x 34	25	38	45	51	56	M6	4	17	272	23	101	70
25 x 34	25	38	45	51	56	M6	4	17	284	23	97	70
28 x 39	25	38	45	51	61	M6	6	17	477	34	129	95
30 x 41	25	38	45	51	62	M6	6	17	512	34	121	90
32 x 43	25	38	45	51	65	M6	6	17	546	34	113	85
35 x 47	32	45	52	58	69	M6	8	17	796	46	108	80
38 x 50	32	45	52	58	72	M6	8	17	865	46	99	75
40 x 53	32	45	52	58	75	M6	8	17	910	46	94	70
42 x 55	32	45	52	58	78	M6	8	17	956	46	90	70
45 x 59	45	62	70	78	86	M8	8	41	1.890	84	110	85
48 x 62	45	62	70	78	87	M8	8	41	2.016	84	103	80
50 x 65	45	62	70	78	92	M8	8	41	2.100	84	99	75
55 x 71	55	72	80	88	98	M8	9	41	2.599	95	83	65
60 x 77	55	72	80	88	104	M8	9	41	2.835	95	76	60
65 x 84	55	72	80	88	111	M8	9	41	3.071	95	70	55
70 x 90	65	86	96	106	119	M10	9	83	5.254	150	88	70
75 x 95	65	86	96	106	126	M10	9	83	5.629	150	82	65
80 x 100	65	86	96	106	131	M10	12	83	8.008	200	102	80
85 x 106	65	86	96	106	137	M10	12	83	8.509	200	96	75
90 x 112	65	86	96	106	144	M10	12	83	9.009	200	91	75
95 x 120	65	86	96	106	149	M10	14	83	11.091	234	100	80
100 x 125	65	86	96	106	154	M10	18	83	15.010	300	123	100
110 x 140	90	114	128	140	180	M12	12	145	16.027	291	78	60
120 x 155	90	114	128	140	198	M12	12	145	17.484	291	72	55
130 x 165	90	114	128	140	208	M12	16	145	25.259	389	88	70

M<sub>s</sub> Screw tightening torque                      Nm  
M<sub>t</sub> Transmissible torque                              Nm  
F<sub>ax</sub> Transmissible axial force                      kN  
P<sub>w</sub> Pressure on shaft                                    N/mm<sup>2</sup>  
P<sub>n</sub> Pressure on hub                                        N/mm<sup>2</sup>

**IMPORTANT:** The screw tightening torque M<sub>s</sub> can be reduced by 40% of the value indicated in the table. M<sub>t</sub>, F<sub>ax</sub>, P<sub>w</sub>, P<sub>n</sub> decrease proportionally.

For further information or in case of needs of diameters or dimensions different to those in the table, please contact our Technical Department.

Internal - self-centering

## SIT-LOCK® 20 internal locking device - self-centering

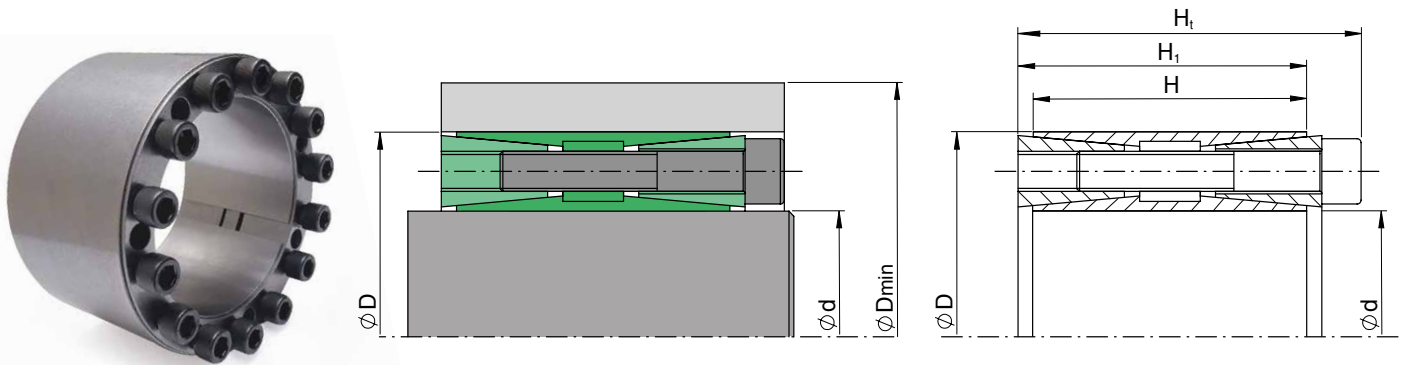

### Features

Composed of two tapered rings, a cut inner ring, a cut outer ring and an intermediate ring for the extraction process. **Particularly suitable for applications where high torques need to be transmitted. Compared to SIT-LOCK® 4, the pressure distribution is optimised, ensuring an even load on the entire surface of the inner and outer ring.** In addition, sliding takes place entirely within the cones, eliminating the influence of shaft roughness and ensuring greater positioning accuracy. The table shows performance data for the following tolerances:

shaft d h8 – coupling seat on hub H8

**Do not use molybdenum disulphide-based oils or greases that reduce the coefficient of friction  $\mu$ . The values in the table are calculated with  $\mu$  0.12**

### Hub to shaft centering

The SIT-LOCK® 20 locking device is self-centring so it does not require a centring base between the shaft and the hub. This allows for hubs with reduced widths which saves on materials and leads to reduced costs.

### Installation with non-lubricated surfaces (dry)

The SIT-LOCK® 20 locking device is lubricated with oil before delivery to protect it from oxidation during storage. The values shown in the table have been calculated for applications with oiled contact surfaces. For dry installation, the values are:

$$M_t, F_{ax} +5\%$$

$$P_w, P_n -16\%$$

To get these values, the locking device must completely disassembled and all component surfaces must be cleaned with solvent. The shaft and hub contact surfaces must also be completely dry.

### Axial displacement

**When tightening screws, the hub maintains perfect axial stability in relation to the shaft, eliminating any unwanted displacement.** This feature makes it ideal for application on helical and bi-helical gears, ensuring maximum precision and operational reliability.

### Surface finish

Normal surface finish is sufficient. The following values are recommended:  $R_a \leq 3,2 \mu m$  -  $R_t \leq 16 \mu m$

### Radial loads

The SIT-LOCK® 20 locking device is suitable for high radial loads. For further information, please contact our Technical Department.

### Applications with more than one SIT-LOCK® 20 device

Where two SIT-LOCK® 20 locking devices are mounted in a row, the total transmissible torque  $M_t$  is:

$$1 \text{ device } M_t = M_t \text{ indicated in catalogue}$$

$$2 \text{ device } M_t = M_t \text{ indicated in catalogue} \cdot 1,9$$

### Installation

The locking device is supplied ready to assemble. Clean the shaft contact surfaces thoroughly and apply oil. Mount the shaft, hub and locking device in the desired position.

Screw tightening sequence:

- tighten four screws crosswise until the locking device surfaces make contact with the shaft and hub;
- tighten all screws to 50% of the screw tightening torque value  $M_s$  indicated in the table in a 'criss-cross' sequence;
- repeat to 100% of the  $M_s$  tightening torque indicated in the table;
- in continuous sequence, check that the tightening torque  $M_s$  has been achieved. Installation is complete when all screws are tightened to the  $M_s$  tightening torque indicated in the table.

### Removal

- gradually loosen the clamping screws and remove them from the locking device;
- insert the screws into the front tapered bush removal threads and tighten them in a 'criss-cross' sequence until the front cone is completely removed. Do not tighten the screws to a value greater than the  $M_s$  tightening torque indicated in the table;
- insert the screws into the extraction threads in the intermediate ring and tighten them in a criss-cross sequence until the rear cone is completely disassembled. Do not tighten the screws to a value greater than the  $M_s$  tightening torque indicated in the table.

### Reusing the locking device

When reusing the locking device, check all the surface are clean and show no obvious signs of deformation or seizing. Oil all surfaces and threads. Check the screws have not been deformed. Oil the screws and instal the components in their original places.

## SIT-LOCK® 20 internal locking device - self-centering

Dimensions [mm]				Clamping screws DIN 912 12.9			Values with tolerances for shaft h8/hub H8			
d x D	H	H <sub>1</sub>	H <sub>t</sub>	Type	N°	M <sub>s</sub> [Nm]	M <sub>t</sub> [Nm]	F <sub>ax</sub> [kN]	P <sub>w</sub> [N/mm <sup>2</sup> ]	P <sub>n</sub> [N/mm <sup>2</sup> ]
45 x 75	56	64	72	M8	8	41	3.492	155	163	100
48 x 80	56	64	72	M8	8	41	3.725	155	153	90
50 x 80	56	64	72	M8	8	41	3.880	155	147	90
55 x 85	56	64	72	M8	8	41	4.268	155	134	85
60 x 90	56	64	72	M8	10	41	5.820	194	153	100
65 x 95	56	64	72	M8	10	41	6.305	194	141	95
70 x 110	70	78	88	M10	10	83	10.784	308	167	105
75 x 115	70	78	88	M10	10	83	11.554	308	156	100
80 x 120	70	78	88	M10	12	83	14.788	370	175	115
85 x 125	70	78	88	M10	12	83	15.712	370	165	110
90 x 130	70	78	88	M10	12	83	16.637	370	156	110
95 x 135	70	78	88	M10	12	83	17.561	370	147	105
100 x 145	90	100	112	M12	12	145	26.915	538	159	110
110 x 155	90	100	112	M12	12	145	29.607	538	144	100
120 x 165	90	100	112	M12	14	145	37.680	628	154	110
130 x 180	104	116	130	M14	12	230	48.009	739	145	105
140 x 190	104	116	130	M14	14	230	60.319	862	157	115
150 x 200	104	116	130	M14	16	230	73.860	985	167	125
160 x 210	104	116	130	M14	16	230	78.784	985	157	120
170 x 225	134	146	162	M16	14	355	101.796	1.198	139	105
180 x 235	134	146	162	M16	16	355	123.174	1.369	151	115
190 x 250	134	146	162	M16	16	355	130.017	1.369	143	110
200 x 260	134	146	162	M16	16	355	136.860	1.369	135	105
220 x 285	134	146	162	M16	20	355	188.188	1.711	154	120
240 x 305	134	146	162	M16	22	355	225.828	1.882	155	120
260 x 325	134	146	162	M16	22	355	244.647	1.882	143	115
280 x 355	165	177	197	M20	20	690	373.870	2.671	153	120
300 x 375	165	177	197	M20	22	690	440.640	2.938	157	125
320 x 405	165	177	197	M20	22	690	470.016	2.938	148	115
340 x 425	165	177	197	M20	24	690	544.782	3.205	152	120
360 x 455	190	202	224	M22	22	930	658.206	3.657	142	110
380 x 475	190	202	224	M22	26	930	821.085	4.322	159	125
400 x 495	190	202	224	M22	26	930	864.300	4.322	151	120

M <sub>s</sub>	Screw tightening torque	Nm
M <sub>t</sub>	Transmissible torque	Nm
F <sub>ax</sub>	Transmissible axial force	kN
P <sub>w</sub>	Pressure on shaft	N/mm <sup>2</sup>
P <sub>n</sub>	Pressure on hub	N/mm <sup>2</sup>

**IMPORTANT:** The screw tightening torque M<sub>s</sub> can be reduced by 40% of the value indicated in the table. M<sub>t</sub>, F<sub>ax</sub>, P<sub>w</sub>, P<sub>n</sub> decrease proportionally.

For further information or in case of needs of diameters or dimensions different to those in the table, please contact our Technical Department.

Internal - self-centring

## SIT-LOCK® 4 internal locking device - self-centering

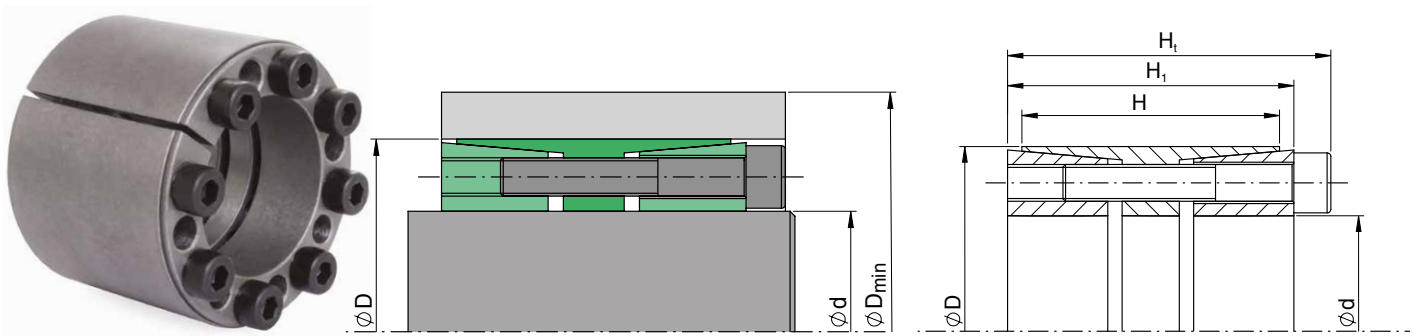

### Features

Composed of two tapered rings and one outer ring with a split. It is particularly suitable for applications that require high torque transmission. The table shows performance data for the following tolerances:

shaft d h8 - coupling seat on hub H8

**Do not use molybdenum disulphide-based oils or greases that reduce the coefficient of friction  $\mu$ . The values in the table are calculated with  $\mu$  0.12.**

### Hub to shaft centering

The SIT-LOCK® 4 locking device is self-centering so it does not require a centering base between the shaft and hub. This allows for hubs with reduced widths which saves on materials and leads to reduced costs.

### Installation with non-lubricated surfaces (dry)

The SIT-LOCK® 4 locking device is lubricated with oil before delivery to protect it from oxidation during storage. The values shown in the table have been calculated for applications with oiled contact surfaces. For dry installation, the values are:

$M_t, F_{ax} +5\%$

$P_w, P_n -16\%$

To get these values, the locking device must be completely disassembled and all component surfaces must be cleaned with solvent. The shaft and hub contact surfaces must also be completely dry.

### Axial displacement

When tightening the screws there is no hub to shaft axial displacement.

### Radial loads

The SIT-LOCK® 4 locking device is suitable for high radial loads. For further information, please contact our Technical Department.

### Surface finish

Normal surface finish is sufficient. The following values are recommended:

$R_a \leq 3,2 \mu\text{m} - R_t \leq 16 \mu\text{m}$

### Applications with more than one SIT-LOCK® 4 device

Where two SIT-LOCK® 4 locking devices are mounted in a row, the total transmissible torque  $M_t$  is:

1 device  $M_t = M_t$  indicated in catalogue

2 devices  $M_t = M_t$  indicated in catalogue  $\cdot 1.9$

### Installation

The locking device is supplied ready to assemble. Clean the shaft contact surfaces thoroughly and apply oil. Mount the shaft, hub and locking device in the desired position.

Screw tightening sequence:

- tighten four screws crosswise until the locking device surfaces make contact with the shaft and hub;
- tighten all screws to 50% of the screw tightening torque value  $M_s$  indicated in the table in a 'criss-cross' sequence;
- repeat to 100% of the  $M_s$  tightening torque indicated in the table;
- in continuous sequence, check that the tightening torque  $M_s$  has been achieved. Installation is complete when all screws are tightened to the  $M_s$  tightening torque indicated in the table.

### Removal

- gradually loosen the clamping screws and remove them from the locking device;
- insert the screws into the front tapered bush removal threads and tighten them in a 'criss-cross' sequence until the front cone is completely removed. Do not tighten the screws to a value greater than the  $M_s$  tightening torque indicated in the table;
- insert the screws into the extraction threads of the outer ring's central flange and tighten them in a 'criss-cross' sequence until the rear tapered bush is fully removed. Do not tighten the screws to a value greater than the  $M_s$  tightening torque indicated in the table.

### Reusing the locking device

When reusing the locking device, check all the surfaces are clean and show no obvious signs of deformation or seizing. Oil all surfaces and threads. Check the screws have not been deformed. Oil the screws and reinstall the components in their original places.

## SIT-LOCK® 4 internal locking device - self-centering

Dimensions [mm]				Clamping screws DIN 912 12.9			Values with tolerances for shaft h8/hub H8			
d x D	H	H <sub>1</sub>	H <sub>t</sub>	Type	N°	M <sub>s</sub> [Nm]	M <sub>t</sub> [Nm]	F <sub>ax</sub> [kN]	P <sub>w</sub> [N/mm <sup>2</sup> ]	P <sub>n</sub> [N/mm <sup>2</sup> ]
25 x 50	41	45	51	M6	6	17	853	68	207	90
28 x 55	41	45	51	M6	8	17	1.274	91	246	105
30 x 55	41	45	51	M6	8	17	1.365	91	230	105
35 x 60	41	45	51	M6	8	17	1.593	91	197	100
38 x 65	41	45	51	M6	8	17	1.729	91	181	90
40 x 65	41	45	51	M6	10	17	2.274	114	215	115
42 x 75	41	45	53	M8	8	41	3.530	168	322	145
45 x 75	41	45	53	M8	8	41	3.782	168	300	145
48 x 80	58	62	70	M8	8	41	4.034	168	186	95
50 x 80	58	62	70	M8	8	41	4.203	168	178	95
55 x 85	58	62	70	M8	8	41	4.623	168	162	90
60 x 90	58	62	70	M8	10	41	6.303	210	186	105
65 x 95	58	62	70	M8	10	41	6.828	210	171	100
70 x 110	70	76	86	M10	10	83	11.676	334	211	115
75 x 115	70	76	86	M10	10	83	12.510	334	197	110
80 x 120	70	76	86	M10	12	83	16.012	400	221	125
85 x 125	70	76	86	M10	12	83	17.013	400	208	120
90 x 130	70	76	86	M10	12	83	18.014	400	197	115
95 x 135	70	76	86	M10	12	83	19.014	400	186	110
100 x 145	92	98	110	M12	12	145	29.145	583	193	115
110 x 155	92	98	110	M12	12	145	32.060	583	176	110
120 x 165	92	98	110	M12	14	145	40.800	680	188	120
130 x 180	108	114	128	M14	12	230	51.981	800	174	110
140 x 190	108	114	128	M14	14	230	65.310	933	188	120
150 x 200	108	114	128	M14	16	230	79.973	1.066	201	130
160 x 210	108	114	128	M14	16	230	85.304	1.066	188	125
170 x 225	136	146	162	M16	14	355	110.228	1.297	169	110
180 x 235	136	146	162	M16	16	355	133.380	1.482	182	125
190 x 250	136	146	162	M16	16	355	140.790	1.482	172	115
200 x 260	136	146	162	M16	16	355	148.200	1.482	164	110
220 x 285	136	146	162	M16	20	355	203.775	1.853	186	125
240 x 305	136	146	162	M16	22	355	244.536	2.038	188	130
260 x 325	136	146	162	M16	22	355	264.914	2.038	173	120
280 x 355	165	177	197	M20	20	690	404.838	2.892	189	130
300 x 375	165	177	197	M20	22	690	477.135	3.181	194	135
320 x 405	165	177	197	M20	22	690	508.944	3.181	182	125
340 x 425	165	177	197	M20	24	690	589.917	3.470	187	130
360 x 455	188	202	224	M22	22	930	712.728	3.960	176	125
380 x 475	188	202	224	M22	26	930	889.105	4.680	197	140
400 x 495	188	202	224	M22	26	930	935.900	4.680	187	135

M<sub>s</sub> Screw tightening torque Nm  
M<sub>t</sub> Transmissible torque Nm  
F<sub>ax</sub> Transmissible axial force kN  
P<sub>w</sub> Pressure on shaft N/mm<sup>2</sup>  
P<sub>n</sub> Pressure on hub N/mm<sup>2</sup>

**IMPORTANT:** The screw tightening torque M<sub>s</sub> can be reduced by 40% of the value indicated in the table. M<sub>t</sub>, F<sub>ax</sub>, P<sub>w</sub>, P<sub>n</sub> decrease proportionally.

For further information or in case of needs of diameters or dimensions different to those in the table, please contact our Technical Department.

Internal - self-centering

## SIT-LOCK® 4A internal locking device - self-centering

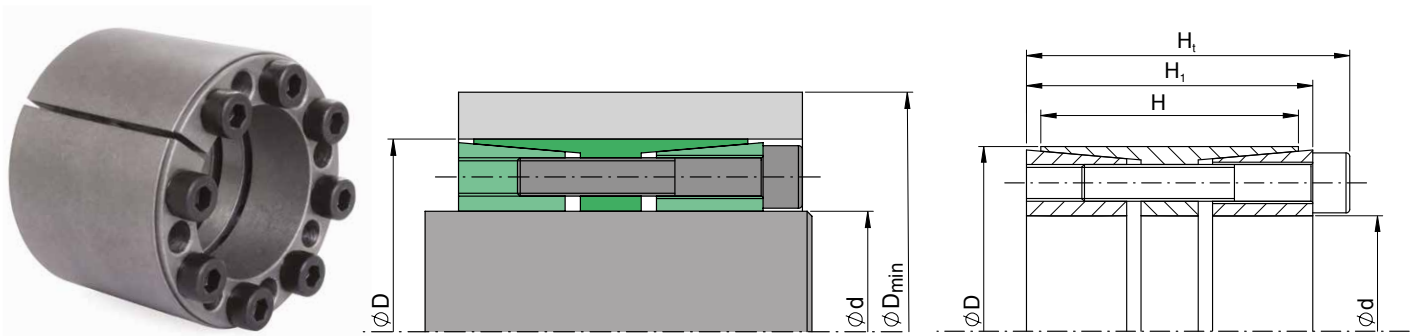

### Features

Composed of two tapered rings and one outer ring with a split. It is particularly suitable for applications that require high torque transmission. The table shows performance data for the following tolerances:

shaft  $d$  h8 - coupling seat on hub H8

**Do not use molybdenum disulphide-based oils or greases that reduce the coefficient of friction  $\mu$ . The values in the table are calculated with  $\mu$  0.12.**

### Hub to shaft centering

The SIT-LOCK® 4A locking device is self-centering so it does not require a centering base between the shaft and hub. This allows for hubs with reduced widths which saves on materials and leads to reduced costs.

### Installation with non-lubricated surfaces (dry)

The SIT-LOCK® 4A locking device is lubricated with oil before delivery to protect it from oxidation during storage. The values shown in the table have been calculated for applications with oiled contact surfaces. For dry installation, the values are:

$M_t, F_{ax} +5\%$

$P_w, P_n -16\%$

To get these values, the locking device must be completely disassembled and all component surfaces must be cleaned with solvent. The shaft and hub contact surfaces must also be completely dry.

### Axial displacement

When tightening the screws there is no hub to shaft axial displacement.

### Radial loads

The SIT-LOCK® 4A locking device is suitable for high radial loads. For further information, please contact our Technical Department.

### Surface finish

Normal surface finish is sufficient. The following values are recommended:

$R_a \leq 3,2 \mu\text{m} - R_t \leq 16 \mu\text{m}$

### Applications with more than one SIT-LOCK® 4A device

Where two SIT-LOCK® 4A locking devices are mounted in a row, the total transmissible torque  $M_t$  is:

2 devices  $M_t = M_t$  indicated in catalogue  $\cdot 1,9$

### Installation

The locking device is supplied ready to assemble. Clean the shaft contact surfaces thoroughly and apply oil. Mount the shaft, hub and locking device in the desired position.

Screw tightening sequence:

- tighten four screws crosswise until the locking device surfaces make contact with the shaft and hub;
- tighten all screws to 50% of the screw tightening torque value  $M_s$  indicated in the table in a 'criss-cross' sequence;
- repeat to 100% of the  $M_s$  tightening torque indicated in the table;
- in continuous sequence, check that the tightening torque  $M_s$  has been achieved. Installation is complete when all screws are tightened to the  $M_s$  tightening torque indicated in the table.
- 

### Removal

- gradually loosen the clamping screws and remove them from the locking device;
- insert the screws into the front tapered bush removal threads and tighten them in a 'criss-cross' sequence until the front tapered bush is completely removed. Do not tighten the screws to a value greater than the  $M_s$  tightening torque indicated in the table;
- insert the screws into the extraction threads of the outer ring's central flange and tighten them in a 'criss-cross' sequence until the rear tapered bush is fully removed. Do not tighten the screws to a value greater than the  $M_s$  tightening torque indicated in the table.

### Reusing the locking device

When reusing the locking device, check all the surfaces are clean and show no obvious signs of deformation or seizing. Oil all surfaces and the inside of the threads. Check the screws have not been deformed. Oil the screws and reinstall the components in their original places.

## SIT-LOCK® 4A internal locking device - self-centering

Dimensions [mm]				Clamping screws DIN 912 12.9			Values with tolerances for shaft h8/hub H8			
d x D	H	H <sub>1</sub>	H <sub>t</sub>	Type	N°	M <sub>s</sub> [Nm]	M <sub>t</sub> [Nm]	F <sub>ax</sub> [kN]	P <sub>w</sub> [N/mm <sup>2</sup> ]	P <sub>n</sub> [N/mm <sup>2</sup> ]
25 x 55	32	40	46	M6	6	17	853	68	278	105
28 x 55	32	40	46	M6	6	17	955	68	249	105
30 x 55	32	40	46	M6	6	17	1.023	68	232	105
35 x 60	44	54	60	M6	7	17	1.393	80	159	80
38 x 75	44	54	62	M8	7	41	2.795	147	285	120
40 x 75	44	54	62	M8	7	41	2.942	147	271	120
42 x 75	44	54	62	M8	7	41	3.089	147	258	120
45 x 75	44	54	62	M8	7	41	3.310	147	241	120
48 x 80	56	64	72	M8	8	41	4.034	168	194	100
50 x 80	56	64	72	M8	8	41	4.203	168	186	100
55 x 85	56	64	72	M8	9	41	5.200	189	190	105
60 x 90	56	64	72	M8	10	41	6.303	210	194	110
65 x 95	56	64	72	M8	10	41	6.828	210	179	105

From diameters of 70 mm, SIT-LOCK® 4A is the same as SIT-LOCK® 4.  
For SIT-LOCK® 4 dimensions and performance, refer to the table on page 25.

M <sub>s</sub>	Screw tightening torque	Nm
M <sub>t</sub>	Transmissible torque	Nm
F <sub>ax</sub>	Transmissible axial force	kN
P <sub>w</sub>	Pressure on shaft	N/mm <sup>2</sup>
P <sub>n</sub>	Pressure on hub	N/mm <sup>2</sup>

**IMPORTANT:** The screw tightening torque M<sub>s</sub> can be reduced by 40% of the value indicated in the table. M<sub>t</sub>, F<sub>ax</sub>, P<sub>w</sub>, P<sub>n</sub> decrease proportionally.

For further information or in case of needs of diameters or dimensions different to those in the table, please contact our Technical Department.

## SIT-LOCK® 4C internal locking device - self-centering

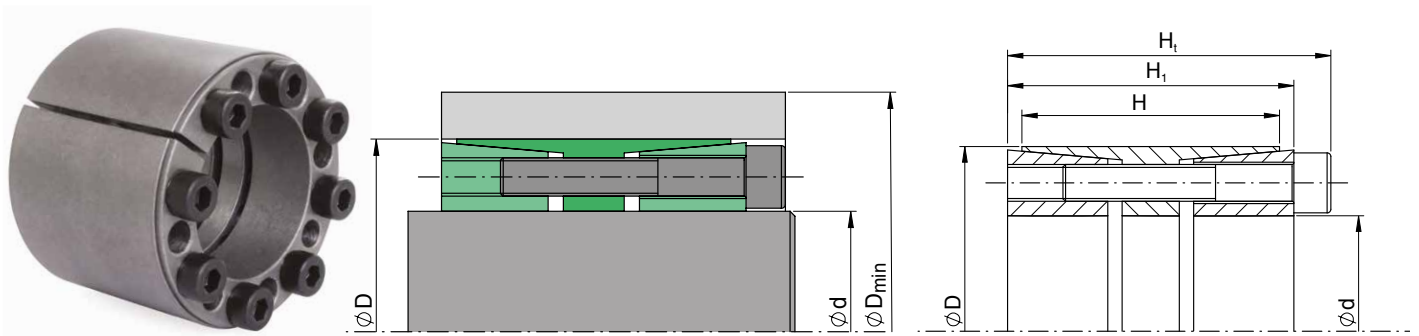

### Features

Composed of two tapered rings and one outer ring with a split. It is particularly suitable for applications that require high torque transmission. The table shows performance data for the following tolerances:

shaft d h8 - coupling seat on hub H8

**Do not use molybdenum disulphide-based oils or greases that reduce the coefficient of friction  $\mu$ . The values in the table are calculated with  $\mu$  0.12.**

### Hub to shaft centering

The SIT-LOCK® 4C locking device is self-centering so it does not require a centering base between the shaft and hub. This allows for hubs with reduced widths which saves on materials and leads to reduced costs.

### Installation with non-lubricated surfaces (dry)

The SIT-LOCK® 4C locking device is lubricated with oil before delivery to protect it from oxidation during storage. The values shown in the table have been calculated for applications with oiled contact surfaces. For dry installation, the values are:

$M_t, F_{ax} +5\%$

$P_w, P_n -16\%$

To get these values, the locking device must be completely disassembled and all component surfaces must be cleaned with solvent. The shaft and hub contact surfaces must also be completely dry.

### Axial displacement

When tightening the screws there is no hub to shaft axial displacement.

### Radial loads

The SIT-LOCK® 4C locking device is suitable for high radial loads. For further information, please contact our Technical Department.

### Surface finish

Normal surface finish is sufficient. The following values are recommended:

$R_a \leq 3,2 \mu\text{m} - R_t \leq 16 \mu\text{m}$

### Applications with more than one SIT-LOCK® 4C device

Where two SIT-LOCK® 4C locking devices are mounted in a row, the total transmissible torque  $M_t$  is:

2 devices  $M_t = M_t$  indicated in catalogue  $\cdot 1,9$

### Installation

The locking device is supplied ready to assemble. Clean the shaft contact surfaces thoroughly and apply oil. Mount the shaft, hub and locking device in the desired position.

Screw tightening sequence:

- tighten four screws crosswise until the locking device surfaces make contact with the shaft and hub;
- tighten all screws to 50% of the screw tightening torque value  $M_s$  indicated in the table in a 'criss-cross' sequence;
- repeat to 100% of the  $M_s$  tightening torque indicated in the table;
- in continuous sequence, check that the tightening torque  $M_s$  has been achieved. Installation is complete when all screws are tightened to the  $M_s$  tightening torque indicated in the table.
- 

### Removal

- gradually loosen the clamping screws and remove them from the locking device;
- insert the screws into the front tapered bush removal threads and tighten them in a 'criss-cross' sequence until the front tapered bush is completely removed. Do not tighten the screws to a value greater than the  $M_s$  tightening torque indicated in the table;
- insert the screws into the extraction threads of the outer ring's central flange and tighten them in a 'criss-cross' sequence until the rear tapered bush is fully removed. Do not tighten the screws to a value greater than the  $M_s$  tightening torque indicated in the table.

### Reusing the locking device

When reusing the locking device, check all the surfaces are clean and show no obvious signs of deformation or seizing. Oil all surfaces and the inside of the threads. Check the screws have not been deformed. Oil the screws and reinstall the components in their original places.

## SIT-LOCK® 4C internal locking device - self-centering

Dimensions [mm]				Clamping screws DIN 912 12.9			Values with tolerances for shaft h8/hub H8			
d x D	H	H <sub>1</sub>	H <sub>t</sub>	Type	N°	M <sub>s</sub> [Nm]	M <sub>t</sub> [Nm]	F <sub>ax</sub> [kN]	P <sub>w</sub> [N/mm <sup>2</sup> ]	P <sub>n</sub> [N/mm <sup>2</sup> ]
70 x 110	50	60	70	M10	8	83	7.158	205	194	100
75 x 115	50	60	70	M10	8	83	7.669	205	181	95
80 x 120	50	60	70	M10	10	83	10.224	256	212	115
85 x 125	50	60	70	M10	10	83	10.863	256	199	110
90 x 130	50	60	70	M10	11	83	12.650	281	207	115
95 x 135	50	60	70	M10	11	83	13.352	281	196	110
100 x 145	60	70	82	M12	10	145	18.605	372	206	115
110 x 155	60	70	82	M12	10	145	20.466	372	187	105
120 x 165	60	70	82	M12	11	145	24.558	409	189	110
130 x 180	65	79	91	M12	14	145	33.865	521	201	120
140 x 190	65	79	91	M12	15	145	39.074	558	200	120
150 x 200	65	79	91	M12	15	145	41.865	558	186	115
160 x 210	65	79	91	M12	16	145	47.632	595	186	115
170 x 225	78	92	106	M14	15	230	65.102	766	187	115
180 x 235	78	92	106	M14	15	230	68.931	766	176	110
190 x 250	88	102	116	M14	16	230	77.606	817	154	100
200 x 260	88	102	116	M14	18	230	91.900	919	165	105
220 x 285	96	111	127	M16	15	355	117.084	1.064	160	105
240 x 305	96	111	127	M16	20	355	170.304	1.419	196	130
260 x 325	96	111	127	M16	20	355	184.496	1.419	181	120
280 x 355	96	111	131	M20	15	690	232.610	1.662	207	130
300 x 375	96	111	131	M20	16	690	265.845	1.772	206	130
320 x 405	124	136	156	M20	20	690	354.464	2.215	177	115
340 x 425	124	136	156	M20	20	690	376.618	2.215	166	110
360 x 455	140	155	177	M22	20	930	496.386	2.758	172	115
380 x 475	140	155	177	M22	20	930	523.963	2.758	163	110
400 x 495	140	155	177	M22	22	930	606.700	3.034	170	115
420 x 515	140	155	177	M22	24	930	694.932	3.309	177	120
440 x 535	140	155	177	M22	24	930	728.024	3.309	169	115
460 x 555	140	155	177	M22	24	930	761.116	3.309	162	115
480 x 575	140	155	177	M22	25	930	827.304	3.447	161	115
500 x 595	140	155	177	M22	25	930	861.775	3.447	155	110

M<sub>s</sub> Screw tightening torque                      Nm  
M<sub>t</sub> Transmissible torque                              Nm  
F<sub>ax</sub> Transmissible axial force                      kN  
P<sub>w</sub> Pressure on shaft                                  N/mm<sup>2</sup>  
P<sub>n</sub> Pressure on hub                                      N/mm<sup>2</sup>

**IMPORTANT:** The screw tightening torque M<sub>s</sub> can be reduced by 40% of the value indicated in the table. M<sub>t</sub>, F<sub>ax</sub>, P<sub>w</sub>, P<sub>n</sub> decrease proportionally.

For further information or in case of needs of diameters or dimensions different to those in the table, please contact our Technical Department.

Internal - self-centering

## SIT-LOCK® 5A internal locking device - self-centering

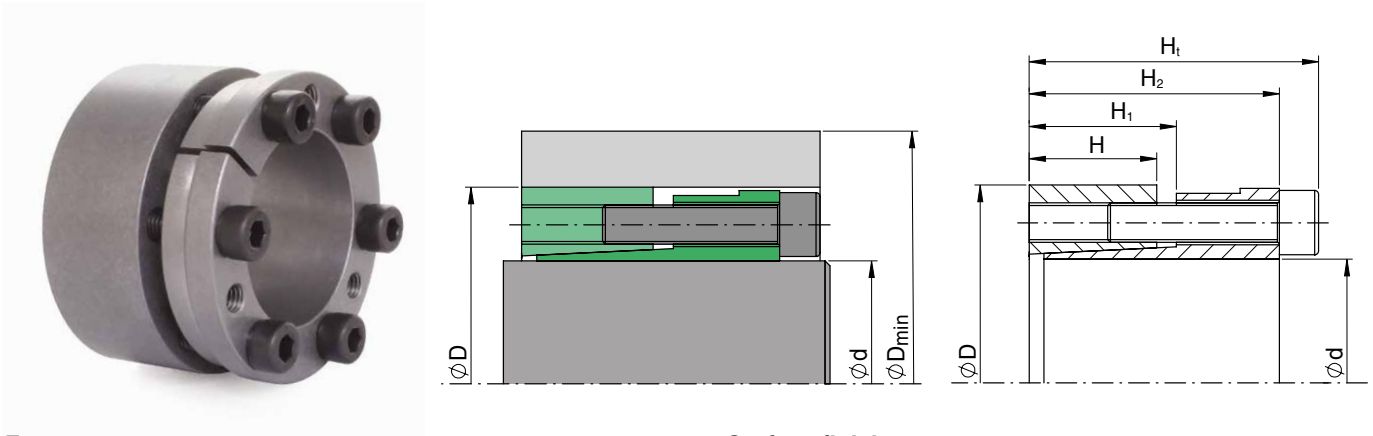

### Features

Composed of an inner ring and outer ring both with splits. This type of locking device is particularly suitable for applications that require excellent hub-to-shaft concentricity and perpendicularity. The table shows performance data for the following tolerances:

shaft d h8 - coupling seat on hub H8

***Do not use molybdenum disulphide-based oils or greases that reduce the coefficient of friction  $\mu$ . The values in the table are calculated with  $\mu$  0.12.***

### Hub to shaft centering

The SIT-LOCK® 5A locking device is self-centering so it does not require a centering base between the shaft and hub. This allows for hubs with reduced widths which saves on materials and leads to reduced costs.

### Installation with non-lubricated surfaces (dry)

The SIT-LOCK® 5A locking device is lubricated with oil before delivery to protect it from oxidation during storage. The values shown in the table have been calculated for applications with oiled contact surfaces. For dry installation, the values are:

$M_t, F_{ax} +8\%$

$P_w, P_n -13\%$

To get these values, the locking device must be completely disassembled and all its component surfaces must be cleaned with solvent. The shaft and hub contact surfaces must also be completely clean and oil-free.

### Axial displacement

When tightening the screws there is a hub to shaft axial displacement. The extent of axial displacement depends on the tolerances.

### Radial loads

SIT-LOCK® 5A is suitable for use with applications subject to high radial loads. For further information, please contact our Technical Department.

### Surface finish

Normal surface finish is sufficient. The following values are recommended:

$R_a \leq 3,2 \mu m - R_t \leq 16 \mu m$

### Installation

The locking device is supplied ready to assemble. Clean the shaft contact surfaces thoroughly and apply oil. Mount the shaft, hub and locking device in the desired position.

Screw tightening sequence:

- tighten two diametrically opposed screws until the locking device surfaces make contact with the shaft and hub;
- tighten all screws to 50% of the screw tightening torque value  $M_s$  indicated in the table in a 'criss-cross' sequence;
- repeat to 100% of the  $M_s$  tightening torque indicated in the table;
- in continuous sequence, check that the tightening torque  $M_s$  has been achieved.

### Removal

Gradually loosen the clamping screws. Remove the clamping screws and insert them into the special removal threads on the inner ring flange.

Tighten the screws in a 'criss-cross' sequence until the locking device is released.

### Reusing the locking device

When reusing the locking device, check all the surfaces are clean and show no obvious signs of deformation or seizing. Clean and oil all surfaces and threads. Check the screws have not been deformed. Oil the screws and assemble the locking device as originally supplied.

## SIT-LOCK® 5A internal locking device - self-centering

Dimensions [mm]					Clamping screws DIN 912 12.9			Values with tolerances for shaft h8/hub H8				
d x D	H	H <sub>1</sub>	H <sub>2</sub>	H <sub>t</sub>	Type	N°	M <sub>s</sub> [Nm]	M <sub>t</sub> [Nm]	F <sub>ax</sub> [kN]	P <sub>w</sub> [N/mm <sup>2</sup> ]	P <sub>n</sub> [N/mm <sup>2</sup> ]	
18 x 47	26	29	42	48	M6	6	17	492	55	310	120	
19 x 47	26	29	42	48	M6	6	17	520	55	294	120	
20 x 47	26	29	42	48	M6	6	17	547	55	279	120	
22 x 47	26	29	42	48	M6	6	17	602	55	254	120	
24 x 50	26	29	42	48	M6	6	17	656	55	233	110	
25 x 50	26	29	42	48	M6	6	17	684	55	223	110	
28 x 55	26	29	42	48	M6	6	17	766	55	199	100	
30 x 55	26	29	42	48	M6	6	17	821	55	186	100	
32 x 60	26	29	42	48	M6	9	17	1.314	82	262	140	
35 x 60	26	29	42	48	M6	9	17	1.437	82	239	140	
38 x 65	26	29	42	48	M6	9	17	1.560	82	220	130	
40 x 65	26	29	42	48	M6	9	17	1.642	82	209	130	
42 x 75	30	34	51	59	M8	6	41	2.123	101	213	120	
45 x 75	30	34	51	59	M8	6	41	2.275	101	199	120	
48 x 80	30	34	51	59	M8	6	41	2.426	101	186	110	
50 x 80	30	34	51	59	M8	6	41	2.528	101	179	110	
55 x 85	30	34	51	59	M8	9	41	4.169	152	244	160	
60 x 90	30	34	51	59	M8	9	41	4.548	152	223	150	
65 x 95	30	34	51	59	M8	9	41	4.927	152	206	140	
70 x 110	40	45	56	66	M10	7	83	6.556	187	177	115	
75 x 115	40	45	56	66	M10	7	83	7.024	187	166	110	
80 x 120	40	45	56	66	M10	7	83	7.492	187	155	105	
85 x 125	40	45	56	66	M10	8	83	9.095	214	167	115	
90 x 130	40	45	56	66	M10	8	83	9.630	214	158	110	
95 x 135	40	45	56	66	M10	10	83	12.706	268	187	130	
100 x 145	45	52	65	77	M12	7	145	13.635	273	161	110	
110 x 155	45	52	65	77	M12	8	145	17.138	312	167	120	
120 x 165	45	52	65	77	M12	10	145	23.370	390	191	140	
130 x 180	45	52	65	77	M12	12	145	30.381	467	212	155	
140 x 190	50	59	74	88	M14	10	230	37.415	535	203	150	
150 x 200	50	59	74	88	M14	12	230	48.105	641	227	170	
160 x 210	50	59	74	88	M14	12	230	51.312	641	213	160	
170 x 225	50	59	74	88	M14	14	230	63.606	748	234	175	
180 x 235	50	59	74	88	M14	14	230	67.347	748	221	170	
190 x 250	50	59	74	88	M14	15	230	76.162	802	224	170	
200 x 260	50	59	74	88	M14	15	230	80.170	802	213	165	
220 x 285	64	72	94	110	M16	12	355	98.054	891	168	130	
240 x 305	64	72	94	110	M16	15	355	133.704	1.114	192	150	

M<sub>s</sub> Screw tightening torque Nm  
M<sub>t</sub> Transmissible torque Nm  
F<sub>ax</sub> Transmissible axial force kN  
P<sub>w</sub> Pressure on shaft N/mm<sup>2</sup>  
P<sub>n</sub> Pressure on hub N/mm<sup>2</sup>

**IMPORTANT:** The screw tightening torque M<sub>s</sub> can be reduced by 40% of the value indicated in the table. M<sub>t</sub>, F<sub>ax</sub>, P<sub>w</sub>, P<sub>n</sub> decrease proportionally.

For further information or in case of needs of diameters or dimensions different to those in the table, please contact our Technical Department.

## SIT-LOCK® 5B internal locking device - self-centering

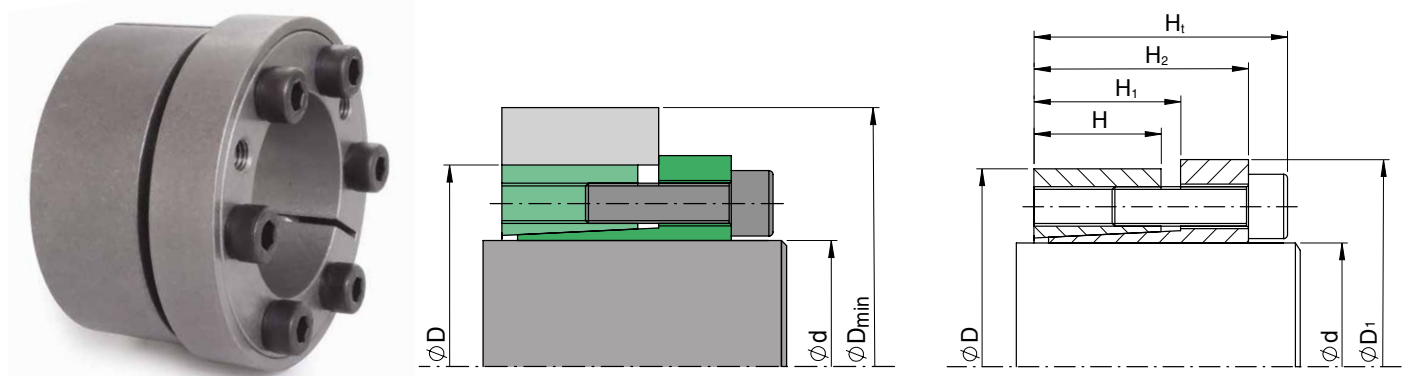

### Features

Composed of an inner ring and outer ring both with splits. This type of locking device is particularly suitable for applications that require excellent hub-to-shaft concentricity and perpendicularity. It is also used for locking hubs with lower mechanical properties. The table shows performance data for the following tolerances:

shaft d h8 - coupling seat on hub H8

**Do not use molybdenum disulphide-based oils or greases that reduce the coefficient of friction  $\mu$ . The values in the table are calculated with  $\mu$  0.12.**

### Hub to shaft centering

The SIT-LOCK® 5B locking device is self-centering so it does not require a centering base between the shaft and hub. This allows for hubs with reduced widths which saves on materials and leads to reduced costs.

### Installation with non-lubricated surfaces (dry)

The SIT-LOCK® 5B locking device is lubricated with oil before delivery to protect it from oxidation during storage. The values shown in the table have been calculated for applications with oiled contact surfaces. For dry installation, the values are:

$M_t, F_{ax} +5\%$

$P_w, P_n -16\%$

To get these values, the locking device must be completely disassembled and all its component surfaces must be cleaned with solvent. The shaft and hub contact surfaces must also be completely clean and oil-free.

### Axial displacement

When tightening the screws there is no hub to shaft axial displacement.

### Radial loads

SIT-LOCK® 5B is suitable for use with applications subject to high radial loads. For further information, please contact our Technical Department.

### Surface finish

Normal surface finish is sufficient. The following values are recommended:

$R_a \leq 3,2 \mu\text{m} - R_t \leq 16 \mu\text{m}$

### Installation

The locking device is supplied ready to assemble. Clean the shaft contact surfaces thoroughly and apply oil. Mount the shaft, hub and locking device in the desired position.

Screw tightening sequence:

- tighten two diametrically opposed screws until the locking device surfaces make contact with the shaft and hub;
- tighten all screws to 50% of the screw tightening torque value  $M_s$  indicated in the table in a 'criss-cross' sequence;
- repeat to 100% of the  $M_s$  tightening torque indicated in the table;
- in continuous sequence, check that the tightening torque  $M_s$  has been achieved.

### Removal

Gradually loosen the clamping screws. Remove the clamping screws and insert them into the special removal threads on the inner ring flange.

Tighten the screws in a 'criss-cross' sequence until the locking device is released.

### Reusing the locking device

When reusing the locking device, check all the surfaces are clean and show no obvious signs of deformation or seizing. Clean and oil all surfaces and threads. Check the screws have not been deformed. Oil the screws and assemble the locking device as originally supplied.

### SIT-LOCK® 5B stop ring

The stop ring, which prevents the hub from moving, is also available in different widths or integrated with the inner ring flange. The locking device is guaranteed to function in either case.

## SIT-LOCK® 5B internal locking device - self-centering

Dimensions [mm]						Clamping screws DIN 912 12.9			Values with tolerances for shaft h8/hub H8			
d x D	H	H <sub>1</sub>	H <sub>2</sub>	H <sub>t</sub>	D <sub>1</sub>	Type	N°	M <sub>s</sub> [Nm]	M <sub>t</sub> [Nm]	F <sub>ax</sub> [kN]	P <sub>w</sub> [N/mm <sup>2</sup> ]	P <sub>n</sub> [N/mm <sup>2</sup> ]
18 x 47	26	29	42	48	53	M6	6	17	307	34	193	75
19 x 47	26	29	42	48	53	M6	6	17	324	34	183	75
20 x 47	26	29	42	48	53	M6	6	17	341	34	174	75
22 x 47	26	29	42	48	53	M6	6	17	375	34	158	75
24 x 50	26	29	42	48	56	M6	6	17	409	34	145	70
25 x 50	26	29	42	48	56	M6	6	17	426	34	139	70
28 x 55	26	29	42	48	61	M6	6	17	477	34	124	65
30 x 55	26	29	42	48	61	M6	6	17	512	34	116	65
32 x 60	26	29	42	48	66	M6	9	17	819	51	163	85
35 x 60	26	29	42	48	66	M6	9	17	896	51	149	85
38 x 65	26	29	42	48	71	M6	9	17	973	51	137	80
40 x 65	26	29	42	48	71	M6	9	17	1.024	51	131	80
42 x 75	30	34	51	59	81	M8	6	41	1.323	63	133	75
45 x 75	30	34	51	59	81	M8	6	41	1.418	63	124	75
48 x 80	30	34	51	59	86	M8	6	41	1.512	63	116	70
50 x 80	30	34	51	59	86	M8	6	41	1.575	63	111	70
55 x 85	30	34	51	59	91	M8	9	41	2.599	95	152	100
60 x 90	30	34	51	59	96	M8	9	41	2.835	95	139	95
65 x 95	30	34	51	59	102	M8	9	41	3.071	95	129	90
70 x 110	40	45	56	66	117	M10	7	83	4.088	117	111	70
75 x 115	40	45	56	66	122	M10	7	83	4.380	117	103	65
80 x 120	40	45	56	66	127	M10	7	83	4.672	117	97	65
85 x 125	40	45	56	66	132	M10	8	83	5.670	133	104	70
90 x 130	40	45	56	66	137	M10	8	83	6.003	133	98	70
95 x 135	40	45	56	66	142	M10	10	83	7.923	167	116	80
100 x 145	46	52	65	77	153	M12	7	145	8.500	170	98	70
110 x 155	46	52	65	77	163	M12	8	145	10.687	194	102	70
120 x 165	46	52	65	77	173	M12	10	145	14.574	243	117	85
130 x 180	46	52	65	77	188	M12	12	145	18.941	291	129	95
140 x 190	51	59	74	88	199	M14	10	230	23.324	333	124	90
150 x 200	51	59	74	88	209	M14	12	230	29.993	400	139	105
160 x 210	51	59	74	88	219	M14	12	230	31.992	400	130	100
170 x 225	51	59	74	88	234	M14	14	230	39.653	467	143	110
180 x 235	51	59	74	88	244	M14	14	230	41.985	467	135	105
190 x 250	51	59	74	88	259	M14	15	230	47.481	500	137	105
200 x 260	51	59	74	88	269	M14	15	230	49.980	500	130	100
220 x 285	64	72	94	110	294	M16	12	355	61.138	556	105	80
240 x 305	64	72	94	110	314	M16	15	355	83.364	695	120	95

M<sub>s</sub> Screw tightening torque      Nm  
M<sub>t</sub> Transmissible torque      Nm  
F<sub>ax</sub> Transmissible axial force      kN  
P<sub>w</sub> Pressure on shaft      N/mm<sup>2</sup>  
P<sub>n</sub> Pressure on hub      N/mm<sup>2</sup>

**IMPORTANT:** The screw tightening torque M<sub>s</sub> can be reduced by 40% of the value indicated in the table. M<sub>t</sub>, F<sub>ax</sub>, P<sub>w</sub>, P<sub>n</sub> decrease proportionally.

For further information or in case of needs of diameters or dimensions different to those in the table, please contact our Technical Department.

Internal - self-centering

## SIT-LOCK® 6 internal locking device - self-centering

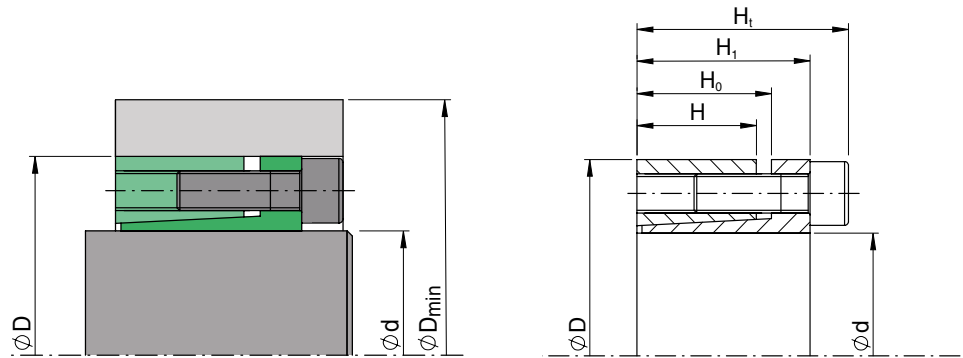

### Features

Composed of an inner ring and outer ring both with splits. This type of locking device is particularly suitable for applications that require good hub-to-shaft concentricity and perpendicularity. The table shows performance data for the following tolerances:

shaft d h8 - coupling seat on hub H8

***Do not use molybdenum disulphide-based oils or greases that reduce the coefficient of friction  $\mu$ . The values in the table are calculated with  $\mu$  0.12.***

### Hub to shaft centering

The SIT-LOCK® 6 locking device is self-centering so it does not require a centering base between the shaft and hub. This allows for hubs with reduced widths which saves on materials and leads to reduced costs.

### Installation with non-lubricated surfaces (dry)

The SIT-LOCK® 6 locking device is lubricated with oil before delivery to protect it from oxidation during storage. The values shown in the table have been calculated for applications with oiled contact surfaces. For dry installation, the values are:

$M_t, F_{ax} +8\%$

$P_w, P_n -13\%$

To get these values, the locking device must be completely disassembled and all its component surfaces must be cleaned with solvent. The shaft and hub contact surfaces must also be completely clean and oil-free.

### Axial displacement

When tightening the screws there is a hub to shaft axial displacement. The extent of axial displacement depends on the tolerances.

### Radial loads

The SIT-LOCK® 6 locking device is suitable for applications subject to high radial loads. For further information, please contact our Technical Department.

### Surface finish

Normal surface finish is sufficient. The following values are recommended:

$R_a \leq 3,2 \mu m - R_t \leq 16 \mu m$

### Installation

The locking device is supplied ready to assemble. Clean the shaft contact surfaces thoroughly and apply oil. Mount the shaft, hub and locking device in the desired position.

Screw tightening sequence:

- tighten two diametrically opposed screws until the locking device surfaces make contact with the shaft and hub;
- tighten all screws to 50% of the screw tightening torque value  $M_s$  indicated in the table in a 'criss-cross' sequence;
- repeat to 100% of the  $M_s$  tightening torque indicated in the table;
- in continuous sequence, check that the tightening torque  $M_s$  has been achieved.

### Removal

Gradually loosen the clamping screws. Remove the clamping screws and insert them into the special removal threads on the inner ring flange.

Tighten the screws in a 'criss-cross' sequence until the locking device is released.

### Reusing the locking device

When reusing the locking device, check all the surfaces are clean and show no obvious signs of deformation or seizing. Clean and oil all surfaces and threads. Check the screws have not been deformed. Oil the screws and assemble the locking device as originally supplied.

## SIT-LOCK® 6 internal locking device - self-centering

Dimensions [mm]					Clamping screws DIN 912 12.9			Values with tolerances for shaft h8/hub H8			
d x D	H	H <sub>0</sub>	H <sub>1</sub>	H <sub>t</sub>	Type	N°	M <sub>s</sub> [Nm]	M <sub>t</sub> [Nm]	F <sub>ax</sub> [kN]	P <sub>w</sub> [N/mm <sup>2</sup> ]	P <sub>n</sub> [N/mm <sup>2</sup> ]
18 x 47	17	22	28	34	M6	5	14	342	38	330	125
19 x 47	17	22	28	34	M6	5	14	361	38	312	125
20 x 47	17	22	28	34	M6	5	14	380	38	297	125
22 x 47	17	22	28	34	M6	5	14	418	38	270	125
24 x 50	17	22	28	34	M6	5	14	456	38	247	120
25 x 50	17	22	28	34	M6	6	14	571	46	285	140
28 x 55	17	22	28	34	M6	6	14	640	46	254	130
30 x 55	17	22	28	34	M6	6	14	686	46	237	130
32 x 60	17	22	28	34	M6	8	14	974	61	297	160
35 x 60	17	22	28	34	M6	8	14	1.066	61	271	160
38 x 65	17	22	28	34	M6	8	14	1.157	61	250	145
40 x 65	17	22	28	34	M6	8	14	1.218	61	237	145
42 x 75	20	25	33	41	M8	7	35	2.060	98	310	175
45 x 75	20	25	33	41	M8	7	35	2.207	98	289	175
48 x 80	20	25	33	41	M8	7	35	2.354	98	271	165
50 x 80	20	25	33	41	M8	7	35	2.453	98	260	165
55 x 85	20	25	33	41	M8	8	35	3.083	112	270	175
60 x 90	20	25	33	41	M8	8	35	3.363	112	248	165
65 x 95	20	25	33	41	M8	9	35	4.098	126	257	175
70 x 110	24	30	40	50	M10	8	70	6.332	181	286	180
75 x 115	24	30	40	50	M10	8	70	6.784	181	267	175
80 x 120	24	30	40	50	M10	8	70	7.236	181	250	165
85 x 125	24	30	40	50	M10	9	70	8.649	204	265	180
90 x 130	24	30	40	50	M10	9	70	9.158	204	250	175
95 x 135	24	30	40	50	M10	10	70	10.740	226	263	185
100 x 145	26	32	44	56	M12	8	125	13.590	272	277	190
110 x 155	26	32	44	56	M12	8	125	14.949	272	252	180
120 x 165	26	32	44	56	M12	9	125	18.342	306	260	190
130 x 180	34	40	54	64	M12	12	125	26.494	408	245	175
140 x 190	34	40	54	68	M14	9	190	28.154	402	224	165
150 x 200	34	40	54	68	M14	10	190	33.518	447	232	175
160 x 210	34	40	54	68	M14	11	190	39.328	492	240	185
170 x 225	44	50	64	78	M14	12	190	45.586	536	190	145
180 x 235	44	50	64	78	M14	12	190	48.267	536	180	140
190 x 250	44	50	64	78	M14	15	190	63.688	670	213	160
200 x 260	44	50	64	78	M14	15	190	67.040	670	202	155

M<sub>s</sub> Screw tightening torque Nm  
M<sub>t</sub> Transmissible torque Nm  
F<sub>ax</sub> Transmissible axial force kN  
P<sub>w</sub> Pressure on shaft N/mm<sup>2</sup>  
P<sub>n</sub> Pressure on hub N/mm<sup>2</sup>

**IMPORTANT:** The screw tightening torque M<sub>s</sub> can be reduced by 30% of the value indicated in the table. M<sub>t</sub>, F<sub>ax</sub>, P<sub>w</sub>, P<sub>n</sub> decrease proportionally.

For further information or in case of needs of diameters or dimensions different to those in the table, please contact our Technical Department.

Internal - self-centering

## SIT-LOCK® 7 internal locking device - self-centering

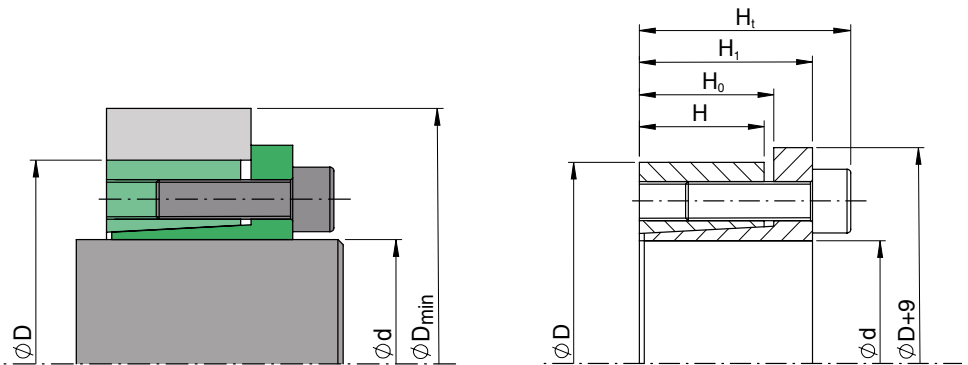

### Features

Composed of an inner ring and outer ring both with splits. This type of locking device is particularly suitable for applications that require excellent hub-to-shaft concentricity and perpendicularity. It is also used for locking hubs with limited widths. The table shows performance data for the following tolerances:

shaft d h8 - coupling seat on hub H8

**Do not use molybdenum disulphide-based oils or greases that reduce the coefficient of friction  $\mu$ . The values in the table are calculated with  $\mu$  0.12.**

### Hub to shaft centering

The SIT-LOCK® 7 locking device is self-centering so it does not require a centering base between the shaft and hub. This allows for hubs with reduced widths which saves on materials and leads to reduced costs.

### Installation with non-lubricated surfaces (dry)

The SIT-LOCK® 7 locking device is lubricated with oil before delivery to protect it from oxidation during storage. The values shown in the table have been calculated for applications with oiled contact surfaces. For dry installation, the values are:

$M_t, F_{ax} +5\%$

$P_w, P_n -16\%$

To get these values, the locking device must be completely disassembled and all its component surfaces must be cleaned with solvent. The shaft and hub contact surfaces must also be completely clean and oil-free.

### Axial displacement

When tightening the screws there is no hub to shaft axial displacement.

### Radial loads

SIT-LOCK® 7 is suitable for use with applications subject to high radial loads. For further information, please contact our Technical Department.

### Surface finish

Normal surface finish is sufficient. The following values are recommended:

$R_a \leq 3,2 \mu m - R_t \leq 16 \mu m$

### Installation

The locking device is supplied ready to assemble. Clean the shaft contact surfaces thoroughly and apply oil. Mount the shaft, hub and locking device in the desired position.

Screw tightening sequence:

- tighten two diametrically opposed screws until the locking device surfaces make contact with the shaft and hub;
- tighten all screws to 50% of the screw tightening torque value  $M_s$  indicated in the table in a 'criss-cross' sequence;
- repeat to 100% of the  $M_s$  tightening torque indicated in the table;
- in continuous sequence, check that the tightening torque  $M_s$  has been achieved.

### Removal

Gradually loosen the clamping screws. Remove the clamping screws and insert them into the special removal threads on the inner ring flange.

Tighten the screws in a 'criss-cross' sequence until the locking device is released.

### Reusing the locking device

When reusing the locking device, check all the surfaces are clean and show no obvious signs of deformation or seizing. Clean and oil all surfaces and threads. Check the screws have not been deformed. Oil the screws and assemble the locking device as originally supplied.

## SIT-LOCK® 7 internal locking device - self-centering

Dimensions [mm]					Clamping screws DIN 912 12.9			Values with tolerances for shaft h8/hub H8				
d x D	H	H <sub>0</sub>	H <sub>1</sub>	H <sub>t</sub>	Type	N°	M <sub>s</sub> [Nm]	M <sub>t</sub> [Nm]	F <sub>ax</sub> [kN]	P <sub>w</sub> [N/mm <sup>2</sup> ]	P <sub>n</sub> [N/mm <sup>2</sup> ]	
18 x 47	17	22	28	34	M6	5	17	256	28	246	95	
19 x 47	17	22	28	34	M6	5	17	270	28	233	95	
20 x 47	17	22	28	34	M6	5	17	284	28	222	95	
22 x 47	17	22	28	34	M6	5	17	312	28	202	95	
24 x 50	17	22	28	34	M6	5	17	341	28	185	90	
25 x 50	17	22	28	34	M6	6	17	426	34	213	105	
28 x 55	17	22	28	34	M6	6	17	477	34	190	95	
30 x 55	17	22	28	34	M6	6	17	512	34	177	95	
32 x 60	17	22	28	34	M6	8	17	728	46	222	120	
35 x 60	17	22	28	34	M6	8	17	796	46	203	120	
38 x 65	17	22	28	34	M6	8	17	865	46	187	110	
40 x 65	17	22	28	34	M6	8	17	910	46	177	110	
42 x 75	20	25	33	41	M8	7	41	1.544	74	232	130	
45 x 75	20	25	33	41	M8	7	41	1.654	74	217	130	
48 x 80	20	25	33	41	M8	7	41	1.764	74	203	120	
50 x 80	20	25	33	41	M8	7	41	1.838	74	195	120	
55 x 85	20	25	33	41	M8	8	41	2.310	84	203	130	
60 x 90	20	25	33	41	M8	8	41	2.520	84	186	125	
65 x 95	20	25	33	41	M8	9	41	3.071	95	193	130	
70 x 110	24	30	40	50	M10	8	83	4.669	133	211	135	
75 x 115	24	30	40	50	M10	8	83	5.003	133	197	130	
80 x 120	24	30	40	50	M10	8	83	5.336	133	184	125	
85 x 125	24	30	40	50	M10	9	83	6.379	150	195	135	
90 x 130	24	30	40	50	M10	9	83	6.755	150	184	130	
95 x 135	24	30	40	50	M10	10	83	7.923	167	194	135	
100 x 145	26	32	44	56	M12	8	145	9.715	194	198	135	
110 x 155	26	32	44	56	M12	8	145	10.687	194	180	130	
120 x 165	26	32	44	56	M12	9	145	13.116	219	186	135	
130 x 180	34	40	54	64	M12	12	145	18.941	291	175	125	
140 x 190	34	40	54	68	M14	9	230	20.993	300	167	125	
150 x 200	34	40	54	68	M14	10	230	24.990	333	173	130	
160 x 210	34	40	54	68	M14	11	230	29.328	367	179	135	
170 x 225	44	50	64	78	M14	12	230	33.992	400	142	105	
180 x 235	44	50	64	78	M14	12	230	35.991	400	134	105	
190 x 250	44	50	64	78	M14	15	230	47.481	500	159	120	
200 x 260	44	50	64	78	M14	15	230	49.980	500	151	115	
220 x 285	50	56	75	91	M16	12	355	61.138	556	134	105	
240 x 305	50	56	75	91	M16	15	355	83.364	695	154	120	
260 x 325	50	56	75	91	M16	16	355	96.330	741	151	120	
280 x 355	60	66	87	105	M18	16	485	124.824	892	141	110	
300 x 375	60	66	87	105	M18	18	485	150.465	1.003	148	120	
320 x 405	74	81	101	121	M20	18	690	208.208	1.301	146	115	
340 x 425	74	81	101	121	M20	21	690	258.094	1.518	160	130	
360 x 455	86	94	116	138	M22	18	930	291.564	1.620	139	110	
380 x 475	86	94	116	138	M22	21	930	359.062	1.890	153	125	
400 x 495	86	94	116	138	M22	21	930	377.960	1.890	146	120	
420 x 515	86	94	116	138	M22	21	930	396.858	1.890	139	115	
440 x 535	86	94	116	138	M22	21	930	415.756	1.890	132	110	
460 x 555	86	94	116	138	M22	22	930	455.354	1.980	133	110	
480 x 575	86	94	116	138	M22	24	930	518.352	2.160	139	115	
500 x 595	86	94	116	138	M22	24	930	539.950	2.160	133	110	

M<sub>s</sub> Screw tightening torque Nm  
M<sub>t</sub> Transmissible torque Nm  
F<sub>ax</sub> Transmissible axial force kN  
P<sub>w</sub> Pressure on shaft N/mm<sup>2</sup>  
P<sub>n</sub> Pressure on hub N/mm<sup>2</sup>

**IMPORTANT:** The screw tightening torque M<sub>s</sub> can be reduced by 40% of the value indicated in the table. M<sub>t</sub>, F<sub>ax</sub>, P<sub>w</sub>, P<sub>n</sub> decrease proportionally. For further information or in case of needs of diameters or dimensions different to those in the table, please contact our Technical Department.

Internal - self-centering

## SIT-LOCK® 8 internal locking device - self-centering

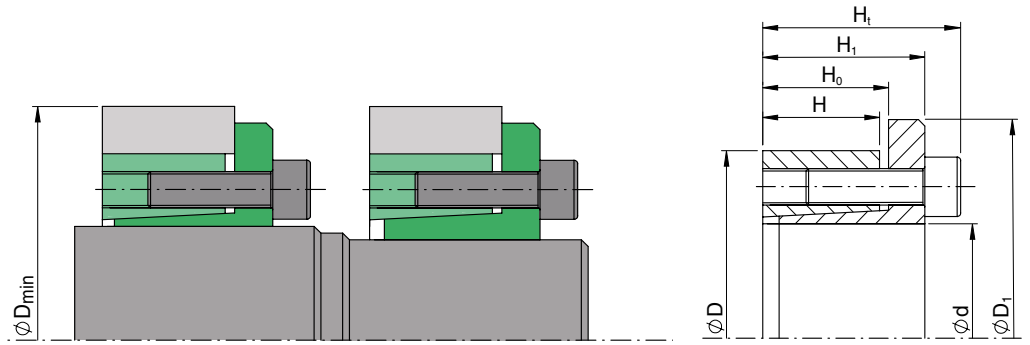

### Features

Composed of an inner ring and outer ring both with splits. This type of locking device is particularly suitable for applications that require excellent hub-to-shaft concentricity and perpendicularity. **Allows the same hub, with the same external diameter, to be used on shafts of different diameters.**

Example:

shaft diameter 30 mm: SIT-LOCK® 8 30 x 55  
shaft diameter 20 mm: SIT-LOCK® 8 20 x 55

The table shows performance data for the following tolerances:

shaft d h8 - coupling seat on hub H8

**Designed for applications that require quick installation,** resulting in lower costs. It has the following advantages over SIT-LOCK® 1:

#### SIT-LOCK® 8 40 x 65

Transmissible torque: **1051 Nm**  
Number of screws: **5 M8**  
SELF-Centering

#### SIT-LOCK® 1 40 x 65

Transmissible torque: **1145 Nm**  
Number of screws: **14 M6**  
NOT SELF-Centering

**Notes:** using SIT-LOCK® 8 rather than SIT-LOCK® 1 allows for a 65% reduction in installation time and considerably lower application costs.

### High torque transmission

With the same shaft size, e.g. 30 mm, it allows for higher torque transmission at a very low cost, for example:

SIT-LOCK® 8 30 x 55 = 473 Nm  
SIT-LOCK® 8 30 x 65 = 789 Nm  
SIT-LOCK® 8 30 x 80 = 1103 Nm

**Do not use molybdenum disulphide-based oils or greases that reduce the coefficient of friction  $\mu$ . The values in the table are calculated with  $\mu$  0.12.**

### Hub to shaft centering

The SIT-LOCK® 8 locking device is self-centering so it does not require a centering base between the shaft and hub.

### Installation with non-lubricated surfaces (dry)

See SIT-LOCK® 7 specifications as they are the same.

### Axial displacement

When tightening the screws there is no hub to shaft axial displacement.

### Surface finish

Normal surface finish is sufficient. The following values are recommended:

$R_a \leq 3,2 \mu\text{m}$  -  $R_t \leq 16 \mu\text{m}$

### Installation

The locking device is supplied ready to assemble. Clean the shaft contact surfaces thoroughly and apply oil. Mount the shaft, hub and locking device in the desired position.

Screw tightening sequence:

- tighten two diametrically opposed screws until the locking device surfaces make contact with the shaft and hub;
- tighten all screws to 50% of the screw tightening torque value  $M_s$  indicated in the table in a 'criss-cross' sequence;
- repeat to 100% of the  $M_s$  tightening torque indicated in the table;
- in continuous sequence, check that the tightening torque  $M_s$  has been achieved.

### Removal

Gradually loosen the clamping screws. Remove the clamping screws and insert them into the special removal threads on the inner ring flange. Tighten the screws in a 'criss-cross' sequence until the locking device is released.

### Reusing the locking device

When reusing the locking device, check all the surfaces are clean and show no obvious signs of deformation or seizing. Clean and oil all surfaces and threads. Check the screws have not been deformed. Oil the screws and assemble the locking device as originally supplied.

## SIT-LOCK® 8 internal locking device - self-centering

Dimensions [mm]						Clamping screws DIN 912 12.9			Values with tolerances for shaft h8/hub H8			
d x D	H	H <sub>0</sub>	H <sub>1</sub>	H <sub>t</sub>	D <sub>1</sub>	Type	N°	M <sub>s</sub> [Nm]	M <sub>t</sub> [Nm]	F <sub>ax</sub> [kN]	P <sub>w</sub> [N/mm <sup>2</sup> ]	P <sub>n</sub> [N/mm <sup>2</sup> ]
14 x 55	17	22	30	38	62	M8	3	41	221	32	351	90
16 x 55	17	22	30	38	62	M8	3	41	252	32	307	90
18 x 55	17	22	30	38	62	M8	3	41	284	32	273	90
19 x 55	17	22	30	38	62	M8	3	41	299	32	259	90
20 x 55	17	22	30	38	62	M8	3	41	315	32	246	90
22 x 55	17	22	30	38	62	M8	3	41	347	32	224	90
24 x 55	17	22	30	38	62	M8	3	41	378	32	205	90
25 x 55	17	22	30	38	62	M8	3	41	394	32	197	90
28 x 55	17	22	30	38	62	M8	3	41	441	32	176	90
30 x 55	17	22	30	38	62	M8	3	41	473	32	164	90
24 x 65	17	22	30	38	72	M8	5	41	630	53	341	125
25 x 65	17	22	30	38	72	M8	5	41	657	53	328	125
28 x 65	17	22	30	38	72	M8	5	41	735	53	293	125
30 x 65	17	22	30	38	72	M8	5	41	788	53	273	125
32 x 65	17	22	30	38	72	M8	5	41	840	53	256	125
33 x 65	17	22	30	38	72	M8	5	41	866	53	248	125
35 x 65	17	22	30	38	72	M8	5	41	919	53	234	125
38 x 65	17	22	30	38	72	M8	5	41	998	53	216	125
40 x 65	17	22	30	38	72	M8	5	41	1.051	53	205	125
30 x 80	20	25	33	41	87	M8	7	41	1.103	74	325	120
32 x 80	20	25	33	41	87	M8	7	41	1.177	74	305	120
33 x 80	20	25	33	41	87	M8	7	41	1.213	74	296	120
35 x 80	20	25	33	41	87	M8	7	41	1.287	74	279	120
38 x 80	20	25	33	41	87	M8	7	41	1.397	74	257	120
40 x 80	20	25	33	41	87	M8	7	41	1.471	74	244	120
42 x 80	20	25	33	41	87	M8	7	41	1.544	74	232	120
45 x 80	20	25	33	41	87	M8	7	41	1.655	74	217	120
48 x 80	20	25	33	41	87	M8	7	41	1.765	74	203	120
50 x 80	20	25	33	41	87	M8	7	41	1.838	74	195	120

M<sub>s</sub> Screw tightening torque                      Nm  
M<sub>t</sub> Transmissible torque                              Nm  
F<sub>ax</sub> Transmissible axial force                      kN  
P<sub>w</sub> Pressure on shaft                                  N/mm<sup>2</sup>  
P<sub>n</sub> Pressure on hub                                      N/mm<sup>2</sup>

**IMPORTANT:** The screw tightening torque M<sub>s</sub> can be reduced by 40% of the value indicated in the table. M<sub>t</sub>, F<sub>ax</sub>, P<sub>w</sub>, P<sub>n</sub> decrease proportionally.

For further information or in case of needs of diameters or dimensions different to those in the table, please contact our Technical Department.

Internal - self-centering

## SIT-LOCK® 12 internal locking device - self-centering

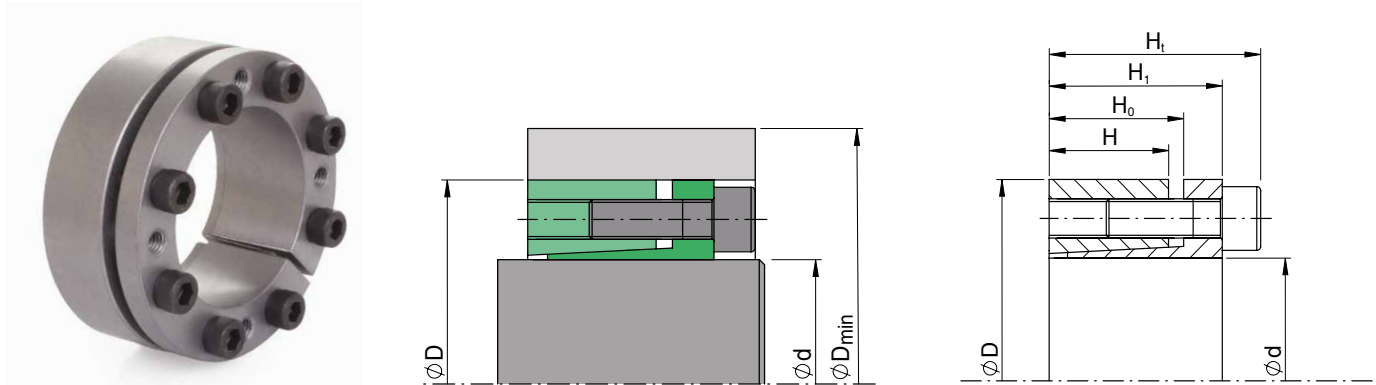

### Features

Composed of an inner ring and outer ring both with splits. This type of locking device is particularly suitable for applications that require good hub-to-shaft concentricity and perpendicularity. The table shows performance data for the following tolerances:

shaft d h8 - coupling seat on hub H8

***Do not use molybdenum disulphide-based oils or greases that reduce the coefficient of friction  $\mu$ . The values in the table are calculated with  $\mu$  0.12.***

### Hub to shaft centering

The SIT-LOCK® 12 locking device is self-centering so it does not require a centering base between the shaft and hub. This allows for hubs with reduced widths which saves on materials and leads to reduced costs.

### Installation with non-lubricated surfaces (dry)

The SIT-LOCK® 12 locking device is lubricated with oil before delivery to protect it from oxidation during storage. The values shown in the table have been calculated for applications with oiled contact surfaces. For dry installation, the values are:

$$M_t, F_{ax} +8\%$$

$$P_w, P_n -13\%$$

To get these values, the locking device must be completely disassembled and all its component surfaces must be cleaned with solvent. The shaft and hub contact surfaces must also be completely clean and oil-free.

### Axial displacement

When tightening the screws there is a hub to shaft axial displacement. The extent of axial displacement depends on the tolerances.

### Radial loads

The SIT-LOCK® 12 locking device is suitable for applications subject to high radial loads. For further information, please contact our Technical Department.

### Surface finish

Normal surface finish is sufficient. The following values are recommended:

$$R_a \leq 3,2 \mu\text{m} - R_t \leq 16 \mu\text{m}$$

### Installation

The locking device is supplied ready to assemble. Clean the shaft contact surfaces thoroughly and apply oil. Mount the shaft, hub and locking device in the desired position.

Screw tightening sequence:

- tighten two diametrically opposed screws until the locking device surfaces make contact with the shaft and hub;
- tighten all screws to 50% of the screw tightening torque value  $M_s$  indicated in the table in a 'criss-cross' sequence;
- repeat to 100% of the  $M_s$  tightening torque indicated in the table;
- in continuous sequence, check that the tightening torque  $M_s$  has been achieved.

### Removal

Gradually loosen the clamping screws. Remove the clamping screws and insert them into the special removal threads on the inner ring flange.

Tighten the screws in a 'criss-cross' sequence until the locking device is released.

### Reusing the locking device

When the locking device is being reuse, make sure that all the surfaces are clean and show no obvious signs of deformation or seizing. Clean and oil all surfaces and threads. Check the screws have not been deformed. Oil the screws and assemble the locking device as originally supplied.

## SIT-LOCK® 12 internal locking device - self-centering

Dimensions [mm]					Clamping screws DIN 912 12.9			Values with tolerances for shaft h8/hub H8				
d x D	H	H <sub>0</sub>	H <sub>1</sub>	H <sub>t</sub>	Type	N°	M <sub>s</sub> [Nm]	M <sub>t</sub> [Nm]	F <sub>ax</sub> [kN]	P <sub>w</sub> [N/mm <sup>2</sup> ]	P <sub>n</sub> [N/mm <sup>2</sup> ]	
18 x 40	12	15	20	24	M4	6	5	218	24	297	135	
19 x 41	12	15	20	24	M4	6	5	230	24	282	130	
20 x 42	12	15	20	24	M4	7	5	283	28	312	150	
22 x 44	12	15	20	24	M4	7	5	311	28	284	140	
24 x 46	12	15	20	24	M4	7	5	340	28	260	135	
25 x 47	12	15	20	24	M4	7	5	354	28	250	135	
28 x 50	12	15	20	24	M4	9	5	508	36	287	160	
30 x 52	12	15	20	24	M4	9	5	545	36	268	155	
32 x 54	12	15	20	24	M4	9	5	581	36	251	150	
35 x 57	16	19	24	28	M4	10	5	707	40	191	115	
36 x 58	16	19	24	28	M4	10	5	727	40	186	115	
38 x 60	16	19	24	28	M4	11	5	844	44	194	125	
40 x 62	16	19	24	28	M4	11	5	888	44	184	120	
42 x 70	19	23	30	36	M6	8	17	1.533	73	243	145	
45 x 73	19	23	30	36	M6	8	17	1.643	73	226	140	
48 x 76	19	23	30	36	M6	8	17	1.752	73	212	135	
50 x 78	19	23	30	36	M6	8	17	1.825	73	204	130	
55 x 83	19	23	30	36	M6	8	17	2.008	73	185	125	
56 x 84	19	23	30	36	M6	8	17	2.044	73	182	120	
60 x 88	19	23	30	36	M6	9	17	2.463	82	191	130	
63 x 91	19	23	30	36	M6	9	17	2.586	82	182	125	
65 x 93	19	23	30	36	M6	9	17	2.668	82	176	125	
70 x 105	23	28	37	45	M8	8	41	4.718	135	222	150	
75 x 110	23	28	37	45	M8	8	41	5.055	135	207	140	
80 x 115	23	28	37	45	M8	8	41	5.392	135	194	135	
85 x 120	23	28	37	45	M8	8	41	5.729	135	183	130	
90 x 125	23	28	37	45	M8	10	41	7.583	169	216	155	
95 x 130	23	28	37	45	M8	10	41	8.004	169	205	150	

M <sub>s</sub>	Screw tightening torque	Nm
M <sub>t</sub>	Transmissible torque	Nm
F <sub>ax</sub>	Transmissible axial force	kN
P <sub>w</sub>	Pressure on shaft	N/mm <sup>2</sup>
P <sub>n</sub>	Pressure on hub	N/mm <sup>2</sup>

**IMPORTANT:** The screw tightening torque M<sub>s</sub> can be reduced by 40% of the value indicated in the table. M<sub>t</sub>, F<sub>ax</sub>, P<sub>w</sub>, P<sub>n</sub> decrease proportionally.

For further information or in case of needs of diameters or dimensions different to those in the table, please contact our Technical Department.

## SIT-LOCK® 15 internal locking device - self-centering

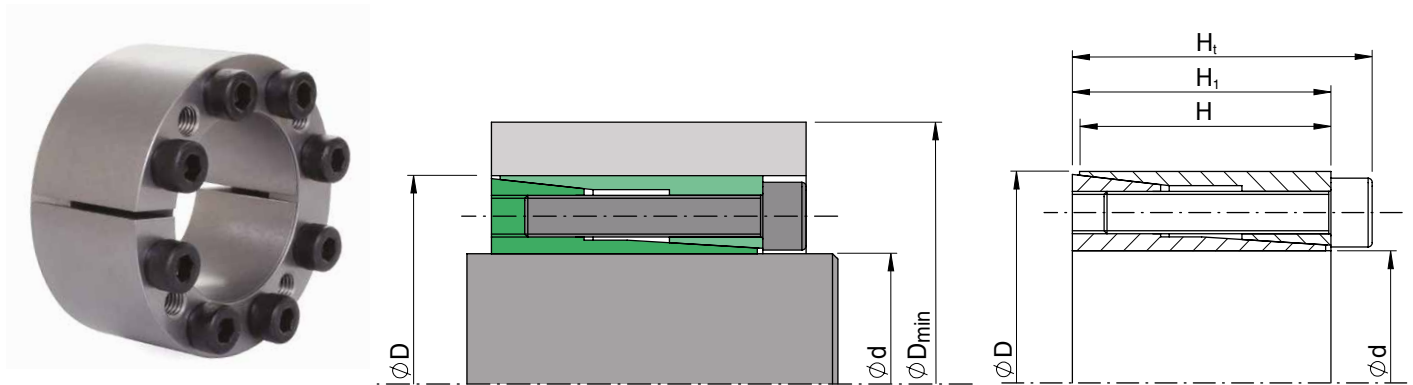

### Features

Composed of an inner ring and outer ring both with splits. This type of locking device is particularly suitable for applications that require excellent hub-to-shaft concentricity and perpendicularity. The table shows performance data for the following tolerances:

shaft d h8 - coupling seat on hub H8

***Do not use molybdenum disulphide-based oils or greases that reduce the coefficient of friction  $\mu$ . The values in the table are calculated with  $\mu$  0.12.***

### Hub to shaft centering

The SIT-LOCK® 15 locking device is self-centering so it does not require a centering base between the shaft and hub. This allows for hubs with reduced widths which saves on materials and leads to reduced costs.

### Installation with non-lubricated surfaces (dry)

The SIT-LOCK® 15 locking device is lubricated with oil before delivery to protect it from oxidation during storage. The values shown in the table have been calculated for applications with oiled contact surfaces. For dry installation, the values are:

$$M_t, F_{ax} +15\%$$

$$P_w, P_n -13\%$$

To get these values, the locking device must be completely disassembled and all its component surfaces must be cleaned with solvent. The shaft and hub contact surfaces must also be completely clean and oil-free.

### Axial displacement

When tightening the screws there is a hub to shaft axial displacement. The extent of axial displacement depends on the tolerances.

### Radial loads

The SIT-LOCK® 15 locking device is suitable for applications subject to medium radial loads. For further information, please contact our Technical Department.

### Surface finish

Normal surface finish is sufficient. The following values are recommended:

$$R_a \leq 3,2 \mu\text{m} - R_t \leq 16 \mu\text{m}$$

### Installation

The locking device is supplied ready to assemble. Clean the shaft contact surfaces thoroughly and apply oil. Mount the shaft, hub and locking device in the desired position.

Screw tightening sequence:

- tighten two diametrically opposed screws until the locking device surfaces make contact with the shaft and hub;
- tighten all screws to 50% of the screw tightening torque value  $M_s$  indicated in the table in a 'criss-cross' sequence;
- repeat to 100% of the  $M_s$  tightening torque indicated in the table;
- in continuous sequence, check that the tightening torque  $M_s$  has been achieved.

### Removal

Gradually loosen the clamping screws. Remove the clamping screws and insert them into the special removal threads on the inner ring flange.

Tighten the screws in a 'criss-cross' sequence until the locking device is released.

### Reusing the locking device

When reusing the locking device, check all the surfaces are clean and show no obvious signs of deformation or seizing. Clean and oil all surfaces and threads. Check the screws have not been deformed. Oil the screws and assemble the locking device as originally supplied.

## SIT-LOCK® 15 internal locking device - self-centering

Dimensions [mm]				Clamping screws DIN 912 12.9			Values with tolerances for shaft h8/hub H8				
d x D	H	H <sub>1</sub>	H <sub>t</sub>	Type	N°	M <sub>s</sub> [Nm]	M <sub>t</sub> [Nm]	F <sub>ax</sub> [kN]	P <sub>w</sub> [N/mm <sup>2</sup> ]	P <sub>n</sub> [N/mm <sup>2</sup> ]	
5 x 16	10,5	11	13,5	M2,5	3	1,2	8	3	157	50	
6 x 16	10,5	11	13,5	M2,5	3	1,2	9	3	131	50	
6,35 x 16	10,5	11	13,5	M2,5	3	1,2	10	3	124	50	
7 x 17	10,5	11	13,5	M2,5	3	1,2	11	3	112	45	
8 x 18	10,5	11	13,5	M2,5	3	1,2	12	3	98	45	
9 x 20	12,5	13	15	M2,5	4	1,2	19	4	98	45	
9,53 x 20	12,5	13	15	M2,5	4	1,2	20	4	93	45	
10 x 20	12,5	13	15,5	M2,5	4	1,2	21	4	88	45	
11 x 22	12,5	13	15,5	M2,5	4	1,2	23	4	80	40	
12 x 22	12,5	13	15,5	M2,5	4	1,2	25	4	73	40	
12,7 x 26	16,5	17	20	M3	4	2,2	38	6	76	35	
14 x 26	16,5	17	20	M3	4	2,2	42	6	69	35	
15 x 28	16,5	17	20	M3	4	2,2	45	6	65	35	
16 x 32	16,5	17	21	M4	4	4,9	85	11	107	55	
17 x 35	20,5	21	25	M4	4	4,9	90	11	81	40	
18 x 35	20,5	21	25	M4	4	4,9	95	11	76	40	
19 x 35	20,5	21	25	M4	4	4,9	101	11	72	40	
20 x 38	20,5	21	26	M5	4	10	173	17	112	60	
22 x 40	20,5	21	26	M5	4	10	190	17	102	55	
24 x 47	25	26	32	M6	4	17	294	25	108	55	
25 x 47	25	26	32	M6	4	17	306	25	104	55	
28 x 50	25	26	32	M6	6	17	514	37	139	80	
30 x 55	25	26	32	M6	6	17	551	37	130	70	
32 x 55	25	26	32	M6	6	17	587	37	122	70	
35 x 60	30	31	37	M6	8	17	856	49	124	70	
38 x 65	30	31	37	M6	8	17	929	49	114	65	
40 x 65	28	31	37	M6	8	17	978	49	116	70	
42 x 75	35	36	44	M8	6	41	1.424	68	122	70	
45 x 75	35	36	44	M8	6	41	1.526	68	114	70	
48 x 80	35	36	44	M8	8	41	2.170	90	143	85	
50 x 80	35	36	44	M8	8	41	2.260	90	137	85	

M<sub>s</sub> Screw tightening torque Nm  
M<sub>t</sub> Transmissible torque Nm  
F<sub>ax</sub> Transmissible axial force kN  
P<sub>w</sub> Pressure on shaft N/mm<sup>2</sup>  
P<sub>n</sub> Pressure on hub N/mm<sup>2</sup>

**IMPORTANT:** The screw tightening torque M<sub>s</sub> can be reduced by 40% of the value indicated in the table. M<sub>t</sub>, F<sub>ax</sub>, P<sub>w</sub>, P<sub>n</sub> decrease proportionally.

For further information or in case of needs of diameters or dimensions different to those in the table, please contact our Technical Department.

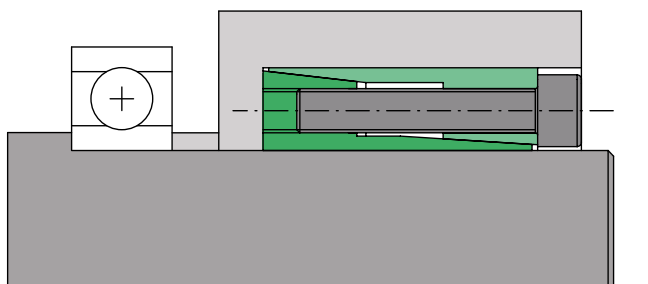

Application of a SIT-LOCK® 15 for locking a hub and simultaneously providing axial locking of a bearing. The values M<sub>t</sub>, F<sub>ax</sub>, P<sub>w</sub> and P<sub>n</sub> are reduced by 29% compared to the values indicated in the table. Using SIT-LOCK® 15 to lock a hub while axially locking a bearing. For further information, please contact our Technical Department.

## SIT-LOCK® 16 internal locking device - self-centering

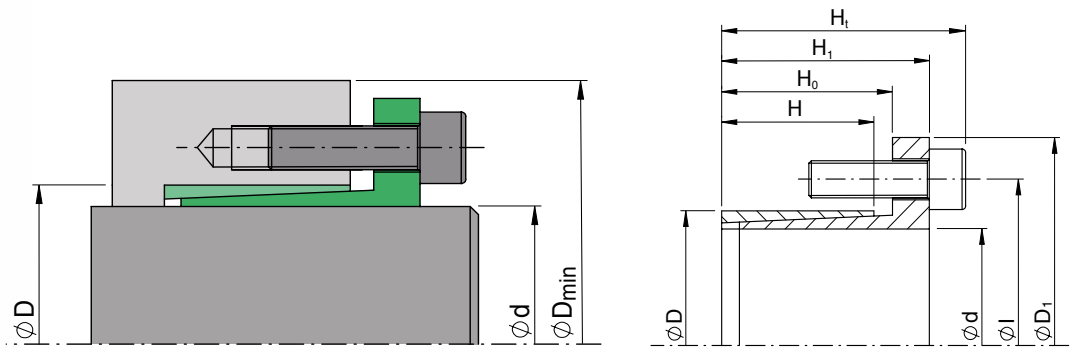

### Features

Composed of an inner ring and outer ring both with splits. This type of locking device is particularly suitable for applications that require excellent hub-to-shaft concentricity. It is also used for locking hubs with limited widths and diameters. The table shows performance data for the following tolerances:

shaft d h8 - coupling seat on hub H8

**Do not use molybdenum disulphide-based oils or greases that reduce the coefficient of friction  $\mu$ . The values in the table are calculated with  $\mu$  0.12.**

### Hub to shaft centering

The SIT-LOCK® 16 locking device is self-centering so it does not require a centering base between the shaft and hub. This allows for hubs with reduced widths which saves on materials and leads to reduced costs.

### Installation with non-lubricated surfaces (dry)

The SIT-LOCK® 16 locking device is lubricated with oil before delivery to protect it from oxidation during storage. The values shown in the table have been calculated for applications with oiled contact surfaces. For dry installation, the values are:

$M_t, F_{ax} +9\%$

$P_w, P_n -13\%$

To get these values, the locking device must be completely disassembled and all its component surfaces must be cleaned with solvent. The shaft and hub contact surfaces must also be completely clean and oil-free.

### Axial displacement

When tightening the screws there is a hub to shaft axial displacement. The axial displacement value depends on the locking device, shaft and hub seat tolerances.

### Clamping screws

**WARNING: the SIT-LOCK® 16 locking device comes without clamping screws as their length, being related to end-use, can't be set in advance. The values in the table are valid for 12.9 screws. For applications with 8.8 or 10.9 screws, the  $M_t - F_{ax} - P_w$  and  $P_n$  values will be lower. For further information, please contact our Technical Department.**

### Surface finish

Normal surface finish is sufficient. The following values are recommended:

$R_a \leq 3,2 \mu\text{m} - R_t \leq 16 \mu\text{m}$

### Installation

Clean the shaft contact surfaces thoroughly and apply oil. Mount the shaft, hub and locking device in the desired position.

Screw tightening sequence:

- tighten two diametrically opposed screws until the locking device surfaces make contact with the shaft and hub;
- tighten all screws to 50% of the screw tightening torque value  $M_s$  indicated in the table in a 'criss-cross' sequence;
- repeat to 100% of the  $M_s$  tightening torque indicated in the table;
- in continuous sequence, check that the tightening torque  $M_s$  has been achieved.

### Removal

Gradually loosen the clamping screws. Remove the clamping screws and insert them into the special removal threads on the inner ring flange.

Tighten the screws in a 'criss-cross' sequence until the locking device is released.

### Reusing the locking device

When reusing the locking device, check all the surfaces are clean and show no obvious signs of deformation or seizing. Clean and oil all surfaces and threads. Check the screws have not been deformed. Oil the screws and assemble the locking device as originally supplied.

## SIT-LOCK® 16 internal locking device - self-centering

Dimensions [mm]							Clamping screws DIN 912 12.9 - NOT INCLUDED			Values with tolerances for shaft h8/hub H8			
d x D	H	H <sub>0</sub>	H <sub>1</sub>	H <sub>t</sub>	l	D <sub>1</sub>	Type	N°	M <sub>s</sub> [Nm]	M <sub>t</sub> [Nm]	F <sub>ax</sub> [kN]	P <sub>w</sub> [N/mm <sup>2</sup> ]	P <sub>n</sub> [N/mm <sup>2</sup> ]
14 x 25	16	20	26	30	33	42	M4	4	5	113	16	191	105
15 x 25	16	20	26	30	33	42	M4	4	5	121	16	178	105
16 x 25	16	20	26	30	33	42	M4	4	5	129	16	167	105
18 x 25	16	20	26	30	33	42	M4	4	5	145	16	149	105
19 x 25	16	20	26	30	33	42	M4	4	5	153	16	141	105
20 x 30	16	20	26	31	39	50	M5	4	10	258	26	214	145
22 x 30	16	20	26	31	39	50	M5	4	10	284	26	195	145
24 x 30	16	20	26	31	39	50	M5	4	10	310	26	179	145
25 x 36	16	20	26	31	45	55	M5	4	10	323	26	171	120
28 x 36	16	20	26	31	45	55	M5	4	10	361	26	153	120
30 x 36	16	20	26	31	45	55	M5	4	10	387	26	143	120
32 x 42	16	20	28	33	51	62	M5	4	10	413	26	134	100
35 x 42	16	20	28	33	51	62	M5	4	10	452	26	122	100
38 x 44	16	20	28	34	54	66	M6	4	17	694	37	159	135
40 x 48	16	20	28	34	58	70	M6	4	17	730	37	151	125
42 x 48	16	20	28	34	58	70	M6	4	17	767	37	144	125
45 x 55	20	25	35	43	67	82	M8	4	41	1.517	67	199	165
48 x 55	20	25	35	43	67	82	M8	4	41	1.618	67	186	165
50 x 62	20	25	35	43	74	89	M8	4	41	1.685	67	179	145
55 x 62	20	25	35	43	74	89	M8	4	41	1.854	67	163	145
60 x 72	20	25	35	43	84	99	M8	4	41	2.022	67	149	125
65 x 72	20	25	35	43	84	99	M8	4	41	2.191	67	138	125

M<sub>s</sub> Screw tightening torque                      Nm  
M<sub>t</sub> Transmissible torque                              Nm  
F<sub>ax</sub> Transmissible axial force                      kN  
P<sub>w</sub> Pressure on shaft                                  N/mm<sup>2</sup>  
P<sub>n</sub> Pressure on hub                                      N/mm<sup>2</sup>

**IMPORTANT:** The screw tightening torque M<sub>s</sub> can be reduced by 40% of the value indicated in the table. M<sub>t</sub>, F<sub>ax</sub>, P<sub>w</sub>, P<sub>n</sub> decrease proportionally.

For further information or in case of needs of diameters or dimensions different to those in the table, please contact our Technical Department.

Internal - self-centering

## SIT-LOCK® 18 internal locking device - self-centering

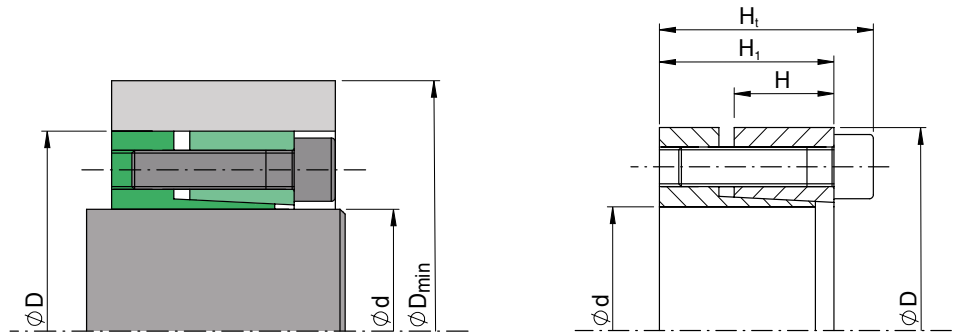

### Features

Composed of an inner ring and outer ring both with splits. This type of locking device is particularly suitable for applications that require torque transmission while generating an axial force to axially lock a bearing, washer or any other axially clamped part. The table shows performance data for the following tolerances:

shaft d h8 - coupling seat on hub H8

**Do not use molybdenum disulphide-based oils or greases that reduce the coefficient of friction  $\mu$ . The values in the table are calculated with  $\mu$  0.12.**

**The table shows the  $M_t$  -  $F_{ax}$  -  $P_w$  and  $P_n$  values for applications where the hub axially locks a part. For applications that do not require this function, SIT-LOCK® 5A or 5B is recommended.**

### Hub to shaft centering

The SIT-LOCK® 18 locking device is self-centering so it does not require a centering base between the shaft and hub. This allows for hubs with reduced widths which saves on materials and leads to reduced costs.

### Installation with non-lubricated surfaces (dry)

The SIT-LOCK® 18 locking device is lubricated with oil before delivery to protect it from oxidation during storage. The values shown in the table have been calculated for applications with oiled contact surfaces. For dry installation, the values are:

$M_t, F_{ax}$  +5%

$P_w, P_n$  -16%

To get these values, the locking device must be completely disassembled and all its component surfaces must be cleaned with solvent. The shaft and hub contact surfaces must also be completely clean and oil-free.

### Axial displacement

When tightening the screws there is a hub to shaft axial displacement. The extent of axial displacement depends on the tolerances. Axial displacement generates a force on the axially clamped part that is equal to the axial force  $F_{ax}$  in the table.

### Radial loads

The SIT-LOCK® 18 locking device is suitable for applications subject to high radial loads. For further information, please contact our Technical Department.

### Surface finish

Normal surface finish is sufficient. The following values are recommended:

$R_a \leq 3,2 \mu m$  -  $R_t \leq 16 \mu m$

### Installation

The locking device is supplied ready to assemble. Clean the shaft contact surfaces thoroughly and apply oil. Mount the shaft, hub and locking device in the desired position. Position the hub axially against the part to be axially clamped.

Screw tightening sequence:

- tighten two diametrically opposed screws until the locking device surfaces make contact with the shaft and hub;
- tighten all screws to 50% of the screw tightening torque value  $M_s$  indicated in the table in a 'criss-cross' sequence;
- repeat to 100% of the  $M_s$  tightening torque indicated in the table;
- in continuous sequence, check that the tightening torque  $M_s$  has been achieved.

### Removal

Gradually loosen the clamping screws. Remove the clamping screws and insert them into the special removal threads on the outer ring. Tighten the screws in a 'criss-cross' sequence until the locking device is released.

### Reusing the locking device

When reusing the locking device, check all the surfaces are clean and show no obvious signs of deformation or seizing. Clean and oil all surfaces and threads. Check the screws have not been deformed. Oil the screws and assemble the locking device as originally supplied.

## SIT-LOCK® 18 internal locking device - self-centering

Dimensions [mm]				Clamping screws DIN 912 12.9			Values with tolerances for shaft h8/hub H8			
d x D	H	H <sub>1</sub>	H <sub>t</sub>	Type	N°	M <sub>s</sub> [Nm]	M <sub>t</sub> [Nm]	F <sub>ax</sub> [kN]	P <sub>w</sub> [N/mm <sup>2</sup> ]	P <sub>n</sub> [N/mm <sup>2</sup> ]
20 x 47	14	28	34	M6	5	17	456	46	432	185
22 x 47	14	28	34	M6	5	17	502	46	393	185
24 x 50	14	28	34	M6	6	17	656	55	432	205
25 x 50	14	28	34	M6	6	17	684	55	415	205
30 x 55	14	28	34	M6	6	17	821	55	346	190
35 x 60	14	28	34	M6	8	17	1.278	73	395	230
38 x 65	14	28	34	M6	8	17	1.387	73	364	215
40 x 65	14	28	34	M6	8	17	1.460	73	346	215
42 x 75	18	35	43	M8	7	41	2.476	118	414	230
45 x 75	18	35	43	M8	7	41	2.653	118	386	230
50 x 80	18	35	43	M8	7	41	2.948	118	348	215
55 x 85	18	35	43	M8	8	41	3.707	135	361	235
60 x 90	18	35	43	M8	8	41	4.044	135	331	220
65 x 95	18	35	43	M8	9	41	4.927	152	344	235
70 x 110	24	46	56	M10	8	83	7.490	214	338	215

M<sub>s</sub> Screw tightening torque Nm  
M<sub>t</sub> Transmissible torque Nm  
F<sub>ax</sub> Transmissible axial force kN  
P<sub>w</sub> Pressure on shaft N/mm<sup>2</sup>  
P<sub>n</sub> Pressure on hub N/mm<sup>2</sup>

**IMPORTANT:** The screw tightening torque M<sub>s</sub> can be reduced by 40% of the value indicated in the table. M<sub>t</sub>, F<sub>ax</sub>, P<sub>w</sub>, P<sub>n</sub> decrease proportionally.

For further information or in case of needs of diameters or dimensions different to those in the table, please contact our Technical Department.

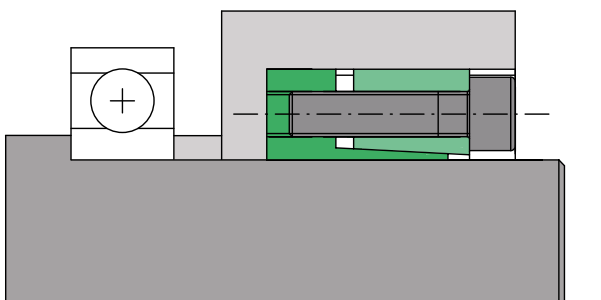

Application of a SIT-LOCK® 18 for locking a hub and simultaneously providing axial locking of a bearing. The values M<sub>t</sub>, F<sub>ax</sub>, P<sub>w</sub> and P<sub>n</sub> are reduced by 38% compared to the values indicated in the table. For further information, please contact our Technical Department.

## SIT-LOCK® 13 internal locking device - self-centering

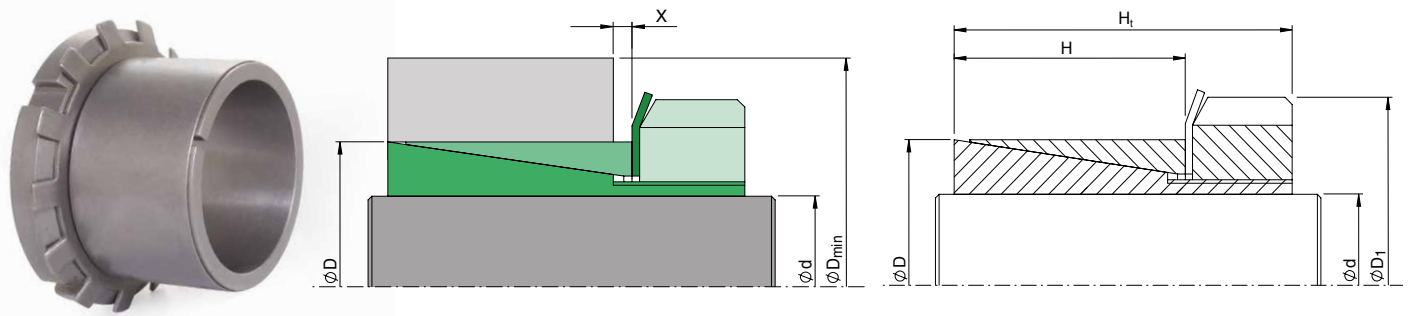

### Features

Composed of two tapered rings, an inner ring, a splits outer ring and a ring nut with locking washer. It is suitable for applications that require reduced radial and axial dimensions. Particularly suitable for applications without screw tightening space. The ring nut can actually be tightened from above using a special key of very reduced size. The table shows performance data for the following tolerances:

shaft d h8 - coupling seat on hub H8

**Do not use molybdenum disulphide-based oils or greases that reduce the coefficient of friction  $\mu$ . The values in the table are calculated with  $\mu$  0.12.**

### Hub to shaft centering

The SIT-LOCK® 13 locking device is self-centering so it does not require a centering base between the shaft and hub.

### Axial displacement

**Application 1:** When tightening the ring nut, there is no hub to shaft axial displacement. The values in the table are valid for application 1.

**Application 2:** When tightening the ring nut, there is hub to shaft axial displacement.  $M_t$ ,  $F_{ax}$ ,  $P_w$  and  $P_n$  values increase by 55% compared to the values shown in the table.

### Surface finish

The following values are recommended:

$$R_a \leq 3,2 \mu\text{m} - R_t \leq 16 \mu\text{m}$$

**Considering that using the SIT-LOCK® 2 model requires: tight tolerances, precise surface finishes, and additional accessory costs (flange, screw threads), we recommend using SIT-LOCK® 13.**

### Installation

Clean the shaft and hub contact surfaces thoroughly. Insert the shaft, the hub and SIT-LOCK® 13 locking device in the desired position.

Nut tightening sequence:

- tighten the ring nut to the tightening torque  $M_s$  indicated in the table;
- lock the ring nut using the appropriate locking washer as shown in the figure.

### Removal

Unlock the ring nut from the locking washer. Loosen the ring nut until the clamping set is fully removed.

**CAUTION:** The SIT-LOCK® 13 taper angle is approximately  $4^\circ$ . As the angle is less than the friction angle, removal may not be guaranteed. For applications that require removal, SIT-LOCK® 9 is recommended.

### Reusing the locking device

When reusing the locking device, check all the surfaces are clean and show no obvious signs of deformation or seizing. Clean and oil all surfaces and threads. Check the ring nut and washer have not been deformed. Oil the screws and assemble the locking device as originally supplied.

## SIT-LOCK® 13 internal locking device - self-centering

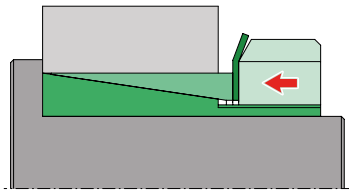

Application 1  
 $M_t, F_{ax}, P_w, P_n$   
 values as indicated in the table

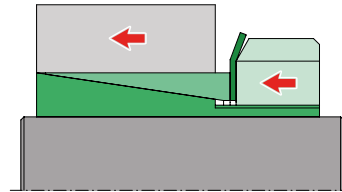

Application 2  
 $M_t, F_{ax}, P_w, P_n$   
 55% greater than the values indicated in the table

Dimensions [mm]					Ring nut		Ring nut tightening torque	Values with tolerances for shaft h8/hub H8			
d x D	H	H <sub>t</sub>	D <sub>1</sub>	X	Type	Thread	M <sub>s</sub> [Nm]	M <sub>t</sub> [Nm]	F <sub>ax</sub> [kN]	P <sub>w</sub> [N/mm <sup>2</sup> ]	P <sub>n</sub> [N/mm <sup>2</sup> ]
14 x 25	23	31	32	3	KM4	M20x1	95	66	9,2	87	50
15 x 25	23	31	32	3	KM4	M20x1	95	72	9,2	82	50
17 x 25	23	31	32	3	KM4	M20x1	95	81	9,2	74	50
18 x 30	24	33	38	3	KM5	M25x1,5	160	103	11,4	82	50
19 x 30	24	33	38	3	KM5	M25x1,5	160	108	11,4	77	50
20 x 30	24	33	38	3	KM5	M25x1,5	160	115	11,4	73	50
24 x 35	29	38	45	4	KM6	M30x1,5	220	183	15,2	67	45
25 x 35	29	38	45	4	KM6	M30x1,5	220	190	15,2	62	45
28 x 40	34	44	52	4	KM7	M35x1,5	340	257	18,3	57	40
30 x 40	34	44	52	4	KM7	M35x1,5	340	275	18,3	53	40
32 x 45	34	45	58	4	KM8	M40x1,5	480	360	22,5	62	45
35 x 45	34	45	58	4	KM8	M40x1,5	480	393	22,5	57	45
36 x 45	34	45	58	4	KM8	M40x1,5	480	404	22,5	56	45
38 x 50	35	46	65	5	KM9	M45x1,5	680	507	26,7	59	45
40 x 50	35	46	65	5	KM9	M45x1,5	680	534	26,7	57	45
45 x 55	35	47	70	5	KM10	M50x1,5	870	700	31	62	50
48 x 60	35	47	75	5	KM11	M55x2	970	863	36	62	50
50 x 60	35	47	75	5	KM11	M55x2	970	898	36	60	50
55 x 65	36	48	80	5	KM12	M60x2	1.100	1.055	38,5	62	55
60 x 70	36	50	85	5	KM13	M65x2	1.300	1.398	46,6	67	60

M<sub>s</sub> Screw tightening torque      Nm  
 M<sub>t</sub> Transmissible torque      Nm  
 F<sub>ax</sub> Transmissible axial force      kN  
 P<sub>w</sub> Pressure on shaft      N/mm<sup>2</sup>  
 P<sub>n</sub> Pressure on hub      N/mm<sup>2</sup>

For larger diameters or dimensions different to those in the table, please contact our Technical Department.



INTERNAL LOCKING DEVICE - NOT SELF-CENTERING

A photograph showing several metallic components of an internal locking device. The components are arranged on a white surface, with some showing internal locking mechanisms and others showing external flanges with bolts.

# INTERNAL LOCKING DEVICE NOT SELF-CENTERING

## SIT-LOCK® 1 internal locking device - not self-centering

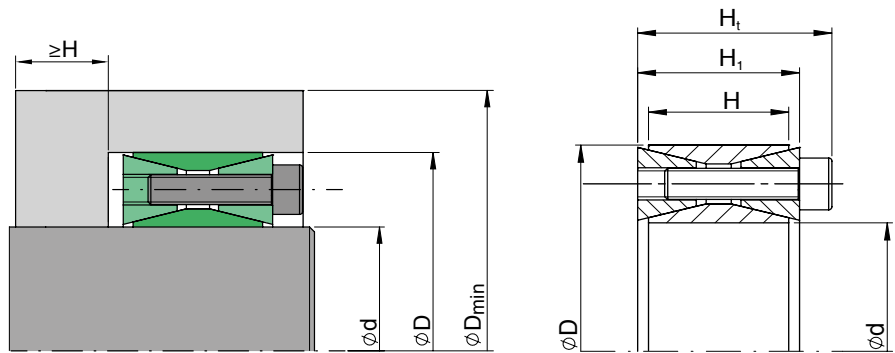

### Features

Consisting of two tapered rings with splits, an inner ring and an outer ring, it is particularly suitable for applications that require extensive tolerance. The table shows performance data for the following tolerances:

shaft d h7 - coupling seat on hub H7

shaft d h11 - coupling seat on hub H11

The decrease in performance with h11/H11 tolerances is due to a partial loss of the radial force developed which is required to deform the tapers that are not split.

**Do not use molybdenum disulphide-based oils or greases that reduce the coefficient of friction  $\mu$ . The values in the table are calculated with  $\mu$  0.12.**

### Hub to shaft centering

The SIT-LOCK® 1 locking device is not self-centering so it requires a centering base between the shaft and hub. Where optimum concentricity is required, a centering base with a width  $\geq H$  is recommended.

### Installation with non-lubricated surfaces (dry)

The SIT-LOCK® 1 locking device is lubricated with oil before delivery to protect it from oxidation during storage. The values shown in the table have been calculated for applications with oiled contact surfaces. For dry installation, the values are:

$M_t, F_{ax} +15\%$

$P_w, P_n -8\%$

To get these values, the locking device must be completely disassembled and all component surfaces must be cleaned with solvent. The shaft and hub contact surfaces must also be completely dry.

### Axial displacement

When tightening the screws there is no hub to shaft axial displacement.

### High radial loads

The SIT-LOCK® 1 locking device is not suitable for high radial loads. The taper angle, which is two times greater than the friction angle  $\varphi$ , would develop an additional axial force on the screws, which could lead to them breaking. For these types of applications, please contact our Technical Department.

### Surface finish

Normal surface finish is sufficient. The following values are recommended:

$R_a \leq 3,2 \mu\text{m} - R_t \leq 16 \mu\text{m}$

### Applications with more than one SIT-LOCK® 1 device

Where two or more type 1 locking devices are mounted in a row, the total transmissible torque  $M_t$  is:

1 device  $M_t = M_t$  indicated in catalogue  
 2 devices  $M_t = M_t$  indicated in catalogue  $\cdot 1,9$   
 3 devices  $M_t = M_t$  indicated in catalogue  $\cdot 2,7$   
 4 devices  $M_t = M_t$  indicated in catalogue  $\cdot 3,6$

### Installation

The locking device is supplied ready to assemble. Clean the hub and shaft contact surfaces thoroughly and apply oil. Mount the shaft, hub and locking device in the desired position.

Screw tightening sequence:

- tighten two diametrically opposed screws until the locking device surfaces make contact with the shaft and hub;
- tighten all screws to 50% of the screw tightening torque value  $M_s$  indicated in the table in a 'criss-cross' sequence
- repeat to 100% of the  $M_s$  tightening torque indicated in the table;
- in continuous sequence, check that the tightening torque  $M_s$  has been achieved.

### Removal

Gradually loosen the clamping screws. If necessary, lightly tap the screws with a hammer.

# SIT-LOCK® 1 internal locking device - not self-centering

Dimensions [mm]				Clamping screws DIN 912 12.9			Values with tolerances for shaft h11/hub H11				Values with tolerances for shaft h7/hub H7			
d x D	H	H <sub>1</sub>	H <sub>t</sub>	Type	N°	M <sub>s</sub> [Nm]	M <sub>t</sub> [Nm]	F <sub>ax</sub> [kN]	P <sub>w</sub> [N/mm <sup>2</sup> ]	P <sub>n</sub> [N/mm <sup>2</sup> ]	Mt [Nm]	Fax [kN]	Pw [N/mm <sup>2</sup> ]	Pn [N/mm <sup>2</sup> ]
17 x 47	17	20	26	M6	8	17	281	33	303	110	315	37	341	125
18 x 47	17	20	26	M6	8	17	295	33	284	110	336	37	323	125
19 x 47	17	20	26	M6	8	17	311	33	268	110	355	37	307	125
20 x 47	17	20	26	M6	8	17	325	33	254	110	375	38	293	125
22 x 47	17	20	26	M6	8	17	361	33	232	110	410	37	265	125
24 x 50	17	20	26	M6	8	17	396	33	214	105	450	38	244	115
25 x 50	17	20	26	M6	8	17	410	33	205	100	465	37	232	115
28 x 55	17	20	26	M6	10	17	574	41	229	115	654	47	260	135
30 x 55	17	20	26	M6	10	17	615	41	213	115	699	47	243	130
32 x 60	17	20	26	M6	12	17	784	49	239	130	894	56	273	145
35 x 60	17	20	26	M6	12	17	859	49	219	130	980	56	250	145
38 x 65	17	20	26	M6	14	17	1.091	57	236	140	1.239	65	268	155
40 x 65	17	20	26	M6	14	17	1.144	57	223	135	1.304	65	254	155
42 x 75	20	24	32	M8	12	41	1.861	89	280	155	2.171	103	326	185
45 x 75	20	24	32	M8	12	41	1.996	89	261	155	2.327	103	305	185
48 x 80	20	24	32	M8	12	41	2.126	89	245	145	2.482	103	286	170
50 x 80	20	24	32	M8	12	41	2.215	89	235	145	2.585	103	274	170
55 x 85	20	24	32	M8	14	41	2.846	104	250	160	3.322	121	291	190
60 x 90	20	24	32	M8	14	41	3.102	103	228	150	3.621	121	267	180
65 x 95	20	24	32	M8	16	41	3.842	118	241	165	4.479	138	281	190
70 x 110	24	28	38	M10	14	83	5.611	160	253	160	6.706	192	303	195
75 x 115	24	28	38	M10	14	83	6.011	160	236	155	7.185	192	282	185
80 x 120	24	28	38	M10	14	83	6.412	160	221	150	7.668	192	265	175
85 x 125	24	28	38	M10	16	83	7.786	183	238	160	9.308	219	285	195
90 x 130	24	28	38	M10	16	83	8.249	183	225	155	9.851	219	269	185
95 x 135	24	28	38	M10	18	83	9.790	206	240	170	11.704	246	287	200
100 x 145	26	33	45	M12	14	145	11.315	226	231	160	13.945	279	285	195
110 x 155	26	33	45	M12	14	145	12.447	226	210	150	15.340	279	259	185
120 x 165	26	33	45	M12	16	145	15.516	259	220	160	19.128	319	271	195
130 x 180	34	38	50	M12	20	145	21.008	323	194	140	25.903	399	239	175
140 x 190	34	38	50	M12	22	145	24.892	356	198	145	30.681	438	244	180
150 x 200	34	38	50	M12	24	145	29.085	388	202	150	35.858	478	249	185
160 x 210	34	38	50	M12	26	145	33.616	420	205	155	41.440	518	253	190
170 x 225	38	44	58	M14	22	230	40.426	476	195	150	51.119	601	247	185
180 x 235	38	44	58	M14	24	230	46.692	519	201	155	59.040	656	254	195
190 x 250	46	52	66	M14	28	230	57.504	605	184	140	72.713	765	232	175
200 x 260	46	52	66	M14	30	230	64.860	649	187	145	82.010	820	236	180
220 x 285	50	56	72	M16	26	355	84.601	769	185	145	108.669	988	238	185
240 x 305	50	56	72	M16	30	355	106.488	887	196	155	136.776	1.140	252	200
260 x 325	50	56	72	M16	34	355	130.741	1.006	205	165	167.921	1.292	264	210
280 x 355	60	66	84	M18	32	485	157.360	1.124	177	140	204.792	1.463	231	180
300 x 375	60	66	84	M18	36	485	189.690	1.265	186	150	246.870	1.646	243	195
320 x 405	72	78	98	M20	36	690	259.696	1.623	187	150	341.600	2.135	246	195
340 x 425	72	78	98	M20	36	690	275.927	1.623	176	140	362.950	2.135	231	185
360 x 455	84	90	112	M22	36	930	360.738	2.004	176	140	478.386	2.658	233	185
380 x 475	84	90	112	M22	36	930	380.779	2.004	167	135	504.963	2.658	221	175
400 x 495	84	90	112	M22	36	930	400.820	2.004	158	130	531.540	2.658	210	170
420 x 515	84	90	112	M22	40	930	467.628	2.227	167	135	620.130	2.953	222	180
440 x 545	96	102	126	M24	40	1.200	557.304	2.533	159	130	750.222	3.410	214	175
460 x 565	96	102	126	M24	40	1.200	582.636	2.533	152	125	784.323	3.410	205	165
480 x 585	96	102	126	M24	42	1.200	638.376	2.660	153	125	859.368	3.581	206	170
500 x 605	96	102	126	M24	44	1.200	696.650	2.787	154	125	937.775	3.751	207	170
520 x 630	96	102	126	M24	45	1.200	740.974	2.850	151	125	997.464	3.836	204	170
540 x 650	96	102	126	M24	45	1.200	769.473	2.850	146	120	1.035.828	3.836	196	165
560 x 670	96	102	126	M24	48	1.200	851.172	3.040	150	125	1.145.816	4.092	202	170
580 x 690	96	102	126	M24	50	1.200	918.285	3.167	151	125	1.236.154	4.263	203	170
600 x 710	96	102	126	M24	50	1.200	949.950	3.167	146	125	1.278.780	4.263	196	165

**IMPORTANT:** The screw tightening torque M<sub>s</sub> can be reduced by 40% of the value indicated in the table. M<sub>t</sub>, F<sub>ax</sub>, P<sub>w</sub>, P<sub>n</sub> decrease proportionally. For further information, please contact our Technical Department.

Internal - not self-centering

## SIT-LOCK® 9 internal locking device - not self-centering

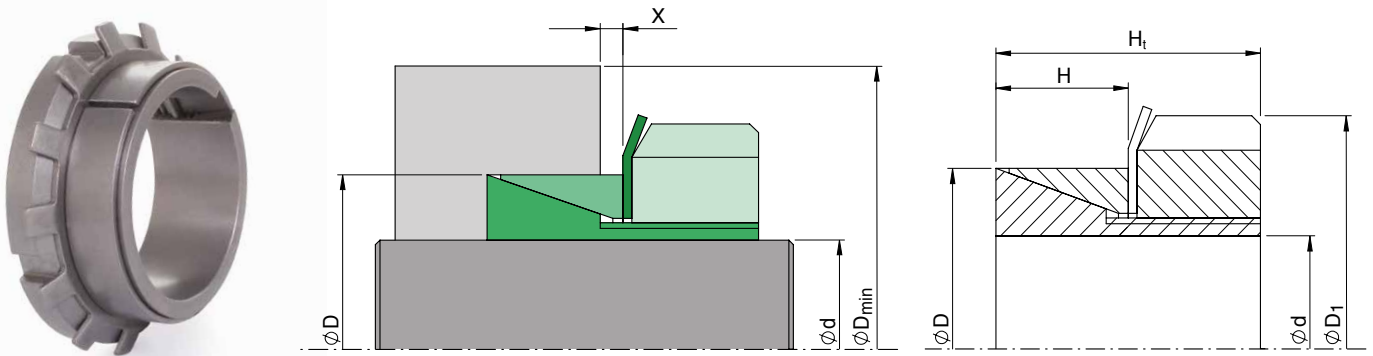

### Features

Composed of two tapered rings, an inner ring, a split outer ring and a ring nut with locking washer. It is suitable for applications that require reduced radial and axial dimensions. Particularly suitable for applications without screw tightening space. The ring nut can actually be tightened from above using a special key of very reduced size. The table shows performance data for the following tolerances:

shaft d h8 - coupling seat on hub H8

**Do not use molybdenum disulphide-based oils or greases that reduce the coefficient of friction  $\mu$ . The values in the table are calculated with  $\mu 0.12$ .**

### Hub to shaft centering

The SIT-LOCK® 9 locking device is not self-centering so it requires a centering base between the shaft and hub. A centering width of  $\geq 2 \cdot H1$  is recommended.

### Axial displacement

**Application 1:** When tightening the ring nut, there is no hub to shaft axial displacement. The values in the table are valid for application 1.

**Application 2:** When tightening the ring nut, there is hub to shaft axial displacement. The  $M_t$ ,  $F_{ax}$ ,  $P_w$  and  $P_n$  values increase by 28% compared to the values shown in the table.

### Surface finish

The following values are recommended:

$R_a \leq 3,2 \mu\text{m}$  -  $R_t \leq 16 \mu\text{m}$

**Considering that using the SIT-LOCK® 2 model requires tight tolerances, precise surface finishes, and additional accessory costs (flange, screw threads), we recommend using SIT-LOCK® 9.**

### Installation

Clean the shaft and hub contact surfaces thoroughly. Insert the shaft, the hub and SIT-LOCK® 9 locking device in the desired position.

Nut tightening sequence:

- tighten the ring nut to the tightening torque  $M_s$  indicated in the table;
- lock the ring nut using the appropriate locking washer as shown in the figure.

### Removal

- unlock the ring nut from the locking washer. Loosen the ring nut until the locking device is fully removed;
- removal may be difficult in some applications because there are no disassembly threads as a ring nut is used for locking.

### Reusing the locking device

When reusing the locking device, check all the surfaces are clean and show no obvious signs of deformation or seizing. Clean and oil all surfaces and threads. Check the ring nut and washer have not been deformed. Oil the screws and assemble the locking device as originally supplied.

## SIT-LOCK® 9 internal locking device - not self-centering

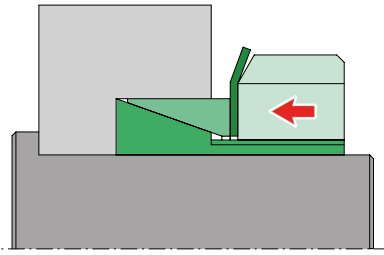

Application 1  
 $M_t, F_{ax}, P_w, P_n$   
 values as indicated in the table

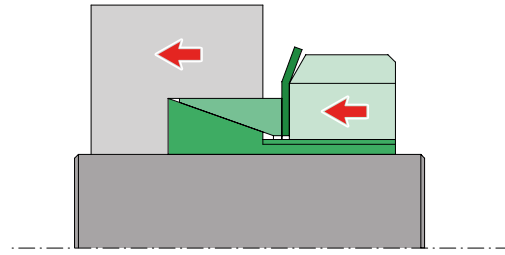

Application 2  
 $M_t, F_{ax}, P_w, P_n$   
 greater than +28% of values in the table

Dimensions [mm]					Ring nut		Ring nut tightening torque	Values with tolerances for shaft h8/hub H8			
d x D	H	H <sub>t</sub>	D <sub>1</sub>	X	Type	Thread	M <sub>s</sub> [Nm]	M <sub>t</sub> [Nm]	F <sub>ax</sub> [kN]	P <sub>w</sub> [N/mm <sup>2</sup> ]	P <sub>n</sub> [N/mm <sup>2</sup> ]
14 x 25	9	17	32	2,5	KM4	M20x1	95	45	6	238	130
15 x 25	9	17	32	2,5	KM4	M20x1	95	56	6	220	130
16 x 25	9	17	32	2,5	KM4	M20x1	95	51	6	207	130
17 x 26	9	18	38	2,5	KM5	M25x1,5	160	65	7,1	234	135
18 x 26	9	18	38	2,5	KM5	M25x1,5	160	69	7,1	221	155
18 x 30	9	17,5	38	2,5	KM5	M25x1,5	160	69	7,1	221	135
19 x 30	9	18	38	2,5	KM5	M25x1,5	160	73	8,3	210	135
20 x 30	9	18	38	2,5	KM5	M25x1,5	160	78	8,3	198	130
22 x 32	9	18	45	2,5	KM6	M30x1,5	220	114	9,5	240	165
24 x 35	9	18	45	2,5	KM6	M30x1,5	220	125	10,7	220	150
25 x 35	9	18	45	2,5	KM6	M30x1,5	220	130	10,7	211	150
28 x 36	10	18	52	3	KM7	M35x1,5	340	178	11,9	209	160
28 x 40	9	18	52	3	KM7	M35x1,5	340	178	11,9	209	145
30 x 40	11	20	52	3	KM7	M35x1,5	340	190	13,1	195	145
32 x 42	11	22	58	3	KM8	M40x1,5	480	250	15,5	200	150
35 x 45	11	22	58	3	KM8	M40x1,5	480	250	15,5	200	145
36 x 45	11	22	58	3	KM8	M40x1,5	480	285	15,5	177	145
38 x 48	14	25	65	4	KM9	M45x1,5	680	345	16,7	150	120
40 x 50	14	25	65	4	KM9	M45x1,5	680	369	17,8	143	115
40 x 52	14	25	65	4	KM9	M45x1,5	680	369	17,8	143	110
42 x 55	14	26	70	4	KM10	M50x1,5	870	440	20,2	156	120
45 x 55	14	26	70	4	KM10	M50x1,5	870	476	21,4	145	120
48 x 62	14	26	75	4	KM11	M55x2	970	595	25	160	125
50 x 60	14	26	75	4	KM11	M55x2	970	618	25	155	130
50 x 62	14	26	75	4	KM11	M55x2	970	618	25	155	125
55 x 65	15	27	80	4	KM12	M60x2	1.100	725	26,1	122	105
55 x 68	15	27	80	4	KM12	M60x2	1.100	725	26,1	122	100
56 x 68	15	27	80	4	KM12	M60x2	1.100	737	26,1	120	95
60 x 70	15	29	85	4	KM13	M65x2	1.300	952	32,1	134	110
60 x 73	15	29	85	4	KM13	M65x2	1.300	952	32,1	134	110
63 x 79	17	31	92	4	KM14	M70x2	1.600	1.166	36,9	127	100
65 x 79	17	31	92	4	KM14	M70x2	1.600	1.200	36,9	124	100
70 x 84	17	31	98	4	KM15	M75x2	2.000	1.475	41,6	131	110

$M_s$  Screw tightening torque      Nm  
 $M_t$  Transmissible torque      Nm  
 $F_{ax}$  Transmissible axial force      kN  
 $P_w$  Pressure on shaft      N/mm<sup>2</sup>  
 $P_n$  Pressure on hub      N/mm<sup>2</sup>

For dimensions not included in the table, please contact our Technical Department.

Internal - not self-centering

## SIT-LOCK® 2 internal locking device - not self-centering

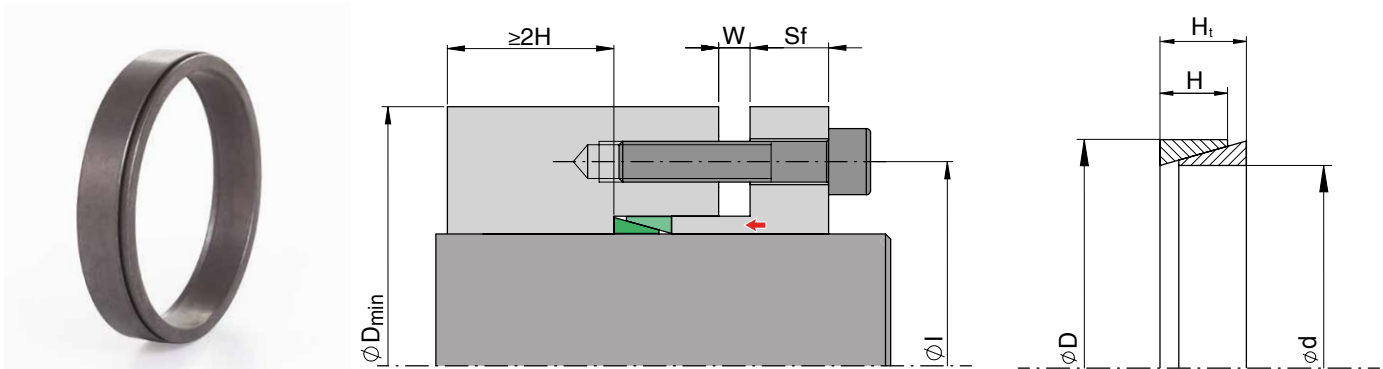

### Features

Composed of two tapered rings, it is suitable for applications that require smaller dimensions. The table shows performance data for the following tolerances:

shaft d h6 - hub seat H7 for  $d \leq 40$  mm

shaft d h8 - hub seat H8 for  $d \geq 42$  mm

**Do not use molybdenum disulphide-based oils or greases that reduce the coefficient of friction  $\mu$ . The values in the table are calculated with  $\mu$  0.12.**

### Hub to shaft centering

The SIT-LOCK® 2 locking device is not self-centering so it requires a centering base between the shaft and hub. A centering width of  $\geq 2 \cdot H$  is recommended.

### Axial displacement

**Application 1:** When tightening the screws, there is no hub to shaft axial displacement. The values in the table are valid for application 1.

**Application 2:** When tightening the screws, there is hub to shaft axial displacement. The  $M_t$ ,  $F_{ax}$ ,  $P_w$  and  $P_n$  values increase by 28% compared to the values shown in the table.

### Surface finish

The following values are recommended:

$$R_a \leq 1 \mu\text{m} - R_t \leq 6 \mu\text{m}$$

### Applications with more than one SIT-LOCK® 2 device

Where two or more SIT-LOCK® 2 locking devices are mounted in a row, the total transmissible torque  $M_t$  is:

- 1 device  $M_t = M_t$  indicated in catalogue
- 2 devices  $M_t = M_t$  indicated in catalogue  $\cdot 1,55$
- 3 devices  $M_t = M_t$  indicated in catalogue  $\cdot 1,86$
- 4 devices  $M_t = M_t$  indicated in catalogue  $\cdot 2,03$

### SIT-LOCK® 2 split version

The SIT-LOCK® 2 is available in a split version on request. In this case, consider the table force  $P_0$  equal to 0.

**Considering that using the SIT-LOCK® 2 model requires tight tolerances, precise surface finishes, and additional accessory costs (flange, screw threads), we recommend using SIT-LOCK® 3. See dedicated page.**

### Calculating transmissible torque $M_t$

$$M_t = \frac{P_{tot} - P_0}{\text{tg } \alpha + 2\mu} \cdot \mu \cdot \frac{d}{2}$$

where:

- $P_{tot}$  = total force given by the screws  $P_v \cdot N^\circ$  of screws
- $P_0$  = force required to deform rings without splits
- $\text{tg } \alpha$  = tangent to the angle of the rings.  $\text{tg } \alpha = 0.3$
- $\mu$  = coefficient of friction. Value found to be 0.12
- $d$  = shaft diameter

Table for determining the $P_v$ force depending on the $M_s$ value						
dg	Axial force $P_v$ in N			Tightening torque $M_s$ in Nm		
	8.8	10.9	12.9	8.8	10.9	12.9
<b>M2,5</b>	1.600	2.140	2.565	0,76	1,0	1,2
<b>M3</b>	2.210	3.110	3.730	1,3	1,9	2,2
<b>M4</b>	3.900	5.450	6.550	2,9	4,1	4,9
<b>M5</b>	6.350	8.950	10.700	6,0	8,5	10
<b>M6</b>	9.000	12.600	15.100	10	14	17
<b>M8</b>	16.500	23.200	27.900	25	35	41
<b>M10</b>	26.200	36.900	44.300	49	69	83
<b>M12</b>	38.300	54.000	64.500	86	120	145
<b>M14</b>	52.500	74.000	88.500	135	190	230
<b>M16</b>	73.000	102.000	123.000	210	295	355
<b>M18</b>	88.000	124.000	148.000	290	405	485
<b>M20</b>	114.000	160.000	192.000	410	580	690
<b>M22</b>	141.000	199.000	239.000	550	780	930
<b>M24</b>	164.000	230.000	276.000	710	1.000	1.200

### Installation

- tighten all screws to 50% of the screw tightening torque value  $M_s$  indicated in the table in a 'criss-cross' sequence;
- repeat to 100% of the  $M_s$  tightening torque indicated in the table;
- in continuous sequence, check that the tightening torque  $M_s$  has been achieved.

### Removal

Gradually loosen the clamping screws until the rings are fully removed.

# SIT-LOCK® 2 internal locking device - not self-centering

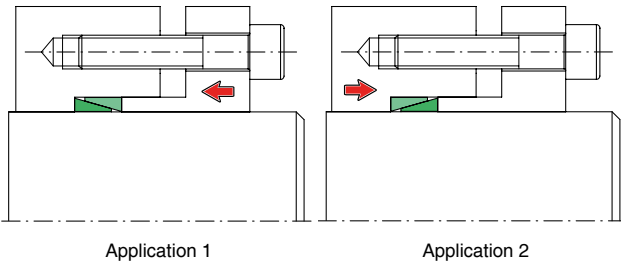

### Calculating the screw spacing l

For applications with hub fixed screws:

$$l = D + 12 + dg$$

For applications with shaft fixed screws:

$$l = d - 12 - dg$$

dg = clamping screw diameter

### Calculating flange thickness Sf

For applications with 8.8 screws:

$$Sf \geq dg \cdot 1,3$$

For applications with 10.9/12.9 screws:

$$Sf \geq dg \cdot 1,8$$

Dimensions [mm]			Pre-load force P <sub>0</sub> [kN]	Total force P <sub>tot</sub> [kN]	Permissible values when using the specified tolerances		Distance free of clamping screws (W) [mm]				Pressure	
d x D	H	H <sub>t</sub>			M <sub>t</sub> [Nm]	F <sub>ax</sub> [kN]	1	2	3	4	P <sub>w</sub> [N/mm <sup>2</sup> ]	P <sub>n</sub> [N/mm <sup>2</sup> ]
6 x 9	3,7	4,5	0	3,8	2,5	0,84	2,5	2,5	3	4	101	65
7 x 10	3,7	4,5	0	3,9	3	0,87	2,5	2,5	3	4	89	60
8 x 11	3,7	4,5	0	5,3	5	1,18	2,5	2,5	3	4	106	75
9 x 12	3,7	4,5	7,7	15,6	8	1,77	2,5	2,5	3	4	141	105
10 x 13	3,7	4,5	7,0	15,6	10	1,91	2,5	2,5	3	4	137	105
12 x 15	3,7	4,5	7,0	15,6	11	1,91	2,5	2,5	3	4	114	90
13 x 16	3,7	4,5	6,5	15,6	13	2,02	2,5	2,5	3	4	112	90
14 x 18	5,3	6,3	11,0	25,4	22	3,20	3,5	3,5	4,5	5,5	114	90
15 x 19	5,3	6,3	10,8	25,4	24	3,24	3,5	3,5	4,5	5,5	108	85
16 x 20	5,3	6,3	10,0	25,4	27	3,42	3,5	3,5	4,5	5,5	107	85
17 x 21	5,3	6,3	9,6	25,4	30	3,51	3,5	3,5	4,5	5,5	103	85
18 x 22	5,3	6,3	9,1	25,4	33	3,62	3,5	3,5	4,5	5,5	101	80
19 x 24	5,3	6,3	12,5	36	50	5,22	3,5	3,5	4,5	5,5	138	110
20 x 25	5,3	6,3	12,0	36	53	5,33	3,5	3,5	4,5	5,5	133	105
22 x 26	5,3	6,3	9,0	36	66	6,00	3,5	3,5	4,5	5,5	136	115
24 x 28	5,3	6,3	8,4	36	74	6,13	3,5	3,5	4,5	5,5	128	110
25 x 30	5,3	6,3	10,0	36	72	5,78	3,5	3,5	4,5	5,5	116	95
28 x 32	5,3	6,3	7,5	36	89	6,33	3,5	3,5	4,5	5,5	113	100
30 x 35	5,3	6,3	8,6	36	91	6,09	3,5	3,5	4,5	5,5	102	85
32 x 36	5,3	6,3	7,9	45	132	8,24	3,5	3,5	4,5	5,5	129	115
35 x 40	6	7	10	54	171	9,78	3,5	3,5	4,5	5,5	124	110
36 x 42	6	7	12	54	169	9,40	3,5	3,5	4,5	5,5	115	100
38 x 44	6	7	11	54	182	9,56	3,5	3,5	4,5	5,5	111	95
40 x 45	6,6	8	14	66	232	11,58	3,5	4,5	5,5	6,5	116	105
42 x 48	6,6	8	16	66	236	11,22	3,5	4,5	5,5	6,5	107	95
45 x 52	8,6	10	28	99	354	15,71	3,5	4,5	5,5	6,5	108	95
48 x 55	8,6	10	25	132	572	23,84	3,5	4,5	5,5	6,5	153	135
50 x 57	8,6	10	24	132	602	24,09	3,5	4,5	5,5	6,5	149	130
55 x 62	8,6	10	22	132	674	24,51	3,5	4,5	5,5	6,5	137	120
56 x 64	10,4	12	30	157	795	28,4	3,5	4,5	5,5	7	129	115
60 x 68	10,4	12	28	157	865	28,8	3,5	4,5	5,5	7	123	110
63 x 71	10,4	12	27	157	915	29,0	3,5	4,5	5,5	7	118	105
65 x 73	10,4	12	26	157	951	29,3	3,5	4,5	5,5	7	115	100
70 x 79	12,2	14	31	210	1.389	39,7	3,5	5	6,5	7,5	123	110
71 x 80	12,2	14	31	210	1.409	39,7	3,5	5	6,5	7,5	122	110
75 x 84	12,2	14	35	210	1.458	38,9	3,5	5	6,5	7,5	113	100
80 x 91	15	17	48	300	2.240	56,0	4	6	6,5	8	124	110
85 x 96	15	17	46	320	2.588	60,9	4	6	6,5	8	127	110
90 x 101	15	17	44	330	2.860	63,6	4	6	6,5	8	125	110
95 x 106	15	17	41	340	3.156	66,4	4	6	6,5	8	124	110
100 x 114	18,7	21	61	460	4.433	88,7	5	6	7	9	126	110
110 x 124	18,7	21	66	475	4.999	90,9	5	6	7	9	117	105
120 x 134	18,7	21	60	475	5.533	92,2	5	6	7	9	109	100
130 x 148	25,3	28	96	700	8.724	134,2	5	7	9	11	108	95
140 x 158	25,3	28	89	740	10.127	144,7	6	7	9	11	108	95
150 x 168	25,3	28	85	790	11.750	156,7	6	7	8	11	110	100
160 x 178	25,3	28	79	950	15.484	193,6	6	7	9	11	127	115
170 x 191	30	33	117	1.180	20.079	236	7	9	10	12	123	110
180 x 201	30	33	111	1.200	21.780	242	7	9	10	12	119	105
190 x 211	30	33	105	1.300	25.228	266	7	9	10	12	124	110
200 x 224	34,8	38	134	1.600	32.578	326	7	8	11	13	124	110
220 x 244	34,8	38	142	1.700	38.084	346	7	9	11	13	120	110
240 x 267	39,5	43	157	2.250	55.813	465	7	10	12	14	130	115

For dimensions not included in the table, please contact our Technical Department.  
Available with slit rings on request. Using SIT-LOCK® 2 with slit rings allows increased transmissible torque.

Internal - not self-centering

## SIT-LOCK® 10 - rigid joint

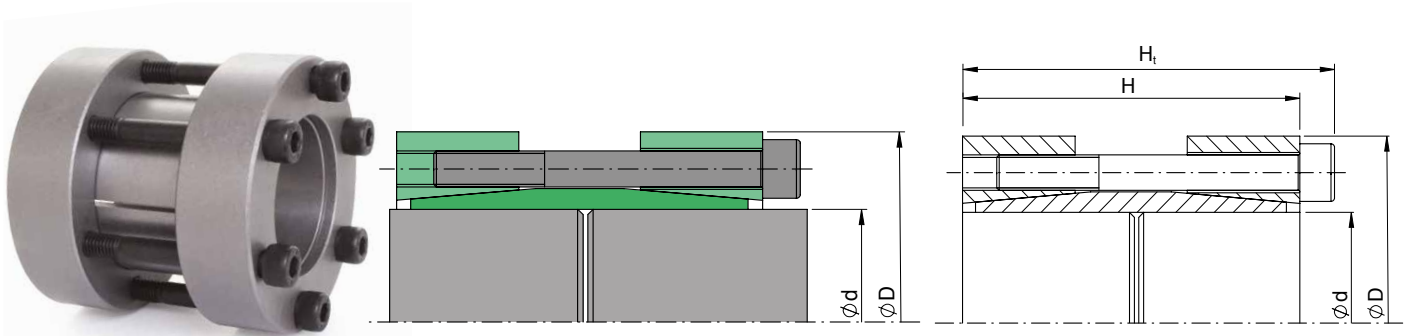

### Features

Composed of two tapered rings and a split inner ring. It is particularly suitable for clamping two shafts where medium-high torque transmission is required. The table shows performance data for the following tolerances:

shaft  $d_{h9}$

**Do not use molybdenum disulphide-based oils or greases that reduce the coefficient of friction  $\mu$ . The values in the table are calculated with  $\mu 0.12$ .**

### Installation with non-lubricated surfaces (dry)

The SIT-LOCK® 10 locking device is lubricated with oil before delivery to protect it from oxidation during storage. The values shown in the table have been calculated for applications with oiled contact surfaces. For dry installation, the values are:

$M_t, F_{ax} +25\%$

To get these value, the shaft and rigid joint inner ring contact surfaces must be cleaned with solvent. The shaft contact surfaces must also be completely dry.

### Surface finish

Normal surface finish is sufficient. The following values are recommended:

$R_a \leq 3,2 \mu m - R_t \leq 16 \mu m$

### Axial displacement

When tightening the screws there is a hub to shaft axial displacement. The axial displacement value depends on the locking device, shaft and hub seat tolerances.

### Installation

The coupling is supplied ready to assemble. Clean the shaft contact surfaces thoroughly and apply oil. Place the rigid joint between the two shafts to be connected, then:

- tighten two opposite screws until the coupling's inner ring surface makes contact with the shafts being joined;

- tighten all screws to 50% of the screw tightening torque value  $M_s$  indicated in the table in a 'criss-cross' sequence;
- repeat to 100% of the  $M_s$  tightening torque indicated in the table;
- in continuous sequence, check that the tightening torque  $M_s$  has been achieved. Installation is complete when all screws are tightened to the  $M_s$  tightening torque indicated in the table.

### Removal

- gradually loosen the clamping screws. This is usually enough to unlock the two tapered outer rings;
- if necessary, lightly tap the tapered rings with a hammer to facilitate removal.

### Reusing the rigid joint

For applications of considerable quantities, we can make a device with an inner ring that can couple two shafts of different diameters. See figure.

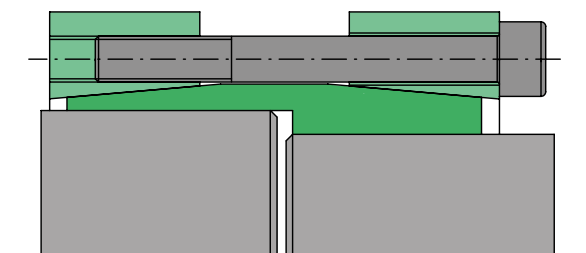

For quantities that do not justify mass production, we recommend making a split bushing to achieve the purpose of a serial joint. See figure.

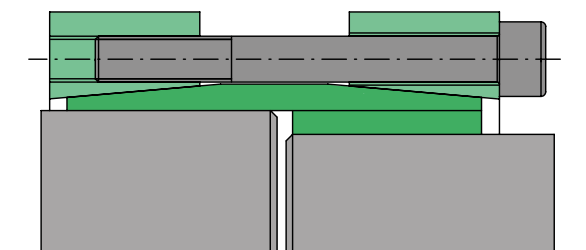

Recommended split bushing tolerances:  
inner diameter E7 - outer diameter e7

## SIT-LOCK® 10 - rigid joint

Dimensions [mm]			Clamping screws DIN 912 12.9			Values with tolerances for shaft h8/hub H8	
d x D	H	H <sub>t</sub>	Type	N°	M <sub>s</sub> [Nm]	M <sub>t</sub> [Nm]	F <sub>ax</sub> [kN]
15 x 45	50	56	M6	4	17	184	24,5
17 x 50	50	56	M6	4	17	208	24,5
18 x 50	50	56	M6	4	17	221	24,5
19 x 50	50	56	M6	4	17	233	24,5
20 x 50	50	56	M6	4	17	245	24,5
22 x 55	60	66	M6	6	17	404	36,7
24 x 55	60	66	M6	6	17	440	36,7
25 x 55	60	66	M6	6	17	459	36,7
28 x 60	60	66	M6	6	17	514	36,7
30 x 60	60	66	M6	6	17	551	36,7
32 x 63	60	66	M6	6	17	587	36,7
35 x 75	75	83	M8	4	41	791	45
38 x 75	75	83	M8	4	41	859	45
40 x 75	75	83	M8	4	41	904	45
42 x 78	75	83	M8	4	41	949	45
45 x 85	85	93	M8	6	41	1.526	68
48 x 90	85	93	M8	6	41	1.627	68
50 x 90	85	93	M8	6	41	1.695	68
55 x 94	85	93	M8	8	41	2.486	90
60 x 100	85	93	M8	8	41	2.712	90
65 x 105	85	93	M8	8	41	2.938	90
70 x 115	100	110	M10	6	83	3.766	108
75 x 120	100	110	M10	6	83	4.035	108
80 x 125	100	110	M10	8	83	5.740	144

M<sub>s</sub> Screw tightening torque      Nm  
M<sub>t</sub> Transmissible torque      Nm  
F<sub>ax</sub> Transmissible axial force      kN

**IMPORTANT:** The screw tightening torque M<sub>s</sub> can be reduced by 40% of the value indicated in the table. M<sub>t</sub>, F<sub>ax</sub>, P<sub>w</sub>, P<sub>n</sub> decrease proportionally.

For further information or in case of needs of diameters or dimensions different to those in the table, please contact our Technical Department.

## Application examples

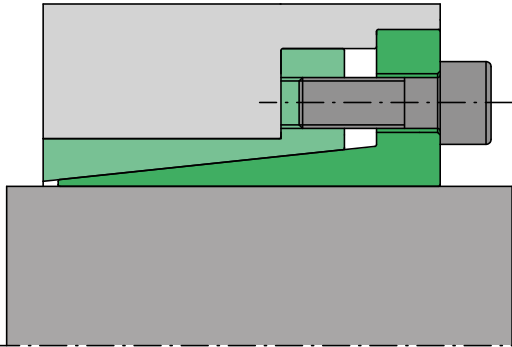

SIT-LOCK® 3 hub applications without spacer. Recommended for high rotation speeds.

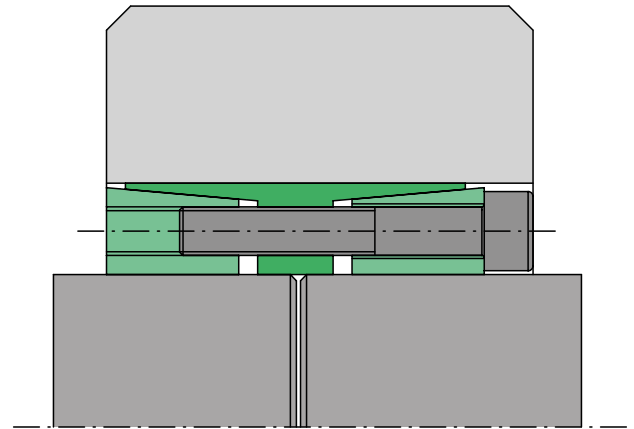

Locking two shafts and a hub using SIT-LOCK® 4. Only one locking device is used for locking 3 components.

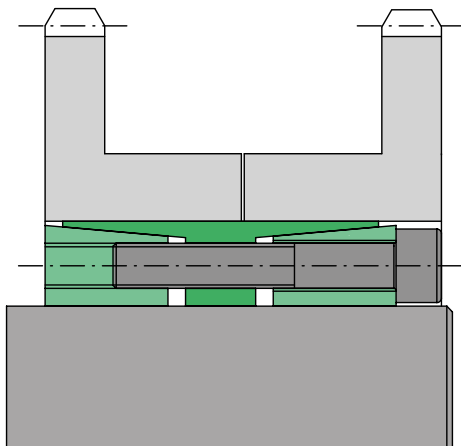

Simultaneously locking two sprockets using SIT-LOCK® 4.

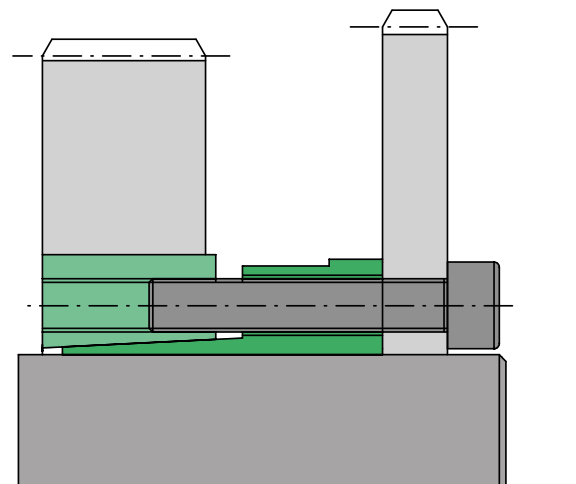

Joining a timing belt pulley and a brake disc with SIT-LOCK® 5A.

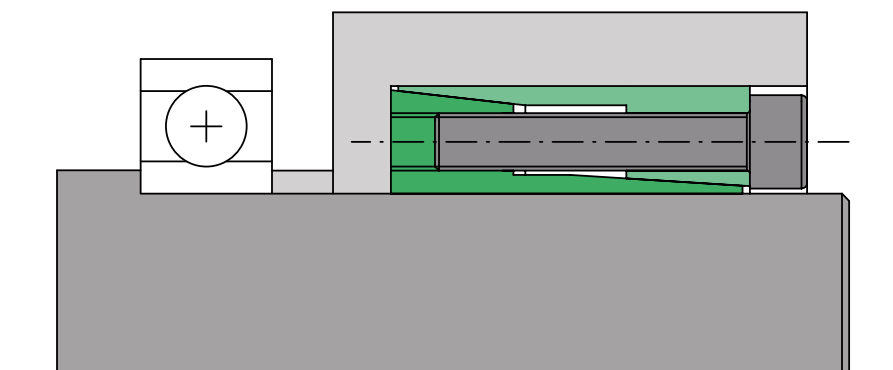

Locking a hub while also generating an axial force to axially lock a bearing.

## Customised versions available on request

### SIT-LOCK® 19

- Not self-centering
- High transmissible torques
- Available on request for shaft diameters of 70 to 320 mm
- No axial displacement when tightening the screws
- Quick installation and removal
- Outer diameter larger than SIT-LOCK® 4 - 4A

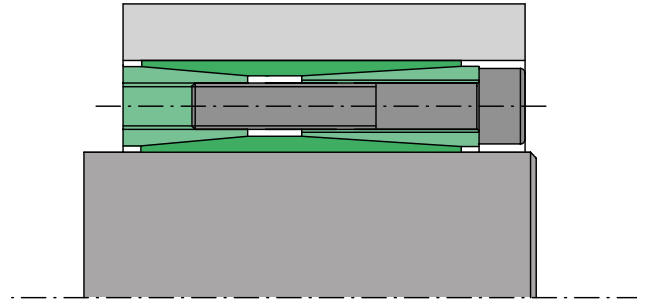

### SIT-LOCK® 21

- Self-centering
- Available on request for shaft diameters of 100 to 600 mm
- No axial displacement when tightening the screws
- High transmissible torques
- Easy to remove
- **Interchangeable with SIT-LOCK® 4 - 4A in terms of both dimensions and features**

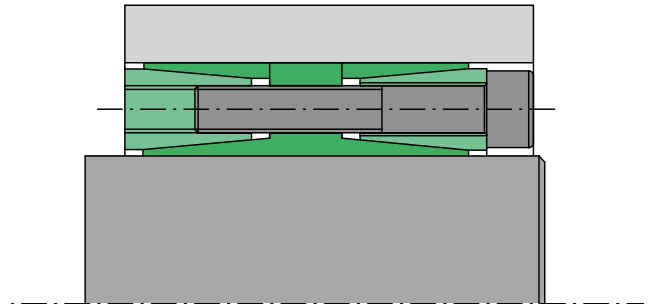

### SIT-LOCK® 15 speciale

- Excellent concentricity and perpendicularity
- Available on request for shaft diameters of 5 to 50 mm
- No axial displacement during assembly
- Low surface pressures
- Reduced axial dimensions
- Medium to high transmissible torques
- Easy to remove

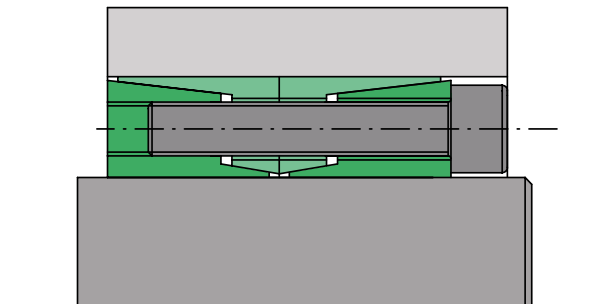

## SIT-LOCK® for use in corrosive environments

### SIT-LOCK® with electroless nickel plating

- All SIT-LOCK® locking devices are available with electroless nickel plating
- $M_t$ ,  $F_{ax}$ ,  $P_w$  and  $P_n$  values remain unchanged
- Excellent oxidation protection
- The screws are also supplied with electroless nickel plating
- Particularly recommended for applications in high humidity environments

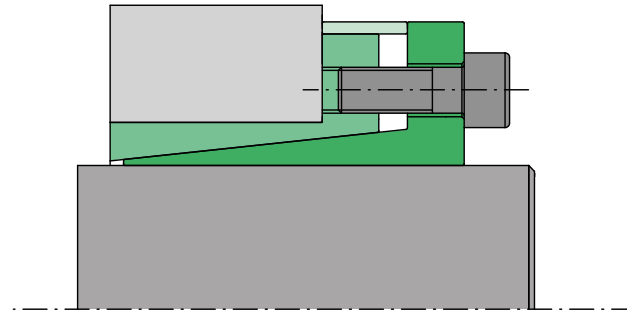

### SIT-LOCK® stainless steel

- Almost all SIT-LOCK® locking devices can be manufactured and supplied in stainless steel. The screws are also supplied in stainless steel
- The values  $M_t$ ,  $F_{ax}$ ,  $P_w$  and  $P_n$  differ from the values in the table
- Excellent, effective oxidation protection
- Highly recommended for applications in the food industry or aggressive environments





SHRINK DISC

A photograph of a shrink disc assembly, showing a metal flange with several bolts and a central ring component. The image is oriented vertically on the page.

**SHRINK DISC**

## SIT-LOCK® 11 - shrink disc

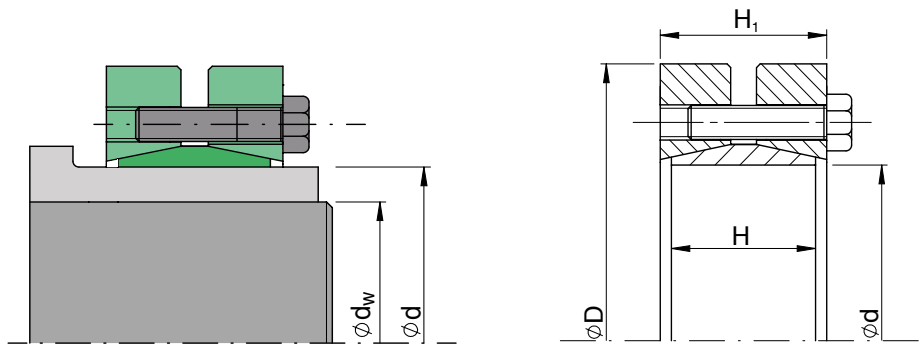

### Features

Composed of a split inner ring and two outer rings without slits. Supplied with DIN 931/933 10.9 screws except for SIT-LOCK® 11S 12.9 which is supplied with DIN 912 12.9 screws.

### SIT-LOCK® 11 versions

SIT-LOCK® 11	standard series (recommended version)
SIT-LOCK® 11 12.9	(version with DIN 912/933 12.9 screws)
SIT-LOCK® 11H	heavy duty series (for very high torques)
SIT-LOCK® 11L	light series (for low torques)

### Coupling tolerances

#### diameter d h8

#### diameter $d_w$ tolerances:

from 10 to 30 mm	H6 / j6
from 31 to 50 mm	H6 / h6
from 51 to 80 mm	H6 / g6
from 81 to 1000 mm	H7 / g6

**Do not use molybdenum disulphide-based oils or greases on diameter  $d_w$  surfaces. The values shown in the table are calculated for diameter surfaces  $d_w$  when dry only, not oiled. The diameter  $d$  surface can be oiled.**

### Surface finish

Normal surface finish is sufficient. The following values are recommended:

$$R_a \leq 3,2 \mu\text{m} - R_t \leq 16 \mu\text{m}$$

### Applications with bending moment

For applications where there is a bending moment  $M_f$  while a torque  $M_t$  is also transmitted, check that the  $M_{t \text{ tot}}$  value is less than the transmissible torque indicated in the table.

$$M_{t \text{ tot}} = \sqrt{M_t^2 + M_f^2}$$

Applying a bending moment 30% greater than the  $M_t$  value indicated in the table is not advised.

### Recommended materials for shaft $d_w$ and hub d

The pressure generated on diameter  $d$  generates a pressure  $P_w$  on the diameter  $d_w$ , which allows the transmission of the torque  $M_t$  indicated in the table. The pressure generated on the diameter  $d$  is distributed over the surface of the diameter  $d_w$  at an angle of approximately 16° - 20°. The pressure  $P_w$  can be determined using the following formula:

$$P_w = \frac{2 \cdot M_t}{\pi \cdot d_w^2 \cdot H \cdot \mu}$$

Shaft and hub materials with a  $\sigma_{0,2} \geq 360 \text{ N/mm}^2$  are recommended. For further information, please contact our Technical Department.

### Installation

The SIT-LOCK® 11 locking device is supplied ready to assemble. Clean the  $d_w$  shaft contact surfaces thoroughly. Mount the locking device on the hub  $d$  and insert the shaft into the bore  $d_w$ .

Screw tightening sequence:

- tighten 2 or 4 diametrically opposed screws until the hub surfaces  $d_w$  meet;
- gradually tighten the screws until the tightening torque  $M_s$  indicated in the table is reached;
- Installation is complete when all screws are tightened to the specified tightening torque  $M_s$ .

### Removal

Gradually loosen the clamping screws until the locking device is released.

### Reusing the locking device

When installing or removing the locking device, check all surfaces for signs of seizing or deformation. Reapply grease to the tapered surfaces of the inner ring and the two tapered bushings, the threads and the clamping screw underheads. Use grease with a coefficient of friction  $\mu$  of 0.04.

### Calculating the permissible axial force

$$F_{ax} = \frac{2 M_t}{d_w}$$

## SIT-LOCK® 11 - standard series

Dimensions [mm]					Transmissible torque	Clamping screws DIN 931/933 - 10.9		
d	D	d <sub>w</sub>	H	H <sub>1</sub>	M <sub>t</sub> [Nm]	Type	N°	M <sub>s</sub> [Nm]
14	38	11 12	7	11	32 53	M5	4	4
16	41	13 14	11	15	75 96	M5	5	4
24	50	19 20 21	14	19,5	170 210 250	M5	6	4
30	60	24 25 26	16	21,5	300 340 380	M5	7	4
36	72	28 30 31	18	23,5	440 570 630	M6	5	12
44	80	32 35 36	20	25,5	620 780 860	M6	7	12
50	90	38 40 42	22	27,5	940 1.160 1.380	M6	8	12
55	100	42 45 48	23	30,5	1.160 1.520 1.880	M6	8	12
62	110	48 50 52	23	30,5	1.750 2.000 2.250	M6	10	12
68	115	50 55 60	23	30,5	2.000 2.600 3.150	M6	10	12
75	138	55 60 65	25	32,5	2.400 3.200 3.950	M8	7	30
80	145	60 65 70	25	32,5	3.200 3.900 4.600	M8	7	30
85	155	65 70 75	30	39	4.800 6.100 7.400	M8	10	30
90	155	65 70 75	30	39	4.750 6.000 7.250	M8	10	30
95	170	70 75 80	34	44	7.000 7.650 9.150	M8	12	30
100	170	70 75 80	34	44	6.900 7.500 9.000	M8	12	30
110	185	75 80 85	39	50	7.200 9.000 10.800	M10	9	59
115	188	80 85 90	39	50	7.400 9.200 11.100	M10	10	59
120	215	80 85 90	42	54	10.600 13.300 14.500	M10	12	59
125	215	85 90 95	42	54	11.000 13.000 15.000	M10	12	59
130	215	90 95 100	42	54	11.300 13.300 15.400	M10	12	59
140	230	95 100 105	46	60,5	15.100 17.600 20.100	M12	10	100
155	265	105 110 115	50	64,5	22.000 25.000 28.000	M12	12	100

## Follow SIT-LOCK® 11 - standard series

Dimensions [mm]					Transmissible torque	Clamping screws DIN 931/933 - 10.9		
d	D	d <sub>w</sub>	H	H <sub>1</sub>	M <sub>t</sub> [Nm]	Type	N°	M <sub>s</sub> [Nm]
160	265	110	50	64,5	22.600	M12	12	100
		115			25.700			
		120			28.800			
165	290	115	56	71	31.000	M16	8	250
		120			35.000			
		125			39.000			
170	290	120	56	71	31.900	M16	8	250
		125			36.000			
		130			40.100			
175	300	125	56	71	36.000	M16	8	250
		130			41.000			
		135			45.000			
185	330	135	71	86	52.000	M16	10	250
		140			57.000			
		145			62.000			
195	350	140	71	86	65.000	M16	12	250
		150			76.000			
		155			81.500			
200	350	150	71	86	74.000	M16	12	250
		155			80.000			
		160			86.000			
220	370	160	88	104	95.000	M16	15	250
		165			102.000			
		170			110.000			
240	405	170	92	109	120.000	M20	12	490
		180			138.000			
		190			156.000			
260	430	190	103	120	164.000	M20	14	490
		200			184.000			
		210			205.000			
280	460	210	114	134	217.000	M20	16	490
		220			244.000			
		230			270.000			
300	485	230	122	142	275.000	M20	18	490
		240			295.000			
		245			315.000			
320	520	240	122	142	312.000	M20	20	490
		250			340.000			
		260			374.000			
340	570	250	134	156	390.000	M20	24	490
		260			422.500			
		270			460.000			
350	580	270	140	162	442.000	M20	24	490
		280			480.000			
		285			500.000			
360	590	280	140	162	463.000	M20	24	490
		290			502.000			
		295			522.000			
380	645	290	144	168	567.000	M24	20	840
		300			610.000			
		310			658.000			
390	660	300	144	168	624.000	M24	21	840
		310			671.000			
		320			718.000			
400	680	315	144	168	670.000	M24	21	840
		320			695.000			
		330			744.000			
420	690	330	164	188	780.000	M24	24	840
		340			840.000			
		350			900.000			
440	750	340	177	202	806.000	M24	24	840
		350			860.000			
		360			917.000			
460	770	360	177	202	1.000.000	M24	28	840
		370			1.070.000			
		380			1.140.000			
480	800	380	188	213	1.170.000	M24	30	840
		390			1.240.000			
		400			1.310.000			

## SIT-LOCK® 11 12.9 - version with DIN 912/933 12.9 screws

Dimensions [mm]					Transmissible torque $M_t$ [Nm]	Clamping screws DIN 912/931/933 - 12.9		
d	D	d <sub>w</sub>	H	H <sub>1</sub>		Type	N°	M <sub>s</sub> [Nm]
24	50	19 20 21	14	19,5	245 285 325	M5	6	4
30	60	24 25 26	16	21,5	375 415 465	M5	7	4
36	72	28 30 31	18	23,5	910 1.000 1.100	M6	5	14
44	80	32 35 36	20	25,5	1.250 1.600 1.680	M6	7	14
50	90	38 40 42	22	27,5	1.830 2.070 2.350	M6	8	14
55	100	42 45 48	23	30,5	2.020 2.400 2.850	M6	8	14
62	110	48 50 52	23	30,5	3.030 3.190 3.540	M6	10	14
68	115	50 55 60	23	30,5	2.700 3.500 4.420	M6	10	14
75	138	55 60 65	25	32,5	4.100 5.120 6.290	M8	7	35
80	145	60 65 70	25	32,5	4.620 5.690 6.870	M8	7	35
90	155	65 70 75	30	39	6.950 8.350 9.890	M8	10	35
100	170	70 75 80	34	44	8.630 10.250 12.000	M8	12	35
110	185	75 80 85	39	50	11.060 12.940 14.300	M10	9	72
125	215	85 90 95	42	54	16.200 18.700 21.450	M10	12	72
140	230	95 100 105	46	60,5	22.400 25.420 28.680	M12	10	120
155	265	105 110 115	50	64,5	30.120 33.750 37.550	M12	12	120
165	290	115 120 125	56	71	44.500 48.450 53.450	M16	8	300
175	300	125 130 135	56	71	49.200 54.100 59.200	M16	8	300
185	330	135 140 145	71	86	68.300 74.600 81.150	M16	10	300
195	350	140 150 155	71	86	86.650 100.200 107.100	M16	12	300
200	350	150 155 160	71	86	95.750 102.550 109.500	M16	12	300
220	370	160 165 170	88	104	124.400 134.500 144.980	M16	15	300
240	405	170 180 190	92	109	157.200 177.200 200.850	M20	12	580

## Follow SIT-LOCK® 11 12.9 - version with DIN 912/933 12.9 screws

Dimensions [mm]					Transmissible torque	Clamping screws DIN 912/931/933 - 12.9		
d	D	d <sub>w</sub>	H	H <sub>t</sub>	M <sub>t</sub> [Nm]	Type	N°	M <sub>s</sub> [Nm]
260	430	190	103	120	211.650	M20	14	580
		200			238.300			
		210			266.600			
280	460	210	114	134	278.800	M20	16	580
		220			303.800			
		230			329.100			
300	485	230	122	142	349.800	M20	18	580
		240			378.000			
		245			394.500			
320	520	240	122	142	404.500	M20	20	580
		250			430.900			
		260			463.300			
340	570	250	134	156	499.600	M20	24	580
		260			537.300			
		270			575.650			
350	580	270	140	162	550.900	M20	24	580
		280			589.400			
		285			612.800			
360	590	280	140	162	573.200	M20	24	580
		290			612.000			
		295			635.700			
380	645	290	144	168	715.000	M24	20	1000
		300			760.800			
		310			807.200			
390	660	300	144	168	782.100	M24	21	1000
		310			830.200			
		320			874.000			
400	680	315	144	168	829.000	M24	21	1000
		320			853.000			
		330			903.000			
420	690	330	164	188	987.000	M24	24	1000
		340			1.043.200			
		350			1.100.700			
440	750	340	177	202	1.002.800	M24	24	1000
		350			1.060.400			
		360			1.119.000			
460	770	360	177	202	1.261.000	M24	28	1000
		370			1.328.000			
		380			1.395.300			
480	800	380	188	213	1.434.000	M24	30	1000
		390			1.506.300			
		400			1.580.000			

## SIT-LOCK® 11H - heavy duty series

Dimensions [mm]					Transmissible torque	Clamping screws DIN 931/933 - 10.9		
d	D	d <sub>w</sub>	H	H <sub>1</sub>	M <sub>t</sub> [Nm]	Type	N°	M <sub>s</sub> [Nm]
125	215	85	55	65	15.000	M12	10	100
		90			17.500			
		95			20.000			
140	230	95	60	74	20.600	M12	12	100
		100			23.500			
		105			26.500			
155	265	105	66	80	28.600	M12	15	100
		110			32.500			
		115			36.400			
165	290	115	72	88	41.000	M16	10	250
		120			46.000			
		125			50.700			
175	300	125	72	88	47.000	M16	10	250
		130			52.000			
		135			57.000			
185	330	135	92	112	72.000	M16	14	250
		140			78.000			
		145			86.000			
195	350	140	92	112	75.000	M16	14	250
		150			88.000			
		155			96.000			
200	350	145	92	112	85.000	M16	15	250
		150			92.500			
		155			100.000			
220	370	160	114	134	127.000	M16	20	250
		165			136.000			
		170			146.500			
240	405	170	120	144	155.000	M20	15	490
		180			176.000			
		190			198.000			
260	430	190	136	160	213.000	M20	18	490
		200			240.000			
		210			268.000			
280	460	210	148	172	285.000	M20	21	490
		220			320.000			
		230			355.000			
300	485	230	152	176	341.000	M20	22	490
		240			376.000			
		245			394.000			
320	520	240	160	184	378.500	M20	24	490
		250			415.000			
		260			451.000			
340	570	250	176	200	489.500	M24	21	840
		260			530.000			
		270			578.000			
350	580	270	176	200	556.000	M24	21	840
		280			604.000			
		285			629.000			
360	590	280	180	204	612.000	M24	22	840
		290			663.000			
		295			689.000			
380	645	290	180	204	618.000	M24	22	840
		300			668.000			
		310			719.000			
390	660	300	188	212	708.000	M24	24	840
		310			762.000			
		320			814.500			
400	680	315	188	212	765.000	M24	24	840
		320			788.000			
		330			845.000			
420	690	330	214	238	999.000	M24	30	840
		340			1.068.000			
		350			1.140.000			
440	750	340	224	252	1.058.000	M27	24	1.250
		350			1.130.000			
		360			1.204.000			
460	770	360	224	252	1.320.000	M27	28	1.250
		370			1.420.000			
		380			1.500.000			

Shrink discs

## SIT-LOCK® 11L - light series

Dimensions [mm]					Transmissible torque	Clamping screws DIN 931/933 - 10.9		
d	D	d <sub>w</sub>	H	H <sub>1</sub>	M <sub>t</sub> [Nm]	Type	N°	M <sub>s</sub> [Nm]
125	185	95	39	51	10.550	M10	8	59
		100			12.100			
		105			13.800			
140	220	110	39	51	14.800	M10	9	59
		120			18.640			
		125			20.500			
155	245	130	39	51	24.000	M10	11	59
		135			26.400			
		140			29.000			
165	260	135	46	62	32.000	M12	10	100
		140			35.200			
		145			38.500			
175	275	145	46	62	39.000	M12	11	100
		150			42.400			
		155			46.000			
185	295	155	46	62	46.600	M12	12	100
		160			50.300			
		165			54.000			
195	315	165	56	72	63.000	M12	15	100
		170			67.700			
		175			72.500			
200	330	175	56	72	74.000	M12	16	100
		180			79.500			
		185			84.500			
220	345	180	66	84	82.800	M16	10	250
		190			93.500			
		200			105.000			
240	370	200	66	84	113.000	M16	12	250
		210			127.500			
		215			134.500			
260	395	220	72	92	149.000	M16	14	250
		230			165.000			
		235			173.000			
280	425	230	84	104	171.000	M16	16	250
		240			189.000			
		250			208.000			
300	460	250	84	104	215.000	M16	18	250
		260			234.000			
		270			255.000			
320	495	270	84	106	260.000	M16	20	250
		280			284.000			
		290			306.000			
340	535	290	84	106	300.000	M16	21	250
		300			324.400			
		305			337.000			
350	545	300	100	122	372.000	M20	16	490
		305			385.000			
		310			400.000			
360	555	300	100	122	360.000	M20	16	490
		310			388.000			
		320			415.000			
380	585	320	112	136	435.000	M20	18	490
		325			451.000			
		330			467.000			
390	595	330	112	136	505.000	M20	20	490
		340			540.000			
		350			577.000			
400	615	340	112	136	550.000	M20	21	490
		350			587.000			
		360			626.000			
420	630	350	120	144	578.000	M20	22	490
		360			617.000			
		370			655.000			
440	660	370	120	144	677.000	M20	24	490
		380			719.000			
		390			762.000			
460	685	390	132	158	840.000	M20	28	490
		400			890.000			
		410			935.000			

## SIT-LOCK® 14 - shrink disc

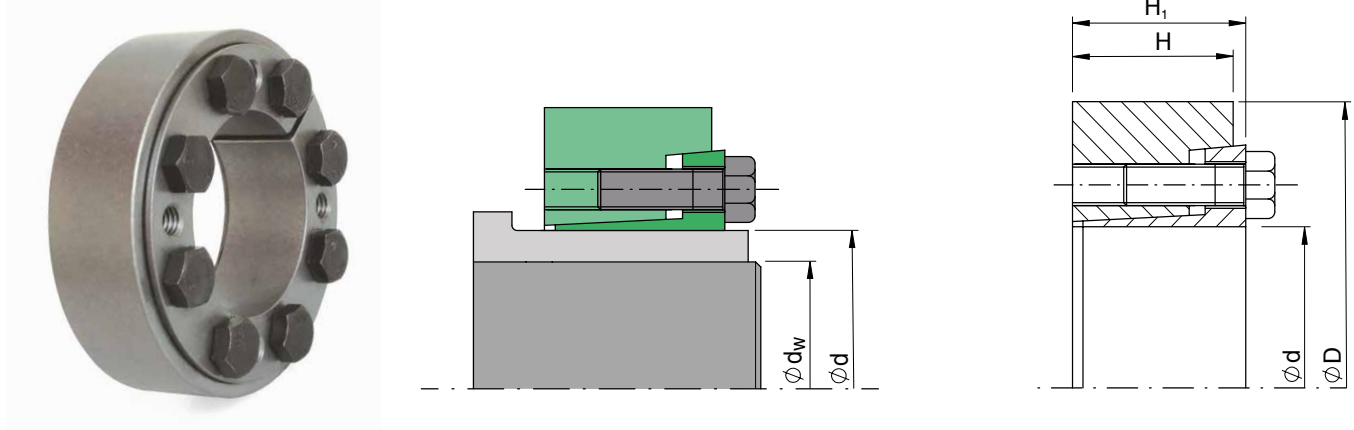

### Features

Composed of an inner ring and an outer ring. Comes with DIN 931/933 10.9 or 12.9 screws depending on the model.

### SIT-LOCK® 14 versions

SIT-LOCK® 1422-1481	standard series (recommended version)
SIT-LOCK® 1423-1483	heavyweight series for high torque
SIT-LOCK® 1421	lightweight series for low torque

### Coupling tolerances

#### diameter d f7

#### diameter d<sub>w</sub> tolerances

≤ 160 mm	H7 / h6
≥ 160 mm	H7 / g6

**Do not use molybdenum disulphide-based oils or greases on diameter d<sub>w</sub> surfaces. The values shown in the table are calculated for diameter surfaces d<sub>w</sub> when dry only, not oiled. The diameter d surface can be oiled.**

### Surface finish

Normal surface finish is sufficient. The following values are recommended:

$$R_a \leq 3,2 \mu\text{m} - R_t \leq 16 \mu\text{m}$$

### Applications with bending moment

For applications where there is a bending moment  $M_f$  while a torque  $M_t$  is also transmitted, check that the  $M_{t \text{ tot}}$  value is less than the transmissible torque indicated in the table.

$$M_{t \text{ tot}} = \sqrt{M_t^2 + M_f^2}$$

Applying a bending moment 30% greater than the  $M_t$  value indicated in the table is not advised.

### Recommended materials for shaft d<sub>w</sub> and hub d

The pressure generated on diameter d generates a pressure  $P_w$  on the diameter d<sub>w</sub>, which allows the torque transmission  $M_t$  indicated in the table. The pressure generated on the diameter d is distributed over the surface of the diameter d<sub>w</sub> at an angle of approximately 16°- 20°. The pressure  $P_w$  can be determined using the following formula:

$$P_w = \frac{2 \cdot M_t}{\pi \cdot d_w^2 \cdot H \cdot \mu}$$

Shaft and hub materials with a  $\sigma_{0,2} \geq 360 \text{ N/mm}^2$  are recommended. For applications subject to bending moments, using tempered shafts is recommended, such as steel 42 CrMo4. For further information or confirmation, please contact our Technical Department.

### Special version of the SIT-LOCK® 14 available on request

A special version of the SIT-LOCK® 14 is available on request, which can be fitted without the need for a torque wrench. It is important that the flat surface of the inner ring aligns with the flat surface of the outer ring when installation is complete.

See figure:

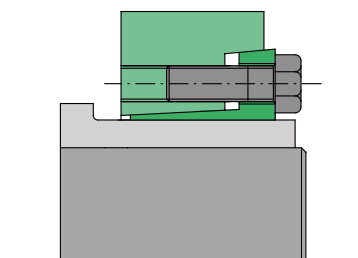

SIT-LOCK® 14 not assembled

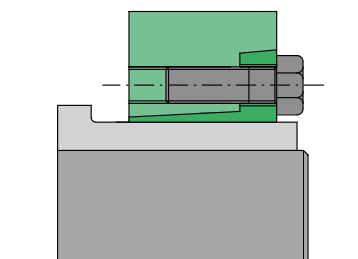

SIT-LOCK® 14 assembled

When the two components' surfaces are aligned, installation is complete and the values indicated in the table will have been achieved.

Since the clamping screws are not typically tightened using a torque wrench, the values indicated in the table are often not reached. In these cases, slippage could occur resulting in economic damages.

*The SIT-LOCK® 14 internal locking device should be considered the most effective development in the field of friction shaft-hub couplings as it can be assembled without using a torque wrench and, thanks to the alignment, still guarantees simple, functional installation.*

### Installation

The SIT-LOCK® 14 locking device is supplied ready to assemble. Clean the  $d_w$  shaft contact surfaces thoroughly. The contact surface of diameter  $d_w$  must be dry, without any traces of oil. The transmissible torque  $M_t$  is calculated with a coefficient of friction  $\mu$  equal to 0.15. Mount the locking device on the hub  $d$  and insert the shaft into the bore  $d_w$ .

Caution: Do not tighten the screws before placing the locking device on the hub.

Clean the diameter  $d$  contact surface and apply a light film of oil to facilitate the locking device's positioning.

### Installation without torque wrench

- tighten 2 or 4 diametrically opposed screws until the diameter  $d_w$  contact surfaces are locked
- gradually tighten the screws clockwise until the lateral surfaces of the inner and outer ring are completely aligned
- Installation is complete once alignment has been achieved

### Installation with torque wrench

- tighten 2 or 4 diametrically opposed screws until the diameter  $d_w$  contact surfaces are locked. This does not require a torque wrench;
- tighten the screws clockwise, in continuous sequence, to 50% of the  $M_s$  tightening torque indicated in the table;
- tighten the screws clockwise, in continuous sequence, to 100% of the  $M_s$  tightening torque indicated in the table;
- continue tightening the screws clockwise, in continuous sequence, to 100% of the  $M_s$  tightening torque indicated in the table.

### Removal

Loosen the screws in a continuous sequence until the locking device is fully removed. If the locking device does not disassemble after all screws have been loosened, insert the clamping screws into the removal threads on the inner ring. Tighten the screws in a 'criss-cross' sequence until the locking device is released.

### Reusing the locking device

When installing or removing the locking device, check all surfaces for signs of seizing or deformation. Reapply grease to the tapered surfaces of the inner ring and outer ring, the threads and the clamping screw underheads. Use grease with a coefficient of friction  $\mu$  of 0.04. For further information, please contact our Technical Department.

### High speed applications

For applications that require greater balance, SIT-LOCK® 14 is recommended rather than SIT-LOCK® 11, as incorrect parallelism may create issues at high rotation speeds.

**SIT-LOCK® 1422 - 1481 shrink disc**

Dimensions [mm]					SIT-LOCK® 1422		SIT-LOCK® 1481		Clamping screws DIN 933/931 10.9 (1422) - 12.9 (1481)
d	D	d <sub>w</sub>	H	H <sub>1</sub>	M <sub>t</sub> [Nm]	M <sub>s</sub> [Nm]	M <sub>t</sub> [Nm]	M <sub>s</sub> [Nm]	
12	35	9	10	11	20	12	-	-	M6
		10			40		-		
14	38	11	10	11	30	12	-	-	M6
		12			50		-		
16	41	13	13,5	15	70	12	-	-	M6
		14			90		-		
18	44	15	13,5	15	80	12	-	-	M6
		16			110		-		
20	47	17	13,5	15	150	12	-	-	M6
		18			180		-		
24	50	19	16	18	160	12	-	-	M6
		20			210		-		
		22			280		-		
30	60	24	18	20	270	12	-	-	M6
		25			320		-		
		26			360		-		
36	72	27	20	22	440	30	-	-	M8
		30			610		-		
		33			820		-		
44	80	34	22	24	690	30	-	-	M8
		35			770		-		
		37			920		-		
50	90	38	23,5	26	1.110	30	1.500	35	M8
		40			1.290		1.700		
		42			1.510		1.900		
55	100	42	26	29	1.230	30	1.600	35	M8
		45			1.530		2.000		
		48			1.860		2.400		
62	110	48	26	29	1.670	30	2.200	35	M8
		50			1.890		2.400		
		52			2.120		2.700		
68	115	50	26	29	1.870	30	2.400	35	M8
		55			2.450		3.000		
		60			3.120		3.800		
75	138	55	27	31	2.330	59	3.700	70	M10
		60			3.020		4.700		
		65			3.810		5.800		
80	145	60	27	31	3.190	59	4.200	70	M10
		65			4.060		5.200		
		70			4.910		6.300		
90	155	65	34	38	5.400	59	5.900	70	M10
		70			6.500		7.100		
		75			7.800		8.500		
100	170	70	39	43	6.000	59	7.400	70	M10
		75			7.200		8.900		
		80			8.500		10.400		
110	185	80	43,5	49	10.000	100	12.600	121	M10
		85			11.700		14.600		
		90			13.600		16.900		
120	197	85	46,5	53	11.900	100	13.600	121	M12
		90			13.800		15.700		
		95			15.900		18.000		
125	215	90	46,5	53	14.400	100	16.400	121	M12
		95			16.500		18.800		
		100			18.700		21.300		
130	215	90	46,5	53	14.100	100	16.000	121	M12
		95			16.100		18.400		
		100			18.300		20.800		
135	230	95	49,5	58	18.100	160	20.300	195	M14
		100			20.600		23.000		
		110			26.000		28.900		
140	230	100	49,5	58	19.600	160	23.000	195	M14
		105			22.100		25.800		
		115			27.600		32.100		
155	263	110	53,5	62	26.500	160	31.100	195	M14
		115			29.500		34.500		
		125			36.100		42.000		
165	290	120	58	68	37.300	250	44.000	300	M16
		125			41.200		48.500		
		135			49.600		58.100		
175	300	130	58	68	45.000	250	54.000	300	M16
		135			49.000		59.000		
		145			58.000		70.000		

## Follow SIT-LOCK® 1422 - 1481 shrink disc

Dimensions [mm]					SIT-LOCK® 1422		SIT-LOCK® 1481		Clamping screws DIN 933/931 10.9 (1422) - 12.9 (1481)
d	D	d <sub>w</sub>	H	H <sub>1</sub>	M <sub>t</sub> [Nm]	M <sub>s</sub> [Nm]	M <sub>t</sub> [Nm]	M <sub>s</sub> [Nm]	
185	320	140	75	85	64.000	250	81.000	300	M16
		145			70.000		88.000		
		155			82.000		102.000		
200	340	150	75	85	81.000	250	96.000	300	M16
		155			87.000		103.000		
		165			100.000		119.000		
220	370	160	91	103	103.000	490	129.000	570	M20
		170			119.000		149.000		
		180			136.000		169.000		
240	405	170	94	107	122.000	490	151.000	570	M20
		180			140.000		172.000		
		200			179.000		218.000		
260	430	190	105	119	163.000	490	212.000	570	M20
		200			184.000		238.000		
		220			231.000		297.000		
280	460	210	116	132	215.000	490	279.000	570	M20
		220			240.000		311.000		
		240			295.000		379.000		
300	485	220	124	140	270.000	840	332.000	980	M24
		230			300.000		367.000		
		250			363.000		443.000		
320	520	240	124	140	301.000	840	404.000	980	M24
		250			332.000		444.000		
		270			398.000		528.000		
340	570	250	137	155	390.000	840	488.000	980	M24
		260			427.000		533.000		
		280			506.000		630.000		
350	580	270	142	162	493.000	840	616.000	980	M24
		280			535.000		669.000		
		290			580.000		725.000		
360	590	270	142	162	496.000	840	625.000	980	M24
		280			539.000		677.000		
		300			631.000		790.000		
380	640	290	146	166	585.000	1.250	725.000	1.450	M27
		300			632.000		783.000		
		310			681.000		844.000		
390	650	290	146	166	640.000	1.250	781.000	1.450	M27
		300			691.000		842.000		
		320			799.000		971.000		
420	670	320	166	186	742.000	1.250	969.000	1.450	M27
		330			797.000		1.038.000		
		350			912.000		1.183.000		
440	720	340	174	194	945.000	1.250	1.212.000	1.450	M27
		350			1.009.000		1.292.000		
		370			1.143.000		1.460.000		
460	770	360	174	194	1.104.000	1.250	1.393.000	1.450	M27
		370			1.174.000		1.479.000		
		390			1.320.000		1.660.000		
480	800	380	191	213	1.300.000	1.640	1.657.000	1.970	M30
		390			1.378.000		1.754.000		
		410			1.541.000		1.956.000		
500	850	400	191	213	1.496.000	1.640	1.887.000	1.970	M30
		410			1.581.000		1.992.000		
		430			1.759.000		2.211.000		
530	910	430	216	238	1.930.000	1.640	2.397.000	1.970	M30
		440			2.031.000		2.521.000		
		460			2.243.000		2.778.000		
560	940	450	216	238	2.097.000	1.640	2.545.000	1.970	M30
		460			2.201.000		2.671.000		
		480			2.420.000		2.930.000		
590	960	470	235	260	2.593.000	1.640	2.969.000	1.970	M30
		480			2.715.000		3.108.000		
		500			2.970.000		3.397.000		
620	980	500	261	286	2.940.000	1.640	3.602.000	1.970	M30
		520			3.169.000		3.708.000		
		540			3.447.000		4.028.000		
660	1020	530	270	292	3.329.500	2.210	4.035.000	2.400	M33
		550			3.615.000		4.374.000		
		570			3.912.000		4.727.000		

### SIT-LOCK® 1423 - 1483 shrink disc

Dimensions [mm]					SIT-LOCK® 1423		SIT-LOCK® 1483		Clamping screws DIN 931 10.9 (1423) - 12.9 (1483)
d	D	d <sub>w</sub>	H	H <sub>1</sub>	M <sub>t</sub> [Nm]	M <sub>s</sub> [Nm]	M <sub>t</sub> [Nm]	M <sub>s</sub> [Nm]	
140	230	100	64	74	26.000	250	30.000	300	M16
		105			30.000		34.000		
		115			37.000		42.000		
155	263	110	70	80	36.000	250	45.000	300	M16
		115			40.000		49.000		
		125			48.000		60.000		
165	290	120	77	88	50.000	250	63.000	300	M16
		125			55.000		69.000		
		135			66.000		83.000		
175	300	130	77	88	61.000	250	73.000	300	M16
		135			67.000		80.000		
		145			79.000		94.000		
185	320	140	100	112	89.000	490	106.000	570	M20
		145			96.000		115.000		
		155			113.000		134.000		
200	340	150	100	112	104.000	490	126.000	570	M20
		155			113.000		136.000		
		165			130.000		157.000		
220	370	160	121	134	127.000	490	162.000	570	M20
		165			137.000		174.000		
		180			169.000		213.000		
240	405	170	130	144	157.000	490	206.000	570	M20
		180			180.000		235.000		
		200			230.000		298.000		
260	430	190	144	160	230.000	490	285.000	570	M20
		200			260.000		321.000		
		220			325.000		399.000		
280	460	210	156	172	306.000	840	361.000	980	M24
		220			342.000		401.000		
		240			418.000		489.000		
300	485	230	158	176	360.000	840	461.000	980	M24
		240			398.000		508.000		
		250			437.000		556.000		
320	520	240	166	184	430.000	840	512.000	980	M24
		250			473.000		562.000		
		270			565.000		670.000		
340	570	250	186	206	551.000	1250	661.000	1.450	M27
		260			603.000		722.000		
		280			714.000		852.000		
360	590	270	188	210	671.000	1250	763.000	1.450	M27
		280			729.000		828.000		
		300			852.000		966.000		
390	650	290	196	220	850.000	1250	978.000	1.450	M27
		300			917.000		1.054.000		
		320			1.061.000		1.217.000		
420	690	320	221	246	1.007.000	1250	1.297.000	1.450	M27
		330			1.080.000		1.389.000		
		350			1.235.000		1.582.000		
440	750	340	233	258	1.218.000	1640	1.583.000	1.970	M30
		350			1.301.000		1.687.000		
		370			1.475.000		1.907.000		
460	770	360	233	258	1.402.000	1640	1.734.000	1.970	M30
		370			1.491.000		1.841.000		
		390			1.678.000		2.067.000		
480	800	380	270	298	1.707.000	1640	2.076.000	1.970	M30
		390			1.809.000		2.198.000		
		410			2.023.000		2.452.000		
500	850	400	270	300	1.993.000	1640	2.529.000	1.970	M30
		410			2.106.000		2.669.000		
		430			2.342.000		2.962.000		
530	890	430	306	338	2.549.000	2210	3.093.000	2.650	M33
		440			2.683.000		3.252.000		
		460			2.962.000		3.584.000		
560	940	450	306	338	2.837.000	2210	3.439.000	2.650	M33
		460			2.978.000		3.607.000		
		480			3.272.000		3.956.000		

Shrink discs

**SIT-LOCK® 1421 shrink disc**

Dimensions [mm]					Transmissible torque	Clamping screws DIN 933 - 10.9	
d	D	d <sub>w</sub>	H	H <sub>1</sub>	M <sub>t</sub> [Nm]	Type	M <sub>s</sub> [Nm]
140	215	110	38	46	16.000	M12	100
		120			20.000		
		130			25.000		
155 160	245	130	38	46	26.000	M12	100
		135			28.000		
		140			31.000		
165 170	263	135	43	53	29.000	M14	160
		140			32.000		
		145			35.000		
175 180	275	145	43	53	36.000	M14	160
		150			39.000		
		155			42.000		
185 190	290	155	51	62	50.000	M14	160
		160			54.000		
		165			58.000		
195 200	320	165	51	62	68.000	M14	160
		170			73.000		
		180			83.000		
220	340	180	55	70	80.000	M16	240
		190			91.000		
		200			103.000		
240	370	200	55	70	103.000	M16	240
		210			115.000		
		220			128.000		
260	405	220	55	70	132.000	M16	240
		230			146.000		
		240			161.000		
280	430	230	65	80	160.000	M20	470
		240			177.000		
		250			194.000		
300	460	250	65	80	191.000	M20	470
		260			209.000		
		270			228.000		
320	485	270	77	92	243.000	M20	470
		280			265.000		
		290			288.000		
340	520	280	77	92	274.000	M20	470
		290			297.000		
		300			322.000		
360	570	300	89	105	356.000	M20	470
		310			384.000		
		330			443.000		
390	590	330	89	105	438.000	M20	470
		340			469.000		
		350			501.000		
420	630	350	120	140	624.000	M24	820
		360			665.000		
		370			709.000		
440	660	370	132	152	778.000	M24	820
		380			826.000		
		390			877.000		
460	690	390	132	152	852.000	M24	820
		400			903.000		
		410			955.000		
480	720	410	152	174	1.086.000	M24	820
		420			1.147.000		
		430			1.210.000		
500	745	420	152	174	1.137.000	M24	820
		430			1.200.000		
		450			1.331.000		
530	790	450	162	186	1.376.000	M27	1.210
		460			1.446.000		
		480			1.592.000		
560	830	480	162	187	1.578.000	M27	1.210
		490			1.653.000		
		510			1.809.000		
590	880	510	172	197	1.873.000	M27	1.210
		520			1.957.000		
		540			2.131.000		
620	930	540	172	198	2.097.000	M27	1.210
		550			2.186.000		
		570			2.368.000		
660	990	570	182	209	2.426.000	M30	1.640
		580			2.522.000		
		610			2.823.000		
700	1040	610	182	210	2.772.000	M30	1.640
		620			2.874.000		
		640			3.084.000		
750	1100	640	192	222	3.104.000	M30	1.640
		650			3.214.000		
		680			3.555.000		
800	1150	680	192	224	3.443.000	M30	1.640
		700			3.673.000		
		730			4.033.000		

## Application examples

Simultaneously locking one gear and two shafts using SIT-LOCK® 14.

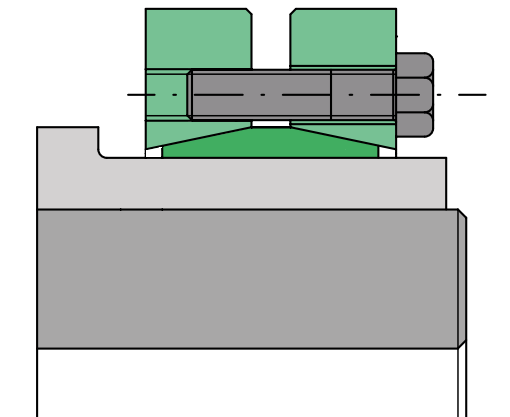
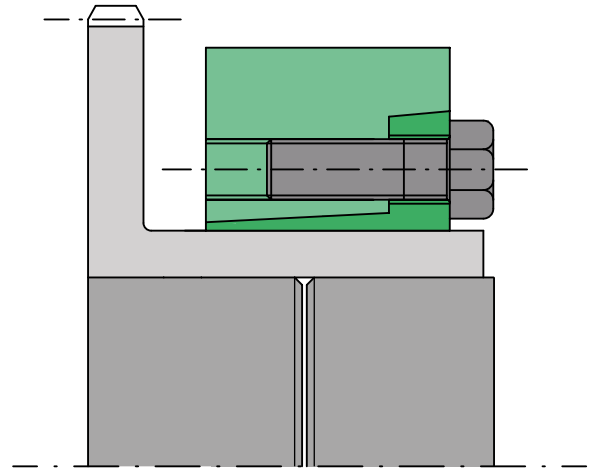

Locking a hub with its shaft using SIT-LOCK® 11. There is a bore in the shaft. For applications with shaft bore  $d_w$ , please contact our Technical Department.

Coupling two shafts and a hub using SIT-LOCK® 14.

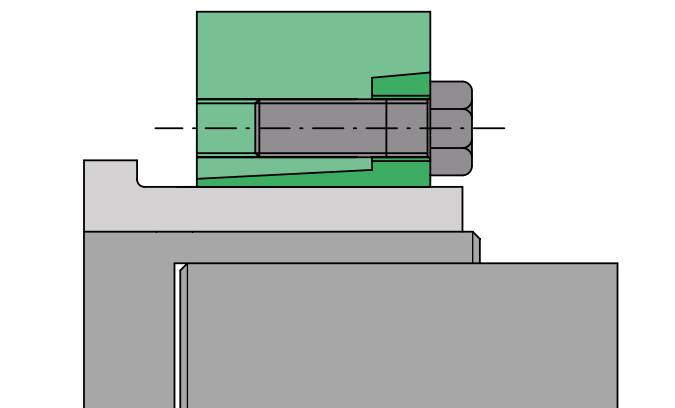

## Customised versions available on request

### SIT-LOCK® 11 SPLIT

- Self-centering
- High transmissible torques
- Available on request for shaft diameters of 24 to 500 mm
- No axial displacement when tightening the screws
- Quick installation and removal

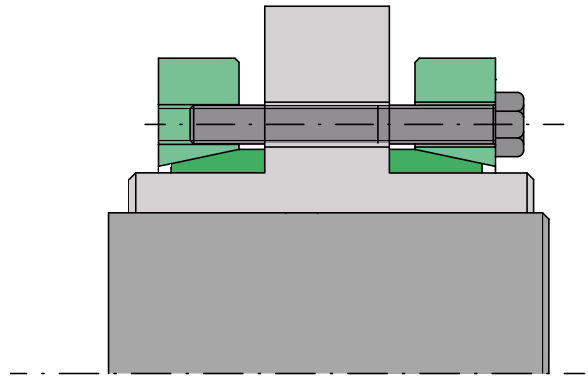

### SIT-LOCK® 11 HALF version A

- Self-centering
- Medium to high transmissible torques
- Available on request for shaft diameters of 24 to 500 mm
- No axial displacement when tightening the screws
- Quick installation and removal
- Reduced axial dimensions

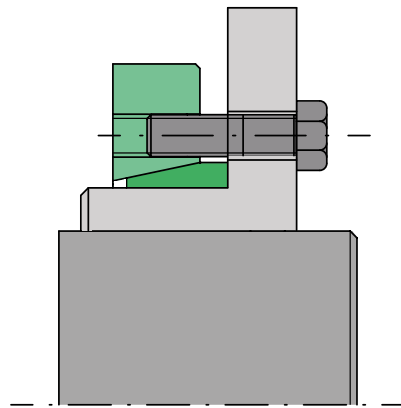

### SIT-LOCK® 11 HALF version B

- Self-centering
- Medium to high transmissible torques
- Available on request for shaft diameters of 24 to 500 mm
- No axial displacement when tightening the screws
- Quick installation and removal
- Reduced axial dimensions

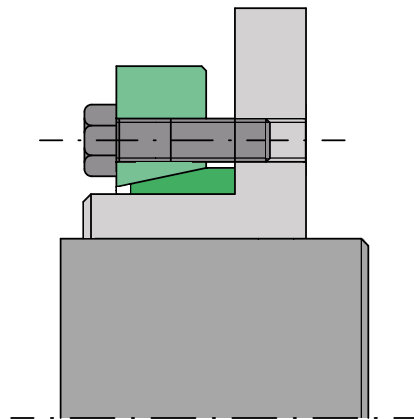

### SIT-LOCK® 11 rigid joint version

- Self-centering
- Available on request for shaft diameters of 24 to 600 mm
- No axial displacement when tightening the screws
- High transmissible torques
- Easy to remove
- No backlash

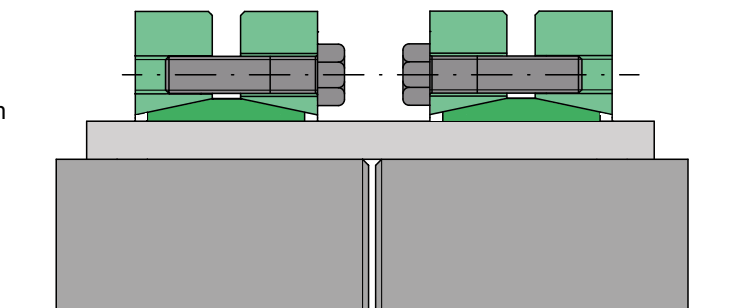

## Customised versions available on request

### SIT-LOCK® 14 special

- Self-centering
- Medium to high transmissible torques
- Available on request for shaft diameters of 24 to 500 mm
- No axial displacement when tightening the screws
- Quick installation and removal
- Reduced axial dimensions
- Excellent concentricity and perpendicularity

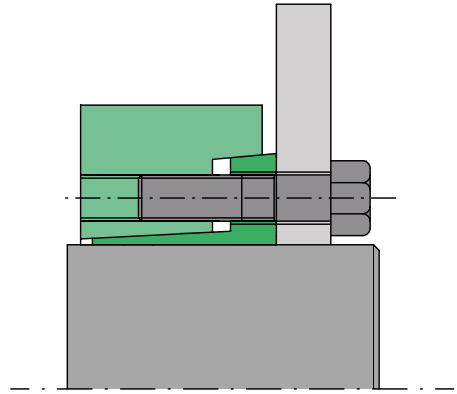

### SIT-LOCK® 14 special for tight spaces

- Self-centering
- Medium to high transmissible torques
- Available on request for shaft diameters of 50 to 500 mm
- No axial displacement when tightening the screws
- Quick installation and removal
- Recommended for applications that require a reduced size
- May be supplied with DIN 912 clamping screws

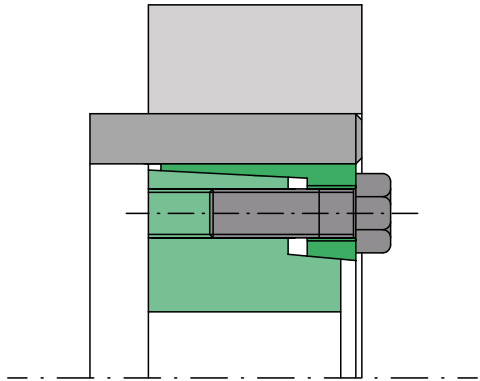

### SIT-LOCK® 11, SIT-LOCK® 14 with electroless nickel plating

- SIT-LOCK® 11 and SIT-LOCK® 14 locking devices can be supplied with electroless nickel plating
- $M_t$ ,  $F_{ax}$ ,  $P_w$  and  $P_n$  values remain unchanged
- Medium to high transmissible torques
- Excellent oxidation protection
- The screws are also supplied with electroless nickel plating
- Particularly recommended for applications in high humidity environments

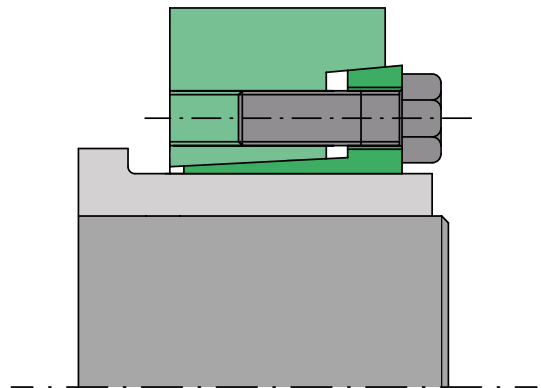

### SIT-LOCK® 11, SIT-LOCK® 14 in stainless steel

- SIT-LOCK® 11 and SIT-LOCK® locking devices 14 can be manufactured and supplied in stainless steel. The screws are also supplied in stainless steel.
- The  $M_t$ ,  $F_{ax}$ ,  $P_w$  and  $P_n$  values are lower than those in the table
- Medium to high transmissible torques
- Highly recommended for applications in the food industry or aggressive environments
- For further information, please contact our Technical Department.

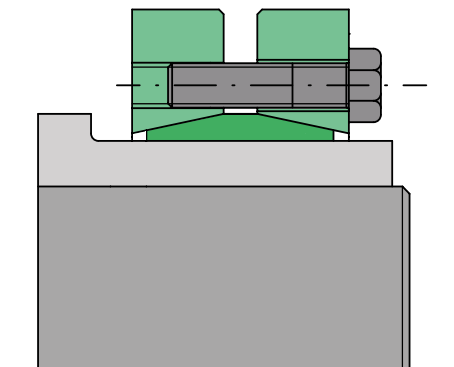



**SIT-LOCK® LOCKING DEVICES  
FOR APPLICATIONS WITH HIGH BENDING MOMENTS**



**HIGH BENDING  
MOMENTS**

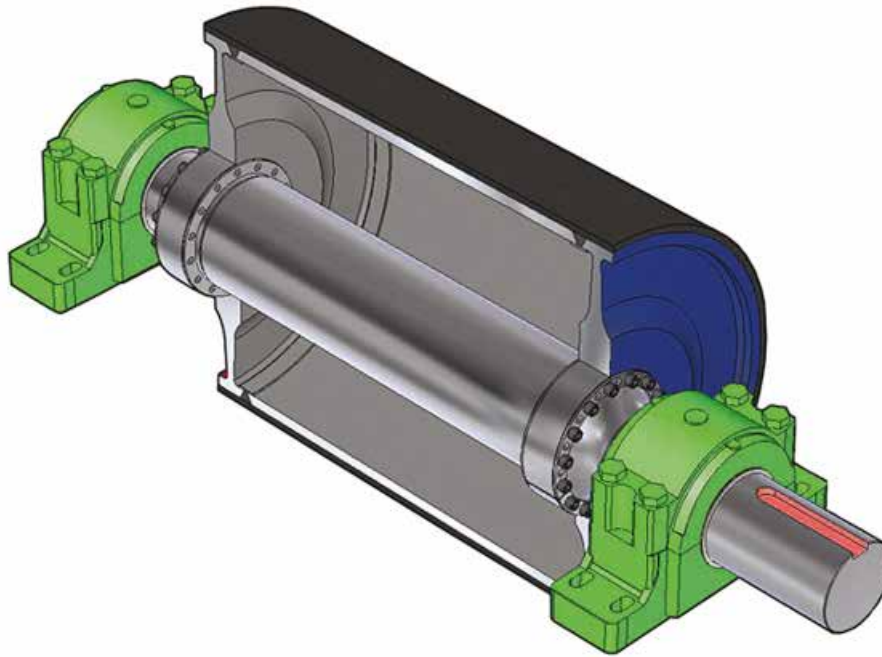

### Bending moment

The bending moment in a shaft-hub coupling is a crucial factor to consider during the design phase. The figure shows an application for clamping a conveyor belt pulley. A typical application that requires simultaneous torque transmission and bending moment.

The bending moment changes the pressure the locking device generates on the shaft and hub contact surfaces.

An excessive bending moment could cause an additional load on the locking device clamping screws causing them to break if the load is excessive.

The pressure generated by the bending moment causes an increase and decrease in the pressure generated by the SIT-LOCK® locking device and may significantly affect the transmissible torque.

The bending moment generates a surface pressure on the shaft and hub that is difficult to quantify. This pressure will not be evenly distributed across the contact surface but will be concentrated at the edges. The magnitude of this pressure depends on many factors and must be verified. It is very important to verify these pressures as they influence the choice of shaft diameter and the correct sizing of the hub.

Checking these pressures is crucial as they affect the choice of shaft diameter and correct hub sizing.

For proper use, the minimum pressure generated on the surfaces must be at least 30 N/mm<sup>2</sup> to avoid oxidation.

Lower values may cause difficulty when removing the coupling.

### Transmissible torque moment

A shaft-hub coupling using SIT-LOCK® frictional locking devices can simultaneously allow a torque  $M_t$ , an axial force  $F_{ax}$  and a radial force (a force that results in a bending moment  $M_b$ ). To determine the final resultant force, these values must be added together in a vector-based way.

### SIT-LOCK® screw tightening torque

The screw tightening torque values are calculated taking into account a friction coefficient between the threads equal to 0.14 (oiled screws and threads).

If necessary, the tightening torque  $M_s$  in the table can be reduced. As a result, the  $M_t$ ,  $F_{ax}$ ,  $P_w$  and  $P_n$  values will vary proportionally. For further information, please contact our Technical Department.

### Tolerances and surface finish

The values shown in the tables are valid when the correct tolerances and surface finishes are used.

Tolerances greater than those indicated can have a significant effect on the transmittable torque.

These are the recommended values:

<b>SIT-LOCK® 1</b> shaft h11 - hub H11	<b>SIT-LOCK® 7, SIT-LOCK® 4C,</b> <b>SIT-LOCK® 20, SIT-LOCK® 4</b> <b>e SIT-LOCK® 22</b> shaft h8 - hub H8
<b>surface finish</b> <b>of shaft and hub <math>R_a</math> max. 16 µm</b>	

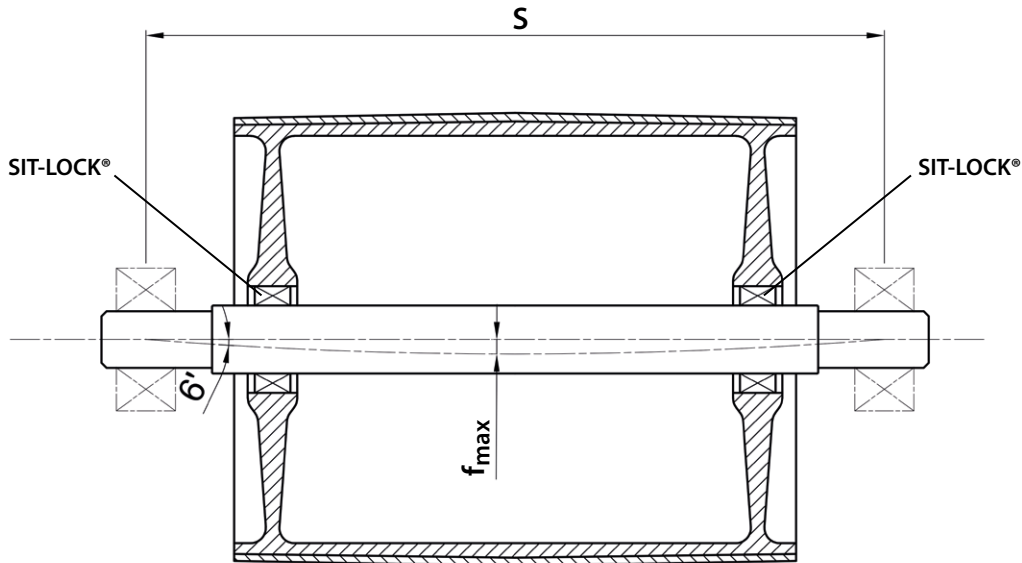

**Conveyor belt pulley installed using a SIT-LOCK® locking device**

First of all, the maximum bending moment of the shaft used for transmission must be checked. The permissible deflection ( $f_{max}$ ) must not exceed 1/2000 of the distance between bearings (s).

Once the maximum bending moment has been checked, check which type of SIT-LOCK® should be used. The tables show the permissible values for proper use. The values shown are calculated with oiled surfaces.

Coefficient of friction taken as: 0.12

**Minimum hub diameter  $D_{min}$**

The following diagram shows how to calculate the minimum hub diameter  $D_{min}$ .

To determine the minimum hub diameter  $D_{min}$ , multiply the coefficient K by the outer diameter D of the chosen SIT-LOCK® locking device.

K depends on the elastic load of the hub material (indicate letter), the pressure generated on the hub ( $P_n$ ) and X which varies according to the shape of the hub (A, B, C).

<b>Application A X=1</b>	<b>Application B X=0,8</b>	<b>Application C X=0,6</b>

$$D_{min} \geq D \times K$$

$$K = \sqrt{\frac{\sigma_{0,2} + (X \cdot P_n)}{\sigma_{0,2} - (X \cdot P_n)}}$$

$\sigma_{0,2}$ : elastic load of hub material	X: varies depending on hub shape (A, B, C)	$P_n$ : pressure generated on the outer SIT-LOCK® diameter (see table)
---	--	--

High bending moment

# SIT-LOCK® 1 internal locking device - not self-centering

no axial displacement	not self-centering
-----------------------	--------------------

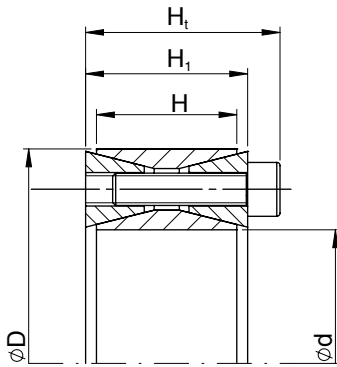

Table of trasmissible torque with **bending moments**

Dimensions [mm]				Clamping screws DIN 912 12.9			Values without bending moment, with tolerances for shaft h11/hub H11				Suggested $M_b$ [Nm]	$M_{tMB}$ with $M_b$ suggested [Nm]	Max $M_b$ [Nm]	$M_{tMB}$ with $M_b$ max [Nm]
d x D	H	H <sub>1</sub>	H <sub>t</sub>	Type	N°	M <sub>s</sub> [Nm]	M <sub>t</sub> [Nm]	F <sub>ax</sub> [kN]	P <sub>w</sub> [N/mm <sup>2</sup> ]	P <sub>n</sub> [N/mm <sup>2</sup> ]				
100 x 145	26	33	45	M12	14	145	11.315	226	231	160	2.489	11.038	7.220	8.712
110 x 155	26	33	45	M12	14	145	12.447	226	210	150	2.738	12.142	7.942	9.583
120 x 165	26	33	45	M12	16	145	15.516	259	220	160	3.414	15.136	9.902	11.946
130 x 180	34	38	50	M12	20	145	21.008	323	194	140	4.622	20.493	13.409	16.172
140 x 190	34	38	50	M12	22	145	24.892	356	198	145	5.476	24.282	15.884	19.165
150 x 200	34	38	50	M12	24	145	29.085	388	202	150	6.399	28.372	18.566	22.389
160 x 210	34	38	50	M12	26	145	33.616	420	205	155	7.396	32.792	21.454	25.880
170 x 225	38	44	58	M14	22	230	40.426	476	195	150	8.894	39.436	21.600	34.172
180 x 235	38	44	58	M14	24	230	46.692	519	201	155	10.272	45.548	24.950	39.467
190 x 250	46	52	66	M14	28	230	57.504	605	184	140	12.651	56.095	30.725	48.607
200 x 260	46	52	66	M14	30	230	64.860	649	187	145	14.269	63.271	34.652	54.827
220 x 285	50	56	72	M16	26	355	84.601	769	185	145	18.612	82.528	32.700	78.026
240 x 305	50	56	72	M16	30	355	106.488	887	196	155	23.427	103.879	41.161	98.211
260 x 325	50	56	72	M16	34	355	130.741	1.006	205	165	28.763	127.538	50.536	120.579
280 x 355	60	66	84	M18	32	485	157.360	1.124	177	140	34.619	153.505	38.450	152.590
300 x 375	60	66	84	M18	36	485	189.690	1.265	186	150	41.732	185.043	46.346	183.941
320 x 405	72	78	98	M20	36	690	259.696	1.623	187	150	57.133	253.333	37.300	257.003
340 x 425	72	78	98	M20	36	690	275.927	1.623	176	140	60.704	269.167	39.631	273.066
360 x 455	84	90	112	M22	36	930	360.738	2.004	176	140	79.362	351.900	74.650	352.930
380 x 475	84	90	112	M22	36	930	380.779	2.004	167	135	83.771	371.450	78.797	372.537
400 x 495	84	90	112	M22	36	930	400.820	2.004	158	130	88.180	391.000	82.944	392.144
420 x 515	84	90	112	M22	40	930	467.628	2.227	167	135	102.878	456.171	96.769	457.506
440 x 545	96	102	126	M24	40	1200	557.304	2.533	159	130	122.607	543.650	113.200	545.686
460 x 565	96	102	126	M24	40	1200	582.636	2.533	152	125	128.180	568.361	118.345	570.490
480 x 585	96	102	126	M24	42	1200	638.376	2.660	153	125	140.443	622.736	129.665	625.069
500 x 605	96	102	126	M24	44	1200	696.650	2.787	154	125	153.263	679.582	141.500	682.128
520 x 630	96	102	126	M24	45	1200	740.974	2.850	151	125	163.014	722.820	150.505	725.528
540 x 650	96	102	126	M24	45	1200	769.473	2.850	146	120	169.284	750.621	156.293	753.433
560 x 670	96	102	126	M24	48	1200	851.172	3.040	150	125	187.258	830.318	172.887	833.429
580 x 690	96	102	126	M24	50	1200	918.285	3.167	151	125	202.023	895.787	186.523	899.142
600 x 710	96	102	126	M24	50	1200	949.950	3.167	146	125	208.989	926.676	192.955	930.147

$M_b$	Bending Moment	Nm
$M_s$	Screw tightening torque	Nm
$M_t$	Transmissible torque without $M_b$	Nm
$F_{ax}$	Permissible axial force without $M_b$	kN
$P_w$	Pressure generated at the shaft without $M_b$	N/mm <sup>2</sup>
$P_n$	Pressure generated at the hub without $M_b$	N/mm <sup>2</sup>
Suggested $M_b$	Recommended bending moment	Nm
$M_{tMB}$ with $M_b$ suggested	transmissible torque with $M_b$ suggested	Nm
$M_b$ max	Bending moment maximum	Nm
$M_{tMB}$ with $M_b$ max	Maximum transmissible torque with $M_b$	Nm

# SIT-LOCK® 7 internal locking device - self-centering

no axial displacement	self-centering
-----------------------	----------------

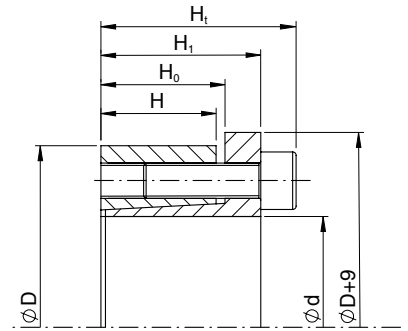

Table of trasmissible torque with **bending moments**

Dimensions [mm]					Clamping screws DIN 912 12.9			Values without bending moment, with tolerances for shaft h8/hub H8				Suggested $M_b$ [Nm]	$M_{tMB}$ with $M_b$ suggested [Nm]	Max $M_b$ [Nm]	$M_{tMB}$ with $M_b$ max [Nm]
d x D	H	H <sub>0</sub>	H <sub>1</sub>	H <sub>t</sub>	Type	N°	$M_s$ [Nm]	$M_t$ [Nm]	$F_{ax}$ [kN]	$P_w$ [N/mm <sup>2</sup> ]	$P_n$ [N/mm <sup>2</sup> ]				
70 x 110	24	30	40	50	M10	8	83	4.669	133	211	135	1.401	4.454	2.335	4.043
75 x 115	24	30	40	50	M10	8	83	5.003	133	197	130	1.501	4.772	2.502	4.332
80 x 120	24	30	40	50	M10	8	83	5.336	133	184	125	1.601	5.090	2.669	4.621
85 x 125	24	30	40	50	M10	9	83	6.379	150	195	135	1.914	6.085	3.190	5.525
90 x 130	24	30	40	50	M10	9	83	6.755	150	184	130	2.026	6.443	3.377	5.849
95 x 135	24	30	40	50	M10	10	83	7.923	167	194	135	2.377	7.558	3.961	6.862
100 x 145	26	32	44	56	M12	8	145	9.715	194	198	135	2.915	9.268	7.220	6.500
110 x 155	26	32	44	56	M12	8	145	10.687	194	180	130	3.206	10.194	7.942	7.150
120 x 165	26	32	44	56	M12	9	145	13.116	219	186	135	3.935	12.512	9.747	8.776
130 x 180	34	40	54	64	M12	12	145	18.941	291	175	125	5.682	18.069	14.079	12.671
140 x 190	34	40	54	68	M14	9	230	20.993	300	167	125	6.298	20.026	10.180	18.360
150 x 200	34	40	54	68	M14	10	230	24.990	333	173	130	7.497	23.839	12.119	21.855
160 x 210	34	40	54	68	M14	11	230	29.328	367	179	135	8.798	27.977	14.220	25.650
170 x 225	44	50	64	78	M14	12	230	33.992	400	142	105	10.197	32.426	16.482	29.728
180 x 235	44	50	64	78	M14	12	230	35.991	400	134	105	10.797	34.333	17.451	31.477
190 x 250	44	50	64	78	M14	15	230	47.481	500	159	120	14.244	45.294	23.026	41.524
200 x 260	44	50	64	78	M14	15	230	49.980	500	151	115	14.994	47.678	24.238	43.709
220 x 285	50	56	75	91	M16	12	355	61.138	556	134	105	18.341	58.322	32.700	51.658
240 x 305	50	56	75	91	M16	15	355	83.364	695	154	120	25.009	79.524	44.591	70.436
260 x 325	50	56	75	91	M16	16	355	96.330	741	151	120	28.899	91.893	51.527	81.390
280 x 355	60	66	87	105	M18	16	485	124.824	892	141	110	37.447	119.075	42.500	117.366
300 x 375	60	66	87	105	M18	18	485	150.465	1.003	148	120	45.140	143.534	51.228	141.476
320 x 405	74	81	101	121	M20	18	690	208.208	1.301	146	115	62.462	198.618	70.900	195.765
340 x 425	74	81	101	121	M20	21	690	258.094	1.518	160	130	77.428	246.206	87.886	242.669
360 x 455	86	94	116	138	M22	18	930	291.564	1.620	139	110	87.469	278.134	97.750	274.690
380 x 475	86	94	116	138	M22	21	930	359.062	1.890	153	125	107.719	342.523	120.377	338.282
400 x 495	86	94	116	138	M22	21	930	377.960	1.890	146	120	113.388	360.551	126.713	356.086
420 x 515	86	94	116	138	M22	21	930	396.858	1.890	139	115	119.057	378.578	133.049	373.891
440 x 535	86	94	116	138	M22	21	930	415.756	1.890	132	110	124.727	396.606	139.384	391.695
460 x 555	86	94	116	138	M22	22	930	455.354	1.980	133	110	136.606	434.380	152.659	429.002
480 x 575	86	94	116	138	M22	24	930	518.352	2.160	139	115	155.506	494.476	173.778	488.354
500 x 595	86	94	116	138	M22	24	930	539.950	2.160	133	110	161.985	515.079	181.019	508.703

- $M_b$  Bending Moment
- $M_s$  Screw tightening torque
- $M_t$  Transmissible torque without  $M_b$
- $F_{ax}$  Permissible axial force without  $M_b$
- $P_w$  Pressure generated at the shaft without  $M_b$
- $P_n$  Pressure generated at the hub without  $M_b$
- Suggested  $M_b$  Recommended bending moment
- $M_{tMB}$  with  $M_b$  suggested transmissible torque with  $M_b$  suggested
- $M_b$  max Bending moment maximum
- $M_{tMB}$  with  $M_b$  max Maximum transmissible torque with  $M_b$

- Nm
- Nm
- kN
- N/mm<sup>2</sup>
- N/mm<sup>2</sup>
- Nm
- Nm
- Nm
- Nm

High bending moment

## SIT-LOCK® 4C internal locking device - self-centering

no axial displacement	self-centering
-----------------------	----------------

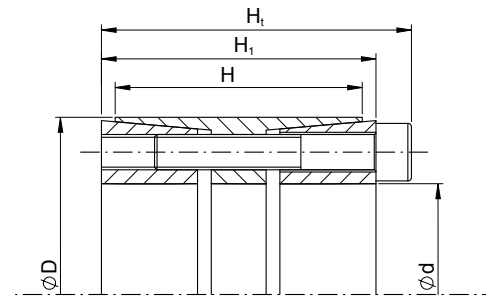

Table of transmissible torque with **bending moments**

Dimensions [mm]				Clamping screws DIN 912 12.9			Values without bending moment, with tolerances for shaft h8/hub H8				Suggested $M_b$ [Nm]	$M_{tMB}$ with $M_b$ suggested [Nm]	Max $M_b$ [Nm]	$M_{tMB}$ with $M_b$ max [Nm]
d x D	H	H <sub>1</sub>	H <sub>t</sub>	Type	N°	$M_s$ [Nm]	$M_t$ [Nm]	$F_{ax}$ [kN]	$P_w$ [N/mm <sup>2</sup> ]	$P_n$ [N/mm <sup>2</sup> ]				
70 x 110	50	60	70	M10	8	83	7.158	205	194	100	2.505	6.705	5.050	5.072
75 x 115	50	60	70	M10	8	83	7.669	205	181	95	2.684	7.184	5.410	5.435
80 x 120	50	60	70	M10	10	83	10.224	256	212	115	3.578	9.577	7.210	7.249
85 x 125	50	60	70	M10	10	83	10.863	256	199	110	3.802	10.176	7.670	7.693
90 x 130	50	60	70	M10	11	83	12.650	281	207	115	4.427	11.849	8.930	8.959
95 x 135	50	60	70	M10	11	83	13.352	281	196	110	4.673	12.508	9.420	9.463
100 x 145	60	70	82	M12	10	145	18.605	372	206	115	6.512	17.428	10.100	15.625
110 x 155	60	70	82	M12	10	145	20.466	372	187	105	7.163	19.171	11.110	17.187
120 x 165	60	70	82	M12	11	145	24.558	409	189	110	8.595	23.005	13.330	20.625
130 x 180	65	79	91	M12	14	145	33.865	521	201	120	11.853	31.723	18.380	28.443
140 x 190	65	79	91	M12	15	145	39.074	558	200	120	13.676	36.603	21.210	32.816
150 x 200	65	79	91	M12	15	145	41.865	558	186	115	14.653	39.217	22.730	35.157
160 x 210	65	79	91	M12	16	145	47.632	595	186	115	16.671	44.619	25.860	40.001
170 x 225	78	92	106	M14	15	230	65.102	766	187	115	22.786	60.984	30.950	57.274
180 x 235	78	92	106	M14	15	230	68.931	766	176	110	24.126	64.571	32.770	60.643
190 x 250	88	102	116	M14	16	230	77.606	817	154	100	27.162	72.697	36.900	68.272
200 x 260	88	102	116	M14	18	230	91.900	919	165	105	32.165	86.087	43.690	80.850
220 x 285	96	111	127	M16	15	355	117.084	1.064	160	105	40.979	109.678	75.900	89.151
240 x 305	96	111	127	M16	20	355	170.304	1.419	196	130	59.606	159.532	110.400	129.674
260 x 325	96	111	127	M16	20	355	184.496	1.419	181	120	64.574	172.827	119.600	140.480
280 x 355	96	111	131	M20	15	690	232.610	1.662	207	130	81.414	217.897	112.200	203.761
300 x 375	96	111	131	M20	16	690	265.845	1.772	206	130	93.046	249.030	128.230	232.875
320 x 405	124	136	156	M20	20	690	354.464	2.215	177	115	124.062	332.044	170.970	310.506
340 x 425	124	136	156	M20	20	690	376.618	2.215	166	110	131.816	352.797	181.660	329.910
360 x 455	140	155	177	M22	20	930	496.386	2.758	172	115	173.735	464.989	286.000	405.713
380 x 475	140	155	177	M22	20	930	523.963	2.758	163	110	183.387	490.822	301.890	428.252
400 x 495	140	155	177	M22	22	930	606.700	3.034	170	115	212.345	568.326	349.560	495.876
420 x 515	140	155	177	M22	24	930	694.932	3.309	177	120	243.226	650.977	400.400	567.988
440 x 535	140	155	177	M22	24	930	728.024	3.309	169	115	254.808	681.976	419.470	595.033
460 x 555	140	155	177	M22	24	930	761.116	3.309	162	115	266.391	712.975	438.530	622.084
480 x 575	140	155	177	M22	25	930	827.304	3.447	161	115	289.556	774.977	476.670	676.179
500 x 595	140	155	177	M22	25	930	861.775	3.447	155	110	301.621	807.267	496.530	704.354

$M_b$	Bending Moment	Nm
$M_s$	Screw tightening torque	Nm
$M_t$	Transmissible torque without $M_b$	Nm
$F_{ax}$	Permissible axial force without $M_b$	kN
$P_w$	Pressure generated at the shaft without $M_b$	N/mm <sup>2</sup>
$P_n$	Pressure generated at the hub without $M_b$	N/mm <sup>2</sup>
Suggested $M_b$	Recommended bending moment	Nm
$M_{tMB}$ with $M_b$ suggested	transmissible torque with $M_b$ suggested	Nm
$M_b$ max	Bending moment maximum	Nm
$M_{tMB}$ with $M_b$ max	Maximum transmissible torque with $M_b$	Nm

## SIT-LOCK® 20 internal locking device - self-centering

no axial displacement	self-centering
-----------------------	----------------

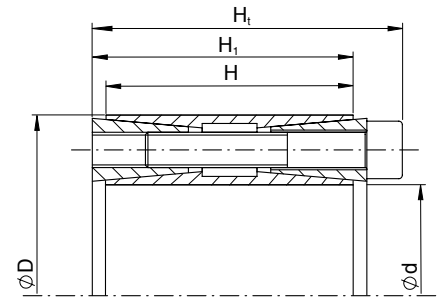

Table of trasmissible torque with **bending moments**

Dimensions [mm]				Clamping screws DIN 912 12.9			Values without bending moment, with tolerances for shaft h8/hub H8					Suggested $M_b$ [Nm]	$M_{iBM}$ with $M_b$ suggested [Nm]	Max $M_b$ [Nm]	$M_{iBM}$ with $M_b$ max [Nm]
d x D	H	H <sub>1</sub>	H <sub>i</sub>	Type	N°	$M_s$ [Nm]	$M_t$ [Nm]	$F_{ax}$ [kN]	$P_w$ [N/mm <sup>2</sup> ]	$P_n$ [N/mm <sup>2</sup> ]					
60 x 90	56	64	72	M8	10	41	5.820	194	153	100	2.212	5.383	2.910	5.040	
65 x 95	56	64	72	M8	10	41	6.305	194	141	95	2.396	5.832	3.153	5.460	
70 x 110	70	78	88	M10	10	83	10.784	308	167	105	4.098	9.975	5.392	9.339	
75 x 115	70	78	88	M10	10	83	11.554	308	156	100	4.390	10.687	5.777	10.006	
80 x 120	70	78	88	M10	12	83	14.788	370	175	115	5.619	13.679	7.394	12.807	
85 x 125	70	78	88	M10	12	83	15.712	370	165	110	5.971	14.534	7.856	13.607	
90 x 130	70	78	88	M10	12	83	16.637	370	156	110	6.322	15.389	8.318	14.408	
95 x 135	70	78	88	M10	12	83	17.561	370	147	105	6.673	16.243	8.780	15.208	
100 x 145	90	100	112	M12	12	145	26.915	538	159	110	10.228	24.896	13.458	23.309	
110 x 155	90	100	112	M12	12	145	29.607	538	144	100	11.250	27.386	14.803	25.640	
120 x 165	90	100	112	M12	14	145	37.680	628	154	110	14.318	34.853	18.840	32.632	
130 x 180	104	116	130	M14	12	230	48.009	739	145	105	18.243	44.408	24.005	41.577	
140 x 190	104	116	130	M14	14	230	60.319	862	157	115	22.921	55.794	30.160	52.238	
150 x 200	104	116	130	M14	16	230	73.860	985	167	125	28.067	68.320	36.930	63.965	
160 x 210	104	116	130	M14	16	230	78.784	985	157	120	29.938	72.874	39.392	68.229	
170 x 225	134	146	162	M16	14	355	101.796	1.198	139	105	38.682	94.160	50.898	88.158	
180 x 235	134	146	162	M16	16	355	123.174	1.369	151	115	46.806	113.934	61.587	106.672	
190 x 250	134	146	162	M16	16	355	130.017	1.369	143	110	49.406	120.264	65.009	112.598	
200 x 260	134	146	162	M16	16	355	136.860	1.369	135	105	52.007	126.594	68.430	118.524	
220 x 285	134	146	162	M16	20	355	188.188	1.711	154	120	71.511	174.071	94.094	162.976	
240 x 305	134	146	162	M16	22	355	225.828	1.882	155	120	85.815	208.888	112.914	195.573	
260 x 325	134	146	162	M16	22	355	244.647	1.882	143	115	92.966	226.295	122.324	211.871	
280 x 355	165	177	197	M20	20	690	373.870	2.671	153	120	142.071	345.825	186.935	323.781	
300 x 375	165	177	197	M20	22	690	440.640	2.938	157	125	167.443	407.586	220.320	381.605	
320 x 405	165	177	197	M20	22	690	470.016	2.938	148	115	178.606	434.758	235.008	407.046	
340 x 425	165	177	197	M20	24	690	544.782	3.205	152	120	207.017	503.916	272.391	471.795	
360 x 455	190	202	224	M22	22	930	658.206	3.657	142	110	250.118	608.832	329.103	570.023	
380 x 475	190	202	224	M22	26	930	821.085	4.322	159	125	312.012	759.493	410.543	711.080	
400 x 495	190	202	224	M22	26	930	864.300	4.322	151	120	328.434	799.466	432.150	748.506	

$M_b$	Bending Moment	Nm
$M_s$	Screw tightening torque	Nm
$M_t$	Transmissible torque without $M_b$	Nm
$F_{ax}$	Permissible axial force without $M_b$	kN
$P_w$	Pressure generated at the shaft without $M_b$	N/mm <sup>2</sup>
$P_n$	Pressure generated at the hub without $M_b$	N/mm <sup>2</sup>
Suggested $M_b$	Recommended bending moment	Nm
$M_{iBM}$ with $M_b$ suggested	transmissible torque with $M_b$ suggested	Nm
$M_b$ max	Bending moment maximum	Nm
$M_{iBM}$ with $M_b$ max	Maximum transmissible torque with $M_b$	Nm

# SIT-LOCK® 4 internal locking device - self-centering

no axial displacement	self-centering
-----------------------	----------------

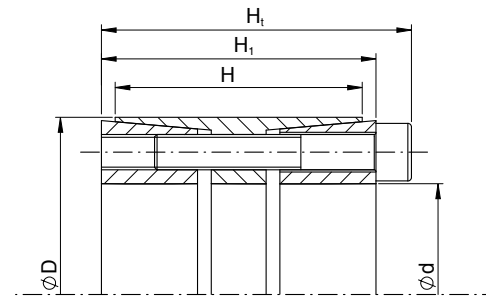

Table of trasmissible torque with **bending moments**

Dimensions [mm]				Clamping screws DIN 912 12.9			Values without bending moment, with tolerances for shaft h8/hub H8					Suggested $M_b$ [Nm]	$M_{iBM}$ with $M_b$ suggested [Nm]	Max $M_b$ [Nm]	$M_{iBM}$ with $M_b$ max [Nm]
d x D	H	$H_1$	$H_1$	Type	N°	$M_s$ [Nm]	$M_t$ [Nm]	$F_{ax}$ [kN]	$P_w$ [N/mm <sup>2</sup> ]	$P_n$ [N/mm <sup>2</sup> ]					
60 x 90	58	62	70	M8	10	41	6.303	210	186	105	2.206	5.904	3.025	5.529	
65 x 95	58	62	70	M8	10	41	6.828	210	171	100	2.390	6.396	3.278	5.990	
70 x 110	70	76	86	M10	10	83	11.676	334	211	115	4.087	10.937	5.604	10.243	
75 x 115	70	76	86	M10	10	83	12.510	334	197	110	4.379	11.719	6.005	10.975	
80 x 120	70	76	86	M10	12	83	16.012	400	221	125	5.604	14.999	7.686	14.047	
85 x 125	70	76	86	M10	12	83	17.013	400	208	120	5.954	15.937	8.166	14.925	
90 x 130	70	76	86	M10	12	83	18.014	400	197	115	6.305	16.874	8.646	15.803	
95 x 135	70	76	86	M10	12	83	19.014	400	186	110	6.655	17.812	9.127	16.681	
100 x 145	92	98	110	M12	12	145	29.145	583	193	115	10.201	27.302	13.990	25.568	
110 x 155	92	98	110	M12	12	145	32.060	583	176	110	11.221	30.032	15.389	28.125	
120 x 165	92	98	110	M12	14	145	40.800	680	188	120	14.280	38.219	19.584	35.793	
130 x 180	108	114	128	M14	12	230	51.981	800	174	110	18.193	48.693	24.951	45.601	
140 x 190	108	114	128	M14	14	230	65.310	933	188	120	22.859	61.179	31.349	57.294	
150 x 200	108	114	128	M14	16	230	79.973	1.066	201	130	27.990	74.914	38.387	70.157	
160 x 210	108	146	162	M14	16	230	85.304	1.066	188	125	29.856	79.908	40.946	74.835	
170 x 225	136	146	162	M16	14	355	110.228	1.297	169	110	38.580	103.256	52.909	96.700	
180 x 235	136	146	162	M16	16	355	133.380	1.482	182	125	46.683	124.944	64.022	117.010	
190 x 250	136	146	162	M16	16	355	140.790	1.482	172	115	49.277	131.885	67.579	123.511	
200 x 260	136	146	162	M16	16	355	148.200	1.482	164	110	51.870	138.826	71.136	130.011	
220 x 285	136	146	162	M16	20	355	203.775	1.853	186	125	71.321	190.886	97.812	178.765	
240 x 305	136	146	162	M16	22	355	244.536	2.038	188	130	85.588	229.069	117.377	214.524	
260 x 325	136	146	162	M16	22	355	264.914	2.038	173	120	92.720	248.158	127.159	232.401	
280 x 355	138	148	168	M20	20	690	404.838	2.892	232	155	141.693	379.232	194.322	355.152	
300 x 375	165	177	197	M20	22	690	477.135	3.181	194	135	166.997	446.956	229.025	418.576	
320 x 405	165	177	197	M20	22	690	508.944	3.181	182	125	178.130	476.753	244.293	446.481	
340 x 425	165	177	197	M20	24	690	589.917	3.470	187	130	206.471	552.605	283.160	517.516	
360 x 455	188	202	224	M22	22	930	712.728	3.960	176	125	249.455	667.648	342.109	625.254	
380 x 475	188	202	224	M22	26	930	889.105	4.680	197	140	311.187	832.869	426.770	779.984	
400 x 495	188	202	224	M22	26	930	935.900	4.680	187	135	327.565	876.704	449.232	821.036	

- $M_b$  Bending Moment Nm
- $M_s$  Screw tightening torque Nm
- $M_t$  Transmissible torque without  $M_b$  Nm
- $F_{ax}$  Permissible axial force without  $M_b$  kN
- $P_w$  Pressure generated at the shaft without  $M_b$  N/mm<sup>2</sup>
- $P_n$  Pressure generated at the hub without  $M_b$  N/mm<sup>2</sup>
- Suggested  $M_b$  Recommended bending moment Nm
- $M_{iBM}$  with  $M_b$  suggested transmissible torque with  $M_b$  suggested Nm
- $M_b$  max Bending moment maximum Nm
- $M_{iBM}$  with  $M_b$  max Maximum transmissible torque with  $M_b$  Nm

# SIT-LOCK® 22 internal locking device

no axial displacement	self-centering
-----------------------	----------------

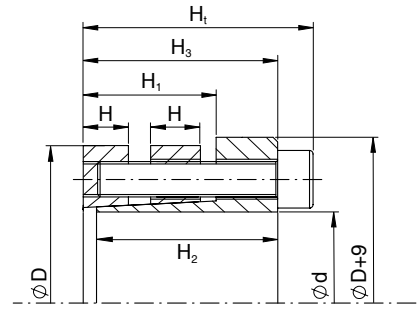

## Table of transmissible torque with bending moments

Dimensions [mm]						Clamping screws DIN 912 12.9						Values without bending moment, with tolerances for shaft h8/hub H8										Max $M_b$ [Nm]	$M_{tBM}$ with $M_b$ max [Nm]
d x D	H	H <sub>1</sub>	H <sub>2</sub>	H <sub>3</sub>	H <sub>t</sub>	Type	N°	M <sub>s</sub> [Nm]	Type	N°	M <sub>s</sub> [Nm]	M <sub>t1</sub> [Nm]	M <sub>t2</sub> [Nm]	M <sub>tTOT</sub> [Nm]	F <sub>ax1</sub> [kN]	F <sub>ax2</sub> [kN]	F <sub>axTOT</sub> [kN]	P <sub>w1</sub> [N/mm <sup>2</sup> ]	P <sub>w2</sub> [N/mm <sup>2</sup> ]	P <sub>n1</sub> [N/mm <sup>2</sup> ]	P <sub>n2</sub> [N/mm <sup>2</sup> ]		
30 x 60	15	36	45	48	56	M8	4	41	M6	4	17	614	332	945	41	22	63	241	130	120	65	614	718
35 x 65	15	36	45	48	56	M8	4	41	M6	5	17	716	485	1.201	41	28	69	207	140	110	75	780	912
40 x 70	15	36	45	48	56	M8	5	41	M6	5	17	1.022	554	1.576	51	28	79	226	122	130	70	1.024	1.198
45 x 80	18	42	54	57	67	M10	4	83	M8	5	41	1.460	1.150	2.610	65	51	116	213	167	120	95	1.697	1.983
50 x 85	18	42	54	57	67	M10	5	83	M8	5	41	2.030	1.278	3.308	81	51	132	239	151	140	90	2.150	2.513
55 x 90	18	42	54	57	67	M10	5	83	M8	5	41	2.233	1.405	3.638	81	51	132	218	137	135	85	2.365	2.765
60 x 95	18	42	54	57	67	M10	6	83	M8	6	41	2.922	1.842	4.764	97	61	159	239	151	150	95	3.097	3.620
65 x 100	18	42	54	57	67	M10	6	83	M8	6	41	3.166	1.996	5.161	97	61	159	221	139	145	90	3.355	3.922
70 x 115	24	58	70	76	88	M12	6	145	M10	6	83	4.963	3.409	8.372	142	97	239	224	154	135	95	5.442	6.362
80 x 125	24	58	70	76	88	M12	7	145	M10	7	83	6.620	4.548	11.168	166	114	279	229	157	145	100	7.259	8.487
90 x 135	24	58	70	76	88	M12	7	145	M10	7	83	7.448	5.117	12.564	166	114	279	203	140	135	95	8.167	9.548
100 x 150	26	61	78	82	96	M14	7	230	M12	7	145	11.355	8.275	19.630	227	166	393	232	169	155	115	12.760	14.918
110 x 160	26	61	78	82	96	M14	7	230	M12	7	145	12.491	9.103	21.593	227	166	393	211	153	145	105	14.035	16.409
120 x 170	26	61	78	82	96	M14	7	230	M12	7	145	13.626	9.930	23.556	227	166	393	193	141	135	100	15.311	17.901
130 x 190	30	71	90	95	111	M16	8	355	M14	8	230	23.446	16.868	40.313	361	260	620	245	176	170	120	26.203	30.635
140 x 200	30	71	90	95	111	M16	8	355	M14	8	230	25.249	18.165	43.414	361	260	620	228	164	160	115	28.219	32.992
150 x 210	30	71	90	95	111	M16	8	355	M14	8	230	27.053	19.463	46.515	361	260	620	213	153	150	110	30.235	35.348
160 x 220	30	71	90	95	111	M16	8	355	M14	8	230	28.856	20.760	49.616	361	260	620	199	143	145	105	32.250	37.705
170 x 240	40	92	114	122	142	M20	8	690	M16	8	355	47.855	30.660	78.515	563	361	924	220	141	155	100	51.034	59.666
180 x 250	40	92	114	122	142	M20	8	690	M16	8	355	50.670	32.463	83.133	563	361	924	207	133	150	95	54.036	63.176
190 x 260	40	92	114	122	142	M20	8	690	M16	8	355	53.485	34.267	87.752	563	361	924	196	126	145	90	57.038	66.685
200 x 270	40	92	114	122	142	M20	10	690	M16	10	355	70.370	45.080	115.450	704	451	1.155	233	149	175	110	75.043	87.734
220 x 290	40	92	114	122	142	M20	10	690	M16	10	355	77.407	49.588	126.995	704	451	1.155	212	136	160	105	82.547	96.508
240 x 310	40	92	114	122	142	M20	12	690	M16	12	355	101.340	64.920	166.260	845	541	1.386	233	149	180	115	108.069	126.347
260 x 330	40	92	114	122	142	M20	12	690	M16	12	355	109.785	70.330	180.115	845	541	1.386	215	138	170	110	117.075	136.876
280 x 365	45	108	135	144	168	M24	10	1200	M20	10	690	141.624	98.518	240.142	1.012	704	1.715	213	148	165	115	156.092	182.492
300 x 385	45	108	135	144	168	M24	10	1200	M20	10	690	151.740	105.555	257.295	1.012	704	1.715	199	138	155	110	167.242	195.527
320 x 405	45	108	135	144	168	M24	12	1200	M20	12	690	194.224	135.120	329.344	1.214	845	2.058	224	156	175	125	214.074	250.280
340 x 425	45	108	135	144	168	M24	14	1200	M20	14	690	240.754	167.484	408.238	1.416	985	2.401	246	171	195	135	265.355	310.234
360 x 445	45	108	135	144	168	M24	14	1200	M20	14	690	254.916	177.336	432.252	1.416	985	2.401	232	161	190	130	280.964	328.483
380 x 465	45	108	135	144	168	M24	16	1200	M20	16	690	307.534	213.940	521.474	1.619	1.126	2.745	251	175	205	145	338.958	396.286
400 x 485	45	108	135	144	168	M24	16	1200	M20	16	690	323.720	225.200	548.920	1.619	1.126	2.745	239	166	195	135	356.798	417.143
420 x 505	45	108	135	144	168	M24	16	1200	M20	16	690	339.906	236.460	576.366	1.619	1.126	2.745	227	158	190	130	374.638	438.000
440 x 525	59	147	167	178	202	M24	16	1200	M20	16	690	356.092	247.720	603.812	1.619	1.126	2.745	165	115	140	95	392.478	458.857
460 x 545	59	147	167	178	202	M24	16	1200	M20	16	690	372.278	258.980	631.258	1.619	1.126	2.745	158	110	135	95	410.318	479.715
480 x 565	59	147	167	178	202	M24	16	1200	M20	16	690	388.464	270.240	658.704	1.619	1.126	2.745	152	105	130	90	428.158	500.572
500 x 585	59	147	167	178	202	M24	18	1200	M20	18	690	455.225	316.675	771.900	1.821	1.267	3.088	164	114	140	95	501.735	586.593
520 x 605	59	147	167	178	202	M24	18	1200	M20	18	690	473.434	329.342	802.776	1.821	1.267	3.088	157	110	135	95	521.804	610.057
540 x 625	59	147	167	178	202	M24	18	1200	M20	18	690	491.643	342.009	833.652	1.821	1.267	3.088	152	105	130	90	541.874	633.521
560 x 645	59	147	167	178	202	M24	18	1200	M20	18	690	509.852	354.676	864.528	1.821	1.267	3.088	146	102	125	90	561.943	656.984
580 x 665	59	147	167	178	202	M24	20	1200	M20	20	690	586.728	408.175	994.903	2.023	1.408	3.431	157	109	135	95	646.687	756.061
600 x 685	59	147	167	178	202	M24	20	1200	M20	20	690	606.960	422.250	1.029.210	2.023	1.408	3.431	152	105	135	90	668.987	782.132

- $M_b$  Bending Moment
- $M_s$  Screw tightening torque
- $M_{t1}$  Transmissible torque without  $M_b$  from the ring 1
- $M_{t2}$  Transmissible torque without  $M_b$  from the ring 2
- $M_{tTOT}$  Total transmissible torque without  $M_b$
- $F_{ax1}$  Permissible axial force without  $M_b$  from the ring 1
- $F_{ax2}$  Permissible axial force without  $M_b$  from the ring 2
- $F_{axTOT}$  Total permissible axial force without  $M_b$
- $P_{w1}$  Pressure generated at the shaft without  $M_b$  from the ring 1
- $P_{w2}$  Pressure generated at the shaft without  $M_b$  from the ring 2
- $P_{n1}$  Pressure generated at the hub without  $M_b$  from the ring 1
- $P_{n2}$  Pressure generated at the hub without  $M_b$  from the ring 2
- $M_b$  max Maximum bending moment
- $M_{tMB}$  con  $M_b$  max Maximum transmissible torque with  $M_b$

High bending moment



Quarry excavator application: SIT-LOCK® 4 COMPACT for drums and SIT-LOCK® 14 for bucket wheel locking.

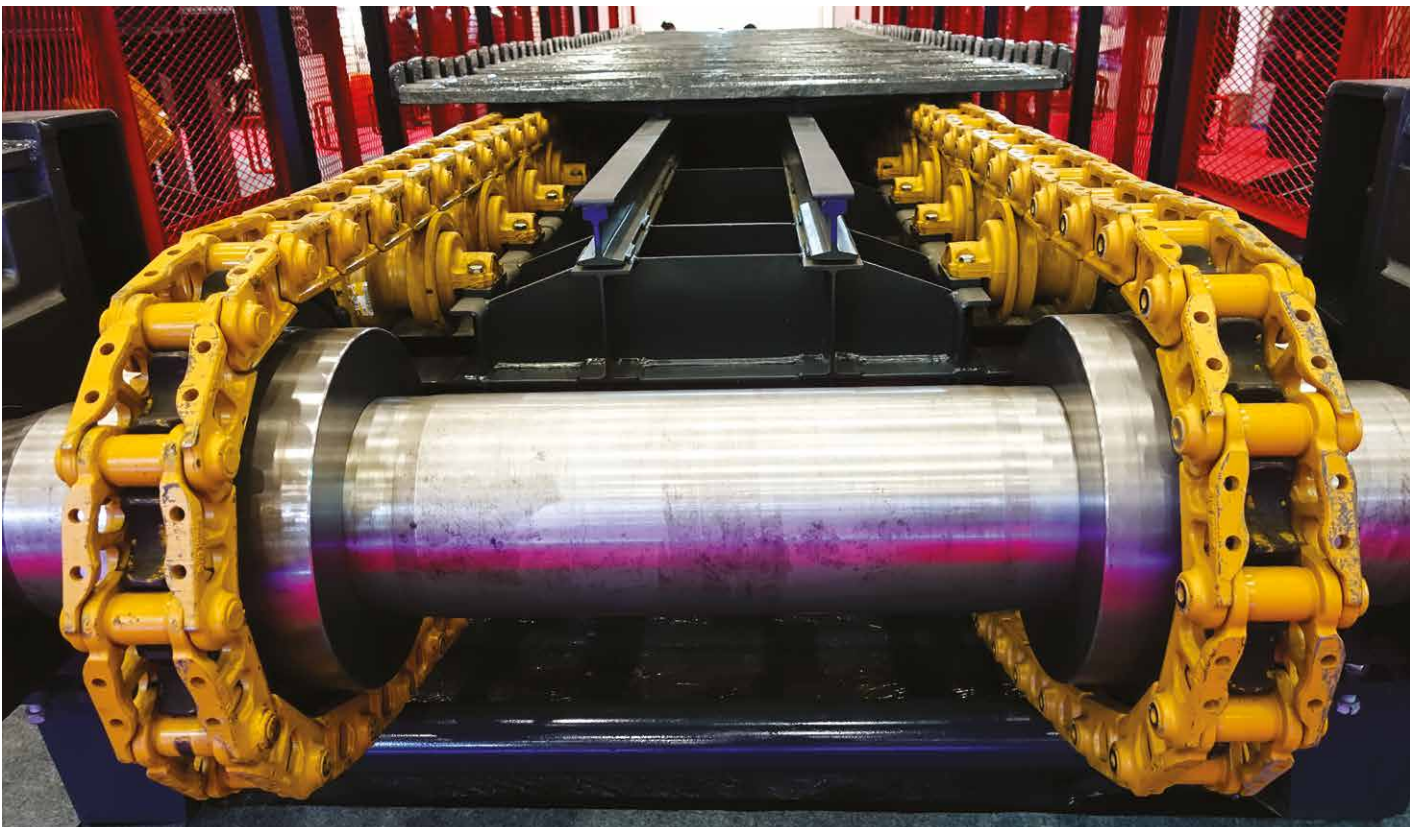

Locking conveyor chain wheels using SIT-LOCK® 4 COMPACT.

In accordance with the SIT S.p.A. policy, for a constant improvement of our products, technical data contained in this catalog may be changed without notice.

SIT pulleys and related products are designed in Italy and manufactured and / or controlled in the group's SIT in the world:  
ITALY: Val Brembilla / GERMANY: Brake / FRANCE: Argenteuil / SPAIN: Barcelona / CHINA: Shanghai / INDIA: Pune  
All the pulleys and components manufactured by SIT are in compliance with the RoHS regulation (RoSH Directive 2011/65/UE) and the REACH Directive (1907/2006).

SIT S.p.A. DOES NOT supply products for applications within the following markets: Aeronautical sector, Nuclear sector, Aerospace sector and Off-shore sector. SIT products are specifically designed for the industrial sector; therefore SIT does not assume any responsibility for the use of its products in the above mentioned sectors, being applications that require different safety factors from those of the industrial use for which they have been designed.



**DRIVE**  
SOLUTIONS

**SIT S.p.A.**  
**Viale A. Volta, 2**  
**20047 Cusago (MI) - Italy**  
**Tel. +39 02 89144 1**  
**Fax +39 02 89144 293**  
**export@sitspa.it**  
**www.sitspa.com**

*Factory*

Via G. Carminati, 15  
24012 Val Brembilla (BG) - Italy

AUTHORIZED DISTRIBUTOR

SIT GERMANIA

**SIT ANTRIEBSELEMENTE GmbH**  
Rieseler Feld 9 (Gewerbegebiet West)  
D - 33034 Brakel  
Tel. +49 52 72 39 28 0  
Fax +49 52 72 39 28 90  
E-mail: info@sit-antriebselemente.de  
Web: www.sit-antriebselemente.de

SIT SWIZZERA

**SIT (Schweiz) AG**  
Lenzbüel 13  
CH - 8370 Sirmach  
Tel. +41 71 969 50 00  
Fax +41 71 969 50 01  
E-mail: info@sit-antriebstechnik.ch  
Web: www.sit-antriebstechnik.ch

SIT SPAGNA

**DINAMICA DRIVE SOLUTIONS S.A.**  
Ctra. N-II, Km 592,6  
E - 08740 S. Andreu De La Barca  
(Barcelona)  
Tel. +34 93 653 35 00  
Fax +34 93 653 35 08  
E-mail: dinamica@dinamica.net  
Web: www.dinamica.net

SIT FRANCIA

**FOGEX SAS**  
215, Rue Henri Barbusse  
F - 95100 Argenteuil  
Tel. +33 1 34 34 46 00  
Fax +33 1 34 34 46 01  
E-mail: info@fogex.com  
Web: www.fogex.com

SIT USA

**SIT ELATECH, INC.**  
11540-A Cordage St  
NC - 28273 Charlotte  
Tel. +1 704 357 8811  
Fax +1 704 357 8866  
E-mail: info@sit-elatech.com  
Web: www.sit-elatech.com

SIT CINA

**SIT ELATECH (SHANGHAI) LTD.**  
Room 804, Building 2, Alley 8666  
Hunan Highway  
Pudong New District  
PRC – 201314 Shanghai  
Tel. +86 021 51082206  
Fax +86 021 64863511  
E-mail: info@sit-shanghai.com  
Web: www.sit-shanghai.com

SIT INDIA

**SIT PTC INDIA PRIVATE LIMITED**  
S. No. 353/A, Gauddara Road,  
A/p. Gauddara, Shriram Nagar,  
Khed-Shivapur, Tal.: - Haveli,  
Dist.: - Pune - 412205  
Tel. +91 9158 5921 11  
E-mail: a.nangre@sitspa.com  
Web: www.sitspa.com